



klindex®

FLOOR TREATMENT SPECIALIST

ENG270319



EN

2019

Klindex was founded by Ercole and Enio Bibiano in 1988. The Bibiano brothers, with over 10 years of experience in the sale of machines for the cleaning industry, perfected and patented their new system for polishing natural stone using the synthetic diamond pads technology. At first it wasn't easy to introduce this new technology, because the customers were reluctant to believe that such innovation could improve upon the tried and proved method geared around the traditional heavy grinding machines. After a few years, however, thanks to the results and testimonials coming in from early customers, scepticism began fading to the point that the KLINDEX SYSTEM is now recognized as arguably "the best system for grinding and polishing all kinds of natural stones." In a remarkably short period of time, contractors and fabricators from all over the world have been having a great deal of success with the Klindex floor care systems. Official recognition of the Bibiano's achievement came in the form of the coveted NOMINATION FOR THE MOST INNOVATIVE PRODUCT AWARD conferred to Klindex at the Amsterdam Inter-Clean 2000 Convention for the mono-brush UNIKA. This nomination has been acknowledged again on 2004 with "IDRAULIKUS". Our company is still working very hard to improve its products, and it continually invests time and money in research and development in order to offer the best machines available to a world-wide customers.

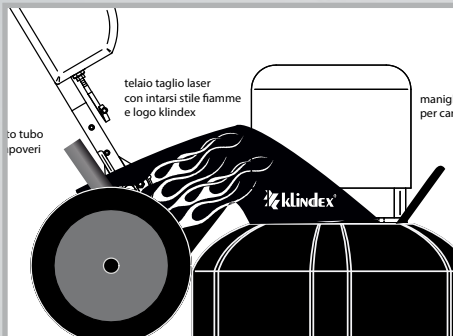
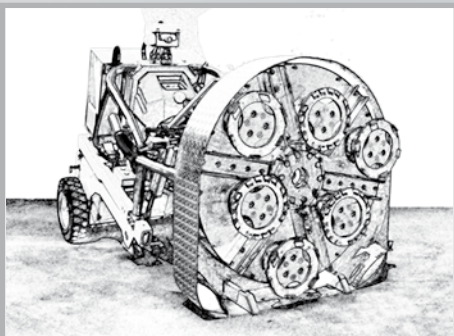
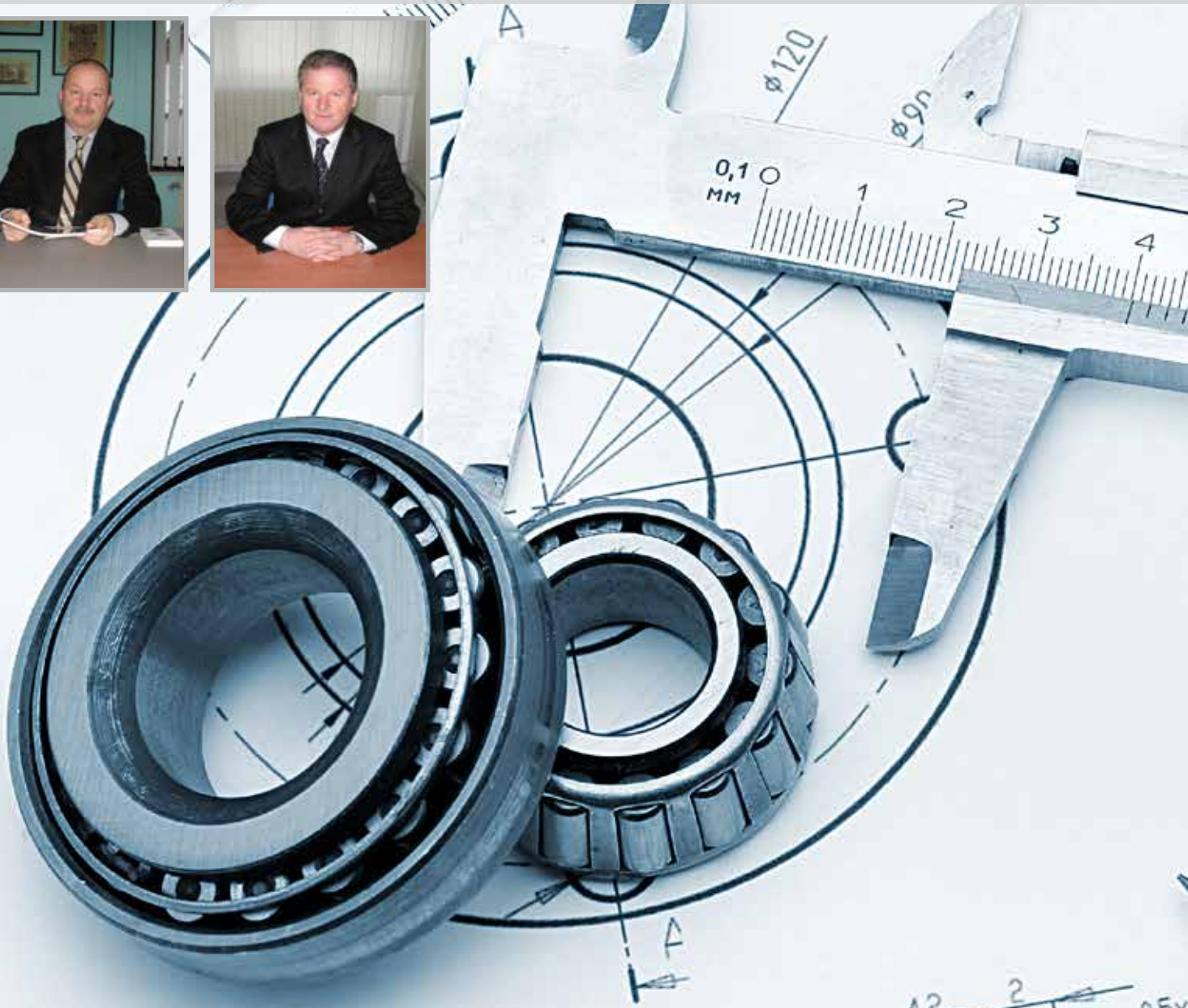

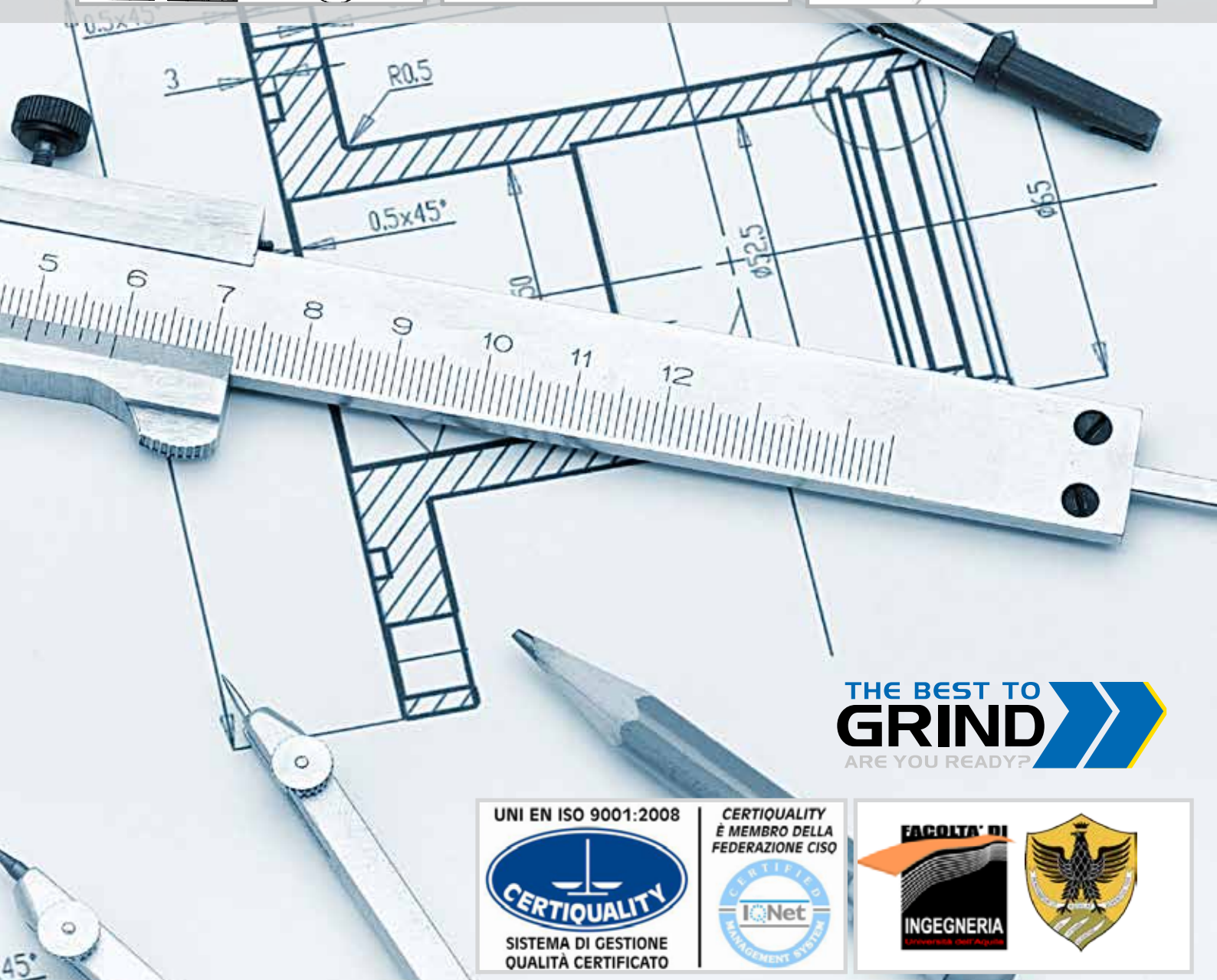
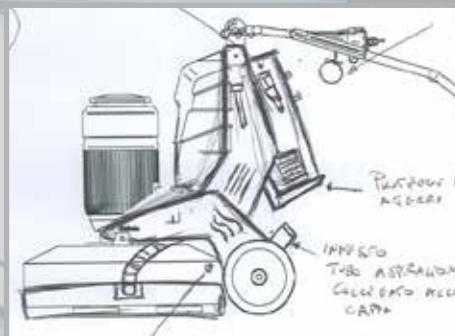
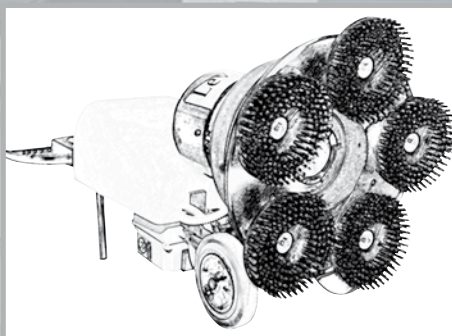
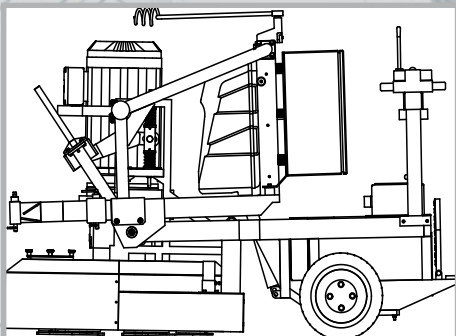

THE BEST TO
GRIND 
ARE YOU READY?

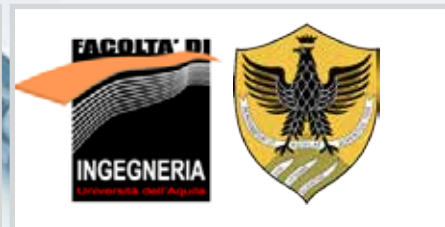

Klindex s.r.l designs and produces machines for cleaning and restoration of all surfaces. Thanks to its competence, KLINDEX assures to its customers efficient and good services. Moreover, thanks to the cooperation between Klindex and its customers, all the market demands are satisfied. All the projects are studied and supported by KLINDEX with up-to-date programs. KLINDEX has already achieved the certification UNI EN ISO 9001: 2000 for "DESIGN, PRODUCTION, SALE OF CLEANING AND GRINDING MACHINES". Klindex is famous for its vivacity in the design and new projects. Klindex regularly collaborate with the University of L'Aquila and with its department of Energy for researches activities. Every year creates new Engineers. Klindex is very sensible to the ecological impact. For this reason, all the researches are finalized to use ecological materials with no noxious residue.



FREE TRAINING COURSE

The evolution of intelligent t



TO LEARN HOW TO GRIND AND POLISH FLOORS

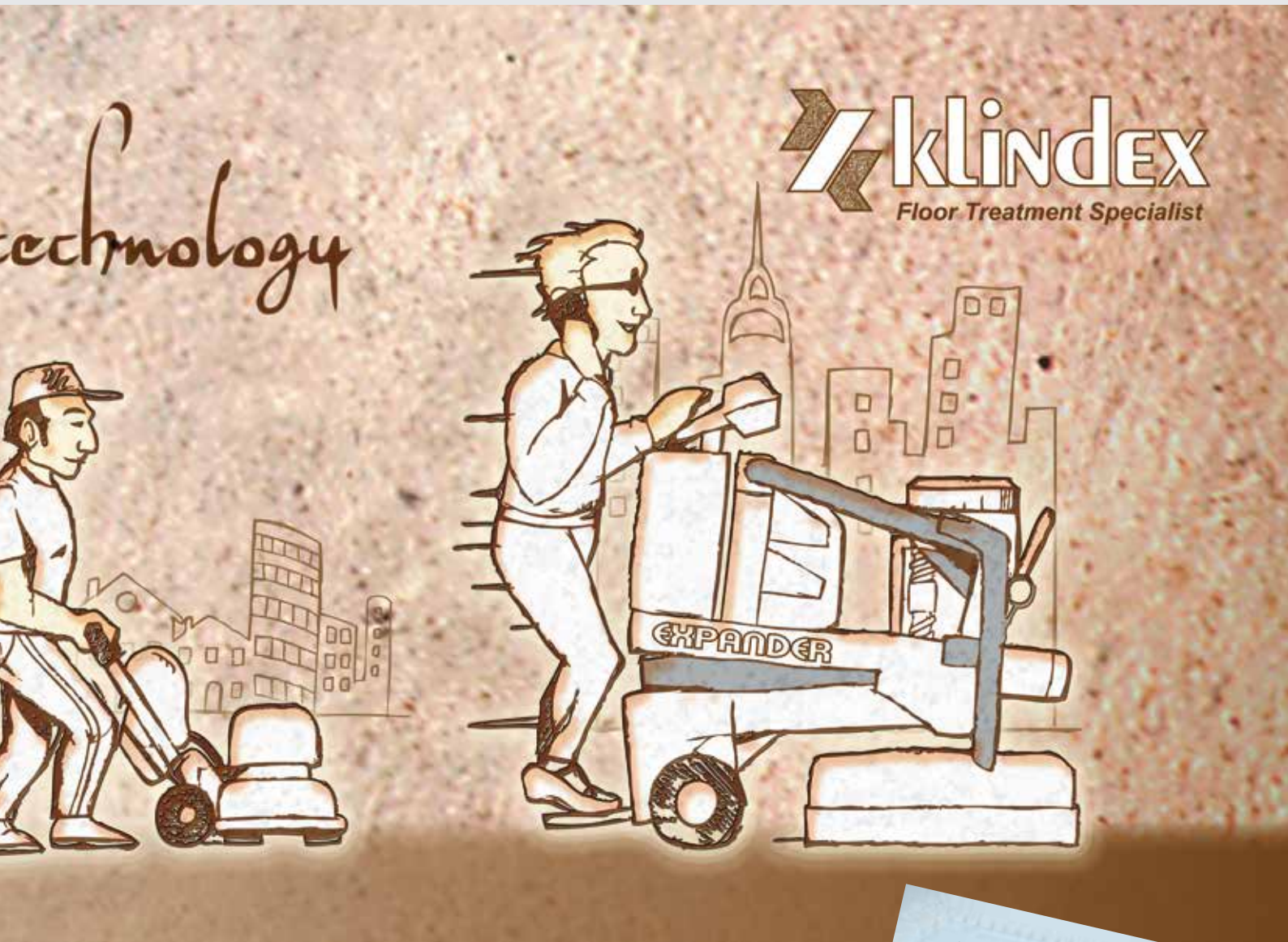

Klindex offers **TWO DAYS OF FREE TRAINING COURSE** to learn how to grind and polish floors such as: marbles, granites, stones and concrete.

KLINDEX SYSTEM is having a lot of success worldwide because it is easier, faster and more economic than any other system available on the market.
If you are interested in learning the latest technology do not hesitate to contact us.
You are welcome to Italy at anytime.
Training courses are held every Thursdays and Fridays.
We only need 2 weeks notice before your coming.

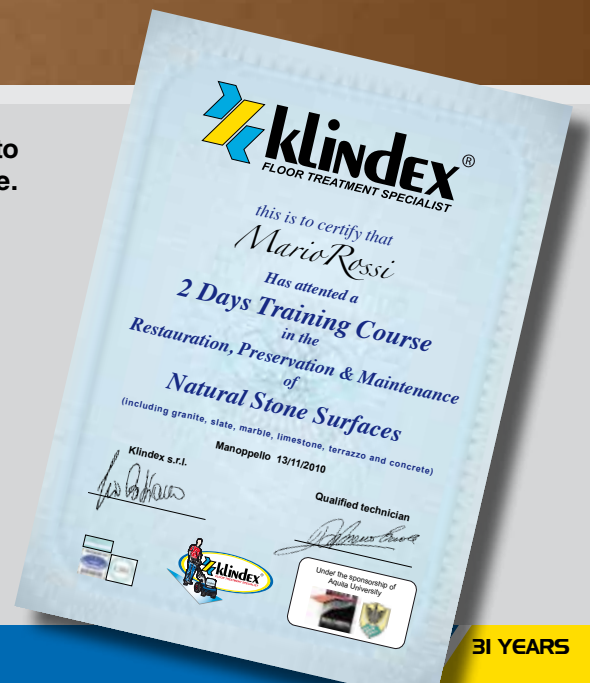

FLOOR GRINDERS

pag. 14



Expander 1000

pag. 16



Expander 999

pag. 18



Expander 950

pag. 20



Expander 850

pag. 22



Expander 850/750Propane

pag. 24

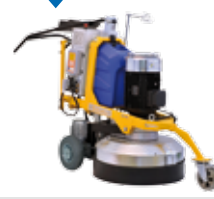

Expander 750

pag. 26

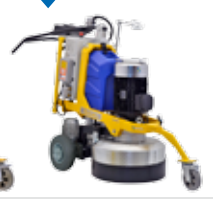

Expander 650

MONOBRUSH

pag. 50



Triple K

pag. 52



Tornado

pag. 53



Hurrikane propane

pag. 54



Hurrikane

pag. 55



Kroma

pag. 56



Futura

SPECIAL MACHINES

pag. 144



Vertika

pag. 148



Waterfire

pag. 152



Ufo

pag. 154



Extrema

pag. 156



Baby

pag. 158



Minipower

pag. 160



MaxiQuadra

SPECIAL MACHINES

pag. 178



Rafter M & Rafter T

VACUUM CLEANERS

pag. 190-191



Supervak 90

pag. 192



Supervak 77

pag. 193



Supervak X3

pag. 194



Supervak 66-67

pag. 195



Supervak 60

pag. 196



Supervak KII

FLOOR GRINDERS

pag. 28



Expander 530 propane

pag. 29



Expander 580-530

pag. 30-31



Levighetor Max

pag. 32-33



Hercules propane

pag. 34-39



Hercules series

pag. 42-45



Levighetor series

pag. 46-47



Rotoklin series

MONOBRUSH

pag. 57



Unika

pag. 58



Rocky

pag. 59-60



Bella

pag. 62



Maxi Orbit

pag. 64



Mini Orbit

SPECIAL MACHINES

pag. 164



Timba

pag. 166



Bella Sander

pag. 168



Kroma Sander

pag. 169



Maxi Orbit Sander

pag. 170



Futura Sander

pag. 171



Unika Sander

pag. 172



Minitimba

VACUUM CLEANERS

pag. 182



Supervak 300

pag. 184



Supervak 250 propane

pag. 185



Supervak 250

pag. 186



Supervak 200

pag. 187



Supervak Oil

pag. 188



Supervak I44-I55-I75

pag. 189



Supervak I30-I40

VACUUM CLEANERS

pag. 197



Supervak I5H

pag. 198



Pre-separators

pag. 202



Drum

pag. 203-204



Junior series

pag. 205



Telecontrol

pag. 206



Aspirolava

pag. 207



Vapor

DIAMOND TOOLS AND FLOOR SOLUTIONS

pag. 66-70



Single Disc Accessories

pag. 71



Floor Pads

pag. 72-79



Supershine & Spongelux

pag. 80



Planetary

DIAMOND TOOLS AND FLOOR SOLUTIONS

pag. 98



Superconcrete

pag. 106



Polished Copter

pag. 108



Elica

pag. 111



SuperClean

pag. 112

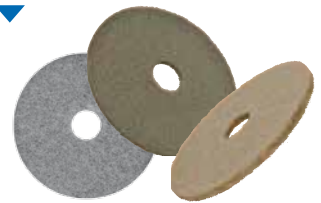

King Conc

DIAMOND TOOLS AND FLOOR SOLUTIONS

pag. 120



Pavelux

pag. 122



Antique Finishing

pag. 124



Trapezoid

pag. 126



Velcro Baked

DIAMOND TOOLS FOR SPECIAL MACHINES

pag. 48



Rotoklin

pag. 145



Vertika

pag. 149



Waterfire

pag. 153



Ufo

pag. 155



Extrema

CHEMICAL PRODUCTS

pag. 209



Polish

pag. 210



Special

pag. 212



Linoleum, Pvc

pag. 213



Terracotta

pag. 214



Mastic

DIAMOND TOOLS AND FLOOR SOLUTIONS

pag. 82-85



Easy Kit

pag. 87



Coating Remove

pag. 90



Floor Preparations

pag. 94



Bush-Hammer

DIAMOND TOOLS AND FLOOR SOLUTIONS

pag. 114



Marble

pag. 116



Terrazzo

pag. 118



Granite & Gres Tiles

DIAMOND TOOLS AND FLOOR SOLUTIONS

pag. 130



Ready Cool

pag. 134



Quick Lock

pag. 138



X-Line

pag. 142



Flash Diamond tools

DIAMOND TOOLS FOR SPECIAL MACHINES

pag. 157



Baby

pag. 159



Minipower

pag. 161



MaxiQuadra

pag. 174



Timba/Kroma/Futura/Unika Sander

MARKETING SUPPORT

pag. 216



Spare Parts

pag. 220



Edward series

pag. 224



Marketing Support

Klindex SLFF "SUPER LASER FLAT FLOOR" Auto Levelling floor with Laser System

GRINDING

SINGLE DISC

TOOLS

SPECIAL

VACUUM

CHEMICALS

MARKETING

START

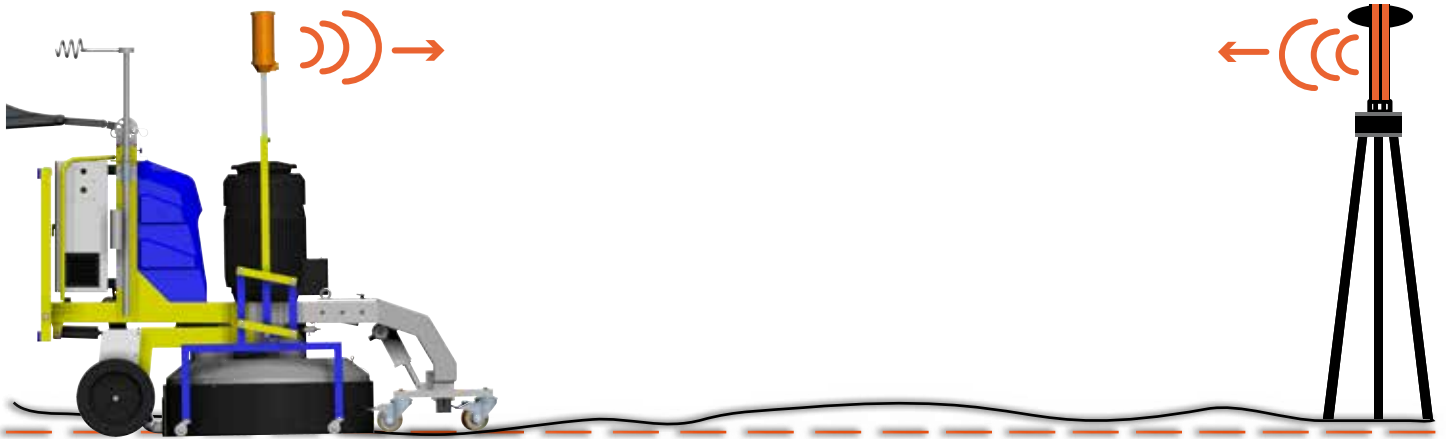

FINISH

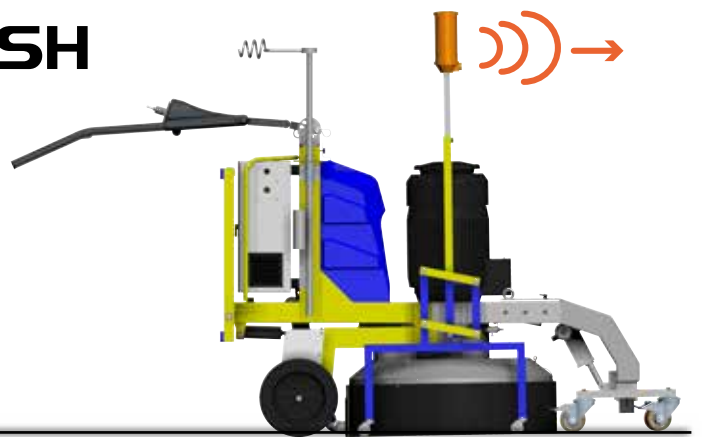

The easiest and most accurate way to achieve a planar surface.

The system Klindex SLFF consists of a rotating laser and a signal receiver mounted on the grinder. The system automatically controls the pressure of the machine when grinding.

"The receiver axially mounted on the planetary improves the accuracy of the planarity."

ADVANTAGES:

- One can level a surface in a very simple and effective way.
- Extraordinary saving of time and energy.
- Environmentally friendly because the floor does not require additional coatings.
- Impressive quality-price ratio.
- Perfect for warehouses with high shelving.



Klindex "SLFF"

New AT (Auto Pilot) Technology

FINALLY THE GRINDING AND POLISHING MACHINE THAT DOES IT ALL ON ITS OWN!

GRINDING

SINGLE DISC

TOOLS

SPECIAL

VACUUM

CHEMICALS

MARKETING



Features:

- Automatic planetary lifting with remote control
- Easy transportation
- Great driving power
- Automatic swinging function
- Automatic reverse
- Automatic grinding of the whole working surface
- Precision edge grinding
- Extreme maneuverability

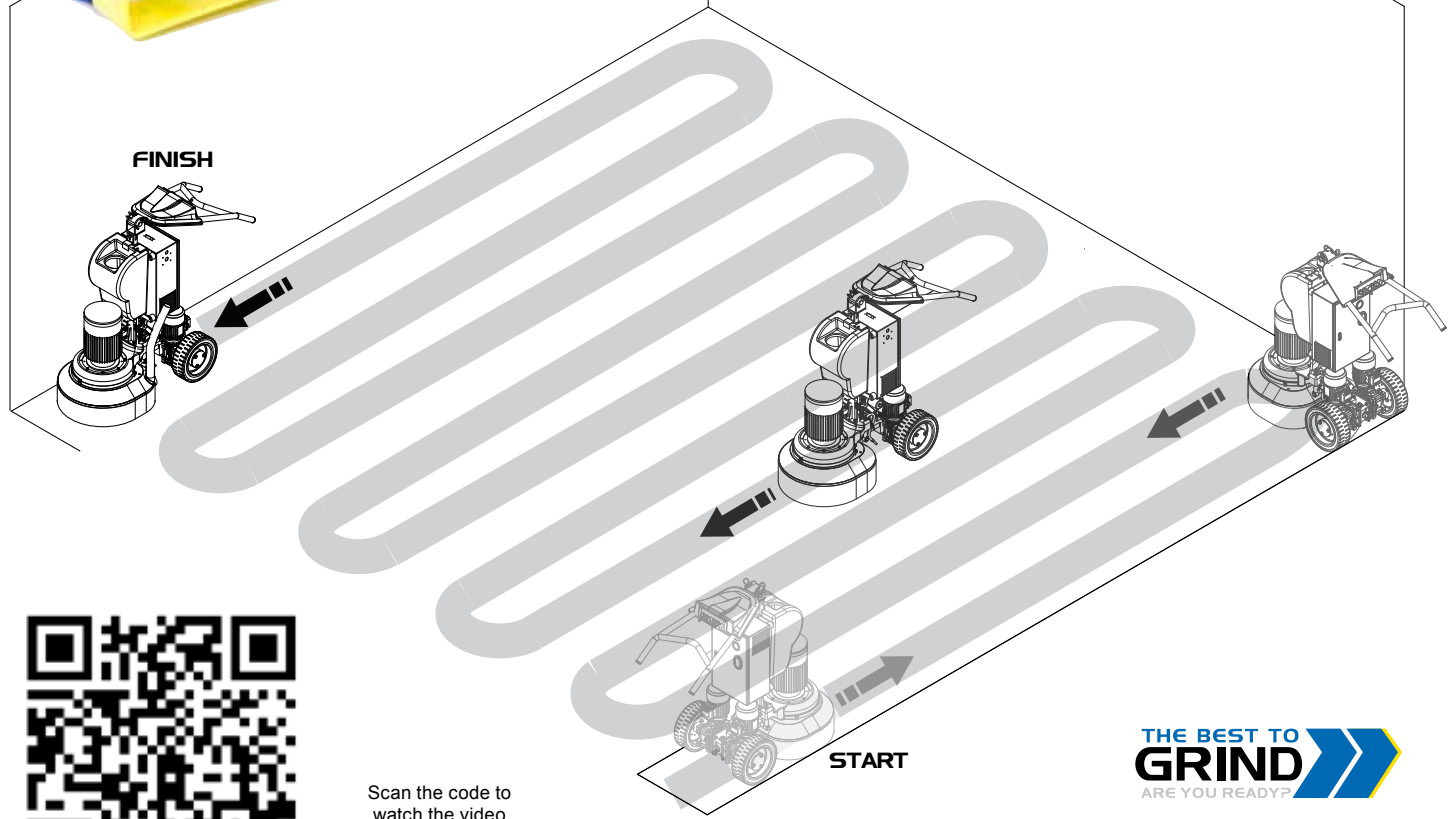

Scan the code to watch the video













ALL IN THE PALM OF YOUR HAND

Klindex has developed a new and exclusive technology of remote automatic control for grinding and polishing machines. With this amazing system called AT (Auto Pilot) Klindex machines can grind on their own the entire area moving forward, turning and coming back, crossing the grinding tracks leaving no untreated parts. Without any interruption, it is also possible to modify all the variables of the machine with a comfortable, handy and intuitive remote control.



Expander series

main features of the different versions.

		SX	RX	AT
	Battery on-board for an easy transportation		✓	✓
	Basic remote control	✓	✓	
	Advanced remote control			✓
	Automatic advancement	✓	✓	✓
	Automatic swinging function	✓	✓	✓
	Automatic reverse			✓
	Automatic overlap			✓
	Automatic grinding of the whole working surface			✓
	Upgrade to AT (auto-pilot) version	✓	✓	
	220V socket		✓	✓

Expander 1000 AT/RX/SX



The biggest floor grinder radio controlled Klindex 6 heads counter-rotating, adjustable work pressure and variable speed.



GRINDING

SINGLE DISC

TOOLS

SPECIAL

VACUUM

CHEMICALS

MARKETING



Self powered transport system



No belt to break



Remote control easy, smart and safe



Auto-Levelling Planetary System



Semi-automatic planetary lifting



Anti-Shock System



Remote-controlled



- Electronic control of the working pressure.

DATA FOR SHIPPING		
Vol. Packaging	Size Packaging	Weight
3,80 m ³	200x160x120 cm	1340 kg

ESTIMATED PRODUCTION	
Superconcrete 7 step	40-45m ² /h
Concrete Grinding 1 step	160-220m ² /h
Terrazzo Polishing 5 step	45-60m ² /h
Resin Removing 1 step	200-300m ² /h
Varnish Removing 1 step	200-300m ² /h
Marble Polishing 5 step	30-50m ² /h
Granite Polishing 7 step	20-30m ² /h

*Production numbers may vary according to surface conditions, diamonds used, equipment operator, etc.

Expander 1000 with the best quality/price relation is the best **fully automatic** 6 headed grinding machines in the world. With the included **remote control** it is possible to adjust working functions such as: • Speed and directions of the machine. • Speed of the planetary. • Planetary turning directions. • Drift control. • Emergency safety stop.

Main features: One button system to rotate the planetary of 90° to allow a fast and easy change of tools. • Strong gear box with thermo-hardened steel gears for a longer life. • Adjustable working pressure from 500 up to 1250 kg. • Adjustable inclination of the Planetary to allow a bigger frontal cutting. • No noise during the work. • Third insertable front wheel for easy transport and to load into the van. • Battery powered for independent tractions when unplugged. • Auto levelling Planetary System. • Powered planetary lifting. **Additional features:** • To prevent working emergencies the machine is engineered to be operated also manually with included special handle and independent manual hydraulic pump.

TECHNICAL DATA												
Model	Motor	Volt	Hertz	Amp	Speed Tools	Working Width	Pressure Work	Tools Size	Water Tank	Dimensions WxHxD cm	Weight	Price
EXPANDER 1000 SX	25 HP	380-480	50/60	35	300-1300 rpm	1000mm	500-1200Kg	6x240mm	46 lt	170x150x105	1313 Kg	n.a.
EXPANDER 1000 RX	25 HP	380-480	50/60	35	300-1300 rpm	1000mm	500-1200Kg	6x240mm	46 lt	170x150x105	1313 Kg	n.a.
EXPANDER 1000 AT	25 HP	380-480	50/60	35	300-1300 rpm	1000mm	500-1200Kg	6x240mm	46 lt	170x150x105	1313 Kg	n.a.



Suitable for heavy-duty use



Front wheel for transport



Adjustable work pressure

Expander 999 AT/RX/SX



Pursuing the top for less



GRINDING

SINGLE DISC

TOOLS

SPECIAL

VACUUM

CHEMICALS

MARKETING



Led lights



No belt to break



Remote control easy, smart and safe



Auto-Levelling Planetary System



Anti-Shock System



Remote-controlled



GRINDING

SINGLE DISC

TOOLS

SPECIAL

VACUUM

CHEMICALS

MARKETING

DATA FOR SHIPPING

Vol. Packaging	Size Packaging	Weight
3,80 m ³	200x160x120 cm	980 kg

ESTIMATED PRODUCTION

Superconcrete 7 step	40-45m ² /h
Concrete Grinding 1 step	160-220m ² /h
Terrazzo Polishing 5 step	45-60m ² /h
Resin Removing 1 step	200-300m ² /h
Varnish Removing 1 step	200-300m ² /h
Marble Polishing 5 step	30-50m ² /h
Granite Polishing 7 step	20-30m ² /h

*Production numbers may vary according to surface conditions, diamonds used, equipment operator, etc.

EXPANDER 999, with the powerful 6-head planetary and a brand new more compact and lightweight frame. The 6 offset rotating heads guarantee perfect flatness of the polished surface and the perfect machine balance.

- Easy to transport thanks to the on board batteries, even on steep ramps.
- The new frame guarantees smaller overall dimensions and less weight for the load on the van.
- Working with radio control guarantees increased productivity for the operator thereby reducing stress and fatigue thanks to the absence of vibrations.
- The automatic shift allows the operator to easily perform all the supporting activities.
- Helical and very quiet gears made of thermo-hardened steel
- Electronically adjustable planetary pressure.
- New version with Autopilot system.

TECHNICAL DATA

Model	Motor	Volt	Hertz	Amp	Speed Tools	Working Width	Tools Size	Water Tank	Dimensions WxHxD cm	Weight	Price
EXPANDER 999 SX	25 HP	380-480	50/60	35	300-1300 rpm	1000mm	6x240mm	46 lt	215x168x105	950 Kg	€ n.a.
EXPANDER 999 RX	25 HP	380-480	50/60	35	300-1300 rpm	1000mm	6x240mm	46 lt	215x168x105	950 Kg	€ n.a.
EXPANDER 999 AT	25 HP	380-480	50/60	35	300-1300 rpm	1000mm	6x240mm	46 lt	215x168x105	950 Kg	€ n.a.



Expander 950 AT/RX/SX



Remote-control planetary grinding machine with variable speed and adjustable working pressure.



Remote-controlled

GRINDING

SINGLE DISC

TOOLS

SPECIAL

VACUUM

CHEMICALS

MARKETING

ESTIMATED PRODUCTION

Superconcrete 7 step	30-35m ² /h
Concrete Grinding 1 step	100-130m ² /h
Terrazzo Polishing 5 step	35-45m ² /h
Resin Removing 1 step	150-180m ² /h
Varnish Removing 1 step	150-180m ² /h
Marble Polishing 5 step	25-35m ² /h
Granite Polishing 7 step	15-20m ² /h

*Production numbers may vary according to surface conditions, diamonds used, equipment operator, etc.

Expander 950: Big grinding machine with remote control designed to work on large area.

Main features: With the included remote control it is possible to control all the working functions such as: • Speed and directions of the machine. • Speed of the planetary. • Planetary turning directions. • Control of grinding head pressure. • Drift control. • Emergency safety stop.

Additional features: • Working width 950 mm with 3 large size 340 mm tools. • Speed of tools ranging from 300 to 1300 rpm. • Automatic adjustment of the working pressure. • Strong gear box with thermo-hardened steel gears for a longer life. • Adjustable inclination of the Planetary to allow a bigger frontal cutting. • No noise during the work. • Third insertable front wheel for easy transport and to load into the van. • Battery powered for independent tractions when unplugged. • Auto levelling Planetary System. • To prevent working emergencies the machine is engineered to be driven manually using the included handle and unlocking traction wheels.

TECHNICAL DATA

Model	Motor	Drive Inverter	Volt	Hertz	Amp	Speed Tools	Working Width	Tools Size	Water Tank	Dimensions WxHxD cm	Weight	Price
EXPANDER 950 SX	25 HP	18,5 kW	380-480	50/60	32	300-1300 rpm	950mm	3x340mm	46 lt	150x150x95	484 Kg	€ n.a.
EXPANDER 950 RX	25 HP	18,5 kW	380-480	50/60	32	300-1300 rpm	950mm	3x340mm	46 lt	150x150x95	484 Kg	€ 41.195,00
EXPANDER 950 AT	25 HP	18,5 kW	380-480	50/60	32	300-1300 rpm	950mm	3x340mm	46 lt	150x150x95	484 Kg	€ 44.695,00

DATA FOR SHIPPING

Vol. Packaging	Size Packaging	Weight
2,75 m ³	160x160x110 cm	510 kg



Adjustable working pressure



Self powered transport system



Tool size 340mm

Expander 950



Planetary floor grinder with variable speed and adjustable working pressure.



Expander 950: Big grinding machine designed to work on large area.
Main features: • Working width 950 mm with 3 large size 340 mm tools. • Speed of tools ranging from 300 to 1300 rpm. • Automatic adjustment of the working pressure. • Strong gear box with thermo-hardened steel gears for a longer life. • Adjustable inclination of the Planetary to allow a bigger frontal cutting. • No noise during the work. • Third insertable front wheel for easy transport and to load into the van. • Auto levelling Planetary System.

ESTIMATED PRODUCTION	
Superconcrete 7 step	30-35m ² /h
Concrete Grinding 1 step	100-130m ² /h
Terrazzo Polishing 5 step	35-45m ² /h
Resin Removing 1 step	150-180m ² /h
Varnish Removing 1 step	150-180m ² /h
Marble Polishing 5 step	25-35m ² /h
Granite Polishing 7 step	15-20m ² /h

* Production numbers may vary according to surface conditions, diamonds used, equipment operator, etc.

TECHNICAL DATA												
Model	Motor	Drive Inverter	Volt	Hertz	Amp	Speed Tools	Working Width	Tools Size	Water Tank	Dimensions WxHxD cm	Weight	Price
EXPANDER 950	25 HP	18,5 kW	380-480	50/60	32	300-1300 rpm	950mm	3x340mm	46 l	150x150x95	421 kg	€ 28.495,00



Full metal gear box



Third front wheel

DATA FOR SHIPPING		
Vol. Packaging	Size Packaging	Weight
2,75 m ³	160x160x110 cm	460 kg



Intuitive control panel

Expander 850 AT/RX/SX



GRINDING

SINGLE DISC

TOOLS

SPECIAL

VACUUM

CHEMICALS

MARKETING

Remote-control planetary grinding machine with variable speed and adjustable working pressure.



Remote-controlled

Remote controlled grinding and polishing machine for medium-big sized surfaces.

Main features: With the included remote control it is possible to control all the working functions such as: • Speed and directions of the machine. • Speed of the planetary. • Planetary turning directions. • Control of grinding head pressure. • Drift control. • Emergency safety stop.

Additional features: • Working width 850 mm with 3 large size 240 mm tools. • Speed of tools ranging from 300 to 1300 rpm. • Automatic adjustment of the working pressure. • Strong gear box with thermo-hardened steel gears for a longer life. • Adjustable inclination of the Planetary to allow a bigger frontal cutting. • No noise during the work. • Third insertable front wheel for easy transport and to load into the van. • Battery powered for independent tractions when unplugged. • Auto levelling Planetary System. • To prevent working emergencies the machine is engineered to be driven manually using the included handle and unlocking traction wheels.

ESTIMATED PRODUCTION

Superconcrete 7 step	25-30m ² /h
Concrete Grinding 1 step	100-130m ² /h
Terrazzo Polishing 5 step	30-40m ² /h
Resin Removing 1 step	100-150m ² /h
Varnish Removing 1 step	100-150m ² /h
Marble Polishing 5 step	20-30m ² /h
Granite Polishing 7 step	10-15m ² /h

*Production numbers may vary according to surface conditions, diamonds used, equipment operator, etc.

TECHNICAL DATA

Model	Motor	Drive Inverter	Volt	Hertz	Amp	Speed Tools	Working Width	Tools Size	Water Tank	Dimensions WxHxD cm	Weight	Price
EXPANDER 850 SX	25 HP	18,5 kW	380-480	50/60	32	300-1300 rpm	850mm	3x240mm	46 lt	150x150x95	484 Kg	€ 36.500,00
EXPANDER 850 RX	25 HP	18,5 kW	380-480	50/60	32	300-1300 rpm	850mm	3x240mm	46 lt	150x150x95	484 Kg	€ 39.650,00
EXPANDER 850 AT	25 HP	18,5 kW	380-480	50/60	32	300-1300 rpm	850mm	3x240mm	46 lt	150x150x95	484 Kg	€ 42.650,00

DATA FOR SHIPPING

Vol. Packaging	Size Packaging	Weight
2,75 m ³	160x160x110 cm	510 kg



Remote-controlled



Self powered transport system



Powerful traction motors

Expander 850



Planetary floor grinder with variable speed and adjustable working pressure.



Expander 850: Floor grinding and polishing machine for medium and big sized surfaces available into two versions of 20 and 25 HP.
Main features: • Working width 850 mm with 3 large size 240 mm tools. • Speed of tools ranging from 300 to 1300 rpm. • Automatic adjustment of the working pressure. • Strong gear box with thermo-hardened steel gears for a longer life. • Adjustable inclination of the Planetary to allow a bigger frontal cutting. • No noise during the work. • Third insertable front wheel for easy transport and to load into the van. • Auto levelling Planetary System.

ESTIMATED PRODUCTION	
Superconcrete 7 step	25-30m ² /h
Concrete Grinding 1 step	100-130m ² /h
Terrazzo Polishing 5 step	30-40m ² /h
Resin Removing 1 step	100-150m ² /h
Varnish Removing 1 step	100-150m ² /h
Marble Polishing 5 step	20-30m ² /h
Granite Polishing 7 step	10-15m ² /h

*Production numbers may vary according to surface conditions, diamonds used, equipment operator, etc.

TECHNICAL DATA												
Model	Motor	Drive Inverter	Volt	Hertz	Amp	Speed Tools	Working Width	Tools Size	Water Tank	Dimensions WxHxD cm	Weight	Price
EXPANDER 850	20 HP	15 kW	380-480	50/60	32	300-1300 rpm	850mm	3x240mm	46 lt	150x150x95	441 Kg	€ 25.995,00
EXPANDER 850	25 HP	18,5 kW	380-480	50/60	32	300-1300 rpm	850mm	3x240mm	46 lt	150x150x95	451 Kg	€ 26.650,00



Full metal gear box



Adjustable and removable handle

DATA FOR SHIPPING		
Vol. Packaging	Size Packaging	Weight
1,40m ³	160x160x110 cm	455 kg



Intuitive control panel

Expander 850 Propane



GRINDING

SINGLE DISC

TOOLS

SPECIAL

VACUUM

CHEMICALS

MARKETING

Propane floor grinder with variable speed and adjustable working pressure.



▶ Expander 850 propane with 850 mm working section is the most versatile and selling machine among the Expander series.

Main advantages

- No performance drop and loss of time caused by the power grid.
- Free from the hassle and costs of extension cords in the yard.
- No need of generator.
- Accurate and reliable adjustable planetary speed.
- Low operating vibrations.
- Accommodation.
- Light and easy to maneuver.
- Ideal for both indoor and outdoor applications.
- Dry or wet grinding.
- Standard 46 liters water tank 46 liters.
- Tempered steel gear transmission.

ESTIMATED PRODUCTION

Superconcrete 7 step	30-35m ² /h
Concrete Grinding 1 step	110-140m ² /h
Terrazzo Polishing 5 step	35-40 m ² /h
Resin Removing 1 step	110-160m ² /h
Varnish Removing 1 step	110-160m ² /h

*Production numbers may vary according to surface conditions, diamonds used, equipment operator, etc.

Recommended batteries: battery 12V 550 ACC Class.

TECHNICAL DATA

Model	Motor	Power	Propano tank	Speed Tools	Working Width	Tools Size	Water Tank	Dimensions WxHxD cm	Weight	Price
EXPANDER 850 Propano	Kawasaki FX921V	21,6kW	20lbs/9kg	500-900	800mm	3x240mm	46 lt	150x150x95	560 Kg	€ 28.950,00

DATA FOR SHIPPING

Vol. Packaging	Size Packaging	Weight
2,75m ³	160x160x110 cm	575 Kg



Adjustable working pressure



Powerful motor

Expander 750 Propane



Propane floor grinder with variable speed and adjustable working pressure.



Expander 750 propane with 8750 mm working section is the most versatile and selling machine among the Expander series.

Main advantages

- No performance drop and loss of time caused by the power grid.
- Free from the hassle and costs of extension cords in the yard.
- No need of generator.
- Accurate and reliable adjustable planetary speed.
- Low operating vibrations.
- Accommodation.
- Light and easy to maneuver.
- Ideal for both indoor and outdoor applications.
- Dry or wet grinding.
- Standard 46 liters water tank 46 liters.
- Tempered steel gear transmission.

Recommended batteries: battery 12V 550 ACC Class.

ESTIMATED PRODUCTION

Superconcrete 7 step	30-35m ² /h
Concrete Grinding 1 step	110-140m ² /h
Terrazzo Polishing 5 step	30-35m ² /h
Resin Removing 1 step	110-160m ² /h
Varnish Removing 1 step	110-160m ² /h

*Production numbers may vary according to surface conditions, diamonds used, equipment operator, etc.

TECHNICAL DATA

Model	Motor	Power	Propano tank	Speed Tools	Working Width	Tools Size	Water Tank	Dimensions WxHxD cm	Weight	Price
EXPANDER 750 Propano	Kawasaki FX850V	19,9kW	20lbs/9kg	500-900	750mm	3x240mm	46 lt	145x145x80	542 Kg	€ 28.150,00

DATA FOR SHIPPING

Vol. Packaging	Size Packaging	Weight
1,40m ³	160x160x110 cm	570 Kg



Adjustable working pressure



Powerful motor

Expander 750 AT/RX/SX



Remote-controlled planetary floor grinder with variable speed and adjustable working pressure.



Remote-controlled

GRINDING
SINGLE DISC
TOOLS
SPECIAL
VACUUM
CHEMICALS
MARKETING

Expander 750: Remote controlled grinding and polishing machine for medium and big sized surfaces.

Main features: With the included remote control it is possible to control all the working functions such as: • Speed and directions of the machine. • Speed of the planetary. • Planetary turning directions. • Control of grinding head pressure. • Drift control. • Emergency safety stop. **Additional features:** • Working width 750 mm with 3 large size 240 mm tools. • Speed of tools ranging from 300 to 1300 rpm. • Automatic adjustment of the working pressure. • Strong gear box with thermo-hardened steel gears for a longer life. • Adjustable inclination of the Planetary to allow a bigger frontal cutting. • No noise during the work. • Third insertable front wheel for easy transport and to load into the van. • Battery powered for independent tractions when unplugged. • Auto levelling Planetary System. • To prevent working emergencies the machine is engineered to be driven manually using the included handle and unlocking traction wheels.

ESTIMATED PRODUCTION

Superconcrete 7 step	25-30m ² /h
Concrete Grinding 1 step	100-130m ² /h
Terrazzo Polishing 5 step	30-40m ² /h
Resin Removing 1 step	100-150m ² /h
Varnish Removing 1 step	100-150m ² /h
Marble Polishing 5 step	20-30m ² /h
Granite Polishing 7 step	9-12m ² /h

*Production numbers may vary according to surface conditions, diamonds used, equipment operator, etc.

TECHNICAL DATA

Model	Motor	Drive Inverter	Volt	Hertz	Amp	Speed Tools	Working Width	Tools Size	Water Tank	Dimensions WxHxD cm	Weight	Price
EXPANDER 750 SX	20 HP	15 kW	380-480	50/60	25	300-1300 rpm	750mm	3x240mm	46 lt	145x145x80	423 Kg	€ 33.800,00
EXPANDER 750 RX	20 HP	15 kW	380-480	50/60	25	300-1300 rpm	750mm	3x240mm	46 lt	145x145x80	423 Kg	€ 36.995,00
EXPANDER 750 AT	20 HP	15 kW	380-480	50/60	25	300-1300 rpm	750mm	3x240mm	46 lt	145x145x80	423 Kg	€ 39.995,00

DATA FOR SHIPPING

Vol. Packaging	Size Packaging	Weight
1,80 m ³	150x145x85 cm	457 kg



Powerful traction motors



Remote-controlled



Full metal gear box

Expander 750



Planetary floor grinder with variable speed and adjustable working pressure.



Expander 750 with 750 mm working section is the most versatile and selling machine among the Expander series. It is available into two versions of 15 and 20 HP.

- Main features:**
- Working width 750 mm with 3 large size 240 mm tools.
 - Speed of tools ranging from 300 to 1300 rpm.
 - Automatic adjustment of the working pressure.
 - Strong gear box with thermo-hardened steel gears for a longer life.
 - Adjustable inclination of the Planetary to allow a bigger frontal cutting.
 - No noise during the work.
 - Third insertable front wheel for easy transport and to load into the van.
 - Auto levelling Planetary System.

ESTIMATED PRODUCTION	
Superconcrete 7 step	25-30m ² /h
Concrete Grinding 1 step	100-130m ² /h
Terrazzo Polishing 5 step	30-40m ² /h
Resin Removing 1 step	100-150m ² /h
Varnish Removing 1 step	100-150m ² /h
Marble Polishing 5 step	20-30m ² /h
Granite Polishing 7 step	9-12m ² /h

* Production numbers may vary according to surface conditions, diamonds used, equipment operator, etc.

TECHNICAL DATA

Model	Motor	Drive Inverter	Volt	Hertz	Amp	Speed Tools	Working Width	Tools Size	Water Tank	Dimensions WxHxD cm	Weight	Price
EXPANDER 750	20 HP	15 kW	380-480	50/60	25	300-1300 rpm	750mm	3x240mm	46 l	145x145x80	360 kg	€ 24.495,00



Full metal gear box



Adjustable and removable handle

DATA FOR SHIPPING		
Vol. Packaging	Size Packaging	Weight
1,80 m ³	150x145x85 cm	394 kg



Intuitive control panel

Expander 650 AT/RX/SX



Remote-controlled planetary floor grinder with variable speed and adjustable working pressure.



Remote-controlled

GRINDING

SINGLE DISC

TOOLS

SPECIAL

VACUUM

CHEMICALS

MARKETING

Expander 650: Remote controlled grinding and polishing machine for medium sized surfaces available into two versions of 10 and 15 HP.

Main features: With the included remote control it is possible to control all the working functions such as: • Speed and directions of the machine. • Speed of the planetary. • Planetary turning directions. • Control of grinding head pressure. • Drift control. • Emergency safety stop. **Additional features:** • Working width 650 mm with 3 large size 240 mm tools. • Speed of tools ranging from 300 to 1300 rpm. • Automatic adjustment of the working pressure. • Strong gear box with thermo-hardened steel gears for a longer life. • Adjustable inclination of the Planetary to allow a bigger frontal cutting. • No noise during the work. • Third insertable front wheel for easy transport and to load into the van. • Battery powered for independent tractions when unplugged. • Auto levelling Planetary System. • To prevent working emergencies the machine is engineered to be driven manually using the included handle and unlocking traction wheels.

ESTIMATED PRODUCTION

Superconcrete 7 step	20-25m ² /h
Concrete Grinding 1 step	50-100m ² /h
Terrazzo Polishing 5 step	20-30m ² /h
Resin Removing 1 step	80-120m ² /h
Varnish Removing 1 step	80-120m ² /h
Marble Polishing 5 step	12-25m ² /h
Granite Polishing 7 step	8-10m ² /h

*Production numbers may vary according to surface conditions, diamonds used, equipment operator, etc.

TECHNICAL DATA

Model	Motor	Drive Inverter	Volt	Hertz	Amp	Speed Tools	Working Width	Tools Size	Water Tank	Dimensions WxHxD cm	Weight	Price
EXPANDER 650RX	10 HP	11 kW	380-480	50/60	25	300-1300 rpm	650mm	3x240mm	46 lt	140x145x68	320 Kg	€ 27.975,00
EXPANDER 650RX	15 HP	11 kW	380-480	50/60	25	300-1300 rpm	650mm	3x240mm	46 lt	140x145x68	370 Kg	€ 30.950,00
EXPANDER 650AT	15 HP	11 kW	380-480	50/60	25	300-1300 rpm	650mm	3x240mm	46 lt	140x145x68	370 Kg	€ 34.495,00

DATA FOR SHIPPING

Vol. Packaging	Size Packaging	Weight
1,80 m ³	150x145x85 cm	385 kg



Adjustable working pressure



240mm tool size



Full metal gear box

Expander 650



Planetary floor grinder with variable speed and adjustable working pressure.



Expander 650 with 650 mm working section for medium sized surfaces. It is available into two versions of 10 and 15 HP.

Main features:

- Working width 650 mm with 3 large size 240 mm tools.
- Speed of tools ranging from 300 to 1300 rpm.
- Automatic adjustment of the working pressure.
- Strong gear box with thermo-hardened steel gears for a longer life.
- Adjustable inclination of the Planetary to allow a bigger frontal cutting.
- No noise during the work.
- Third insertable front wheel for easy transport and to load into the van.
- Auto levelling Planetary System.

ESTIMATED PRODUCTION

Superconcrete 7 step	20-25m ² /h
Concrete Grinding 1 step	50-100m ² /h
Terrazzo Polishing 5 step	20-30m ² /h
Resin Removing 1 step	80-120m ² /h
Varnish Removing 1 step	80-120m ² /h
Marble Polishing 5 step	12-25m ² /h
Granite Polishing 7 step	8-10m ² /h

* Production numbers may vary according to surface conditions, diamonds used, equipment operator, etc.

TECHNICAL DATA

Model	Motor	Drive Inverter	Volt	Hertz	Amp	Speed Tools	Working Width	Tools Size	Water Tank	Dimensions WxHxD cm	Weight	Price
EXPANDER 650	10 HP	11 kW	380-480	50/60	25	300-1300 rpm	650mm	3x240mm	46 l	140x145x68	320 kg	€ 19.995,00
EXPANDER 650	15 HP	11 kW	380-480	50/60	25	300-1300 rpm	650mm	3x240mm	46 l	140x145x68	330 kg	€ 20.995,00



Full metal gear box



Adjustable and removable handle

DATA FOR SHIPPING

Vol. Packaging	Size Packaging	Weight
1,80 m ³	150x145x85 cm	345 kg



Intuitive control panel

Expander 530 Propane



Propane floor grinder
with patented MONO-ROTATING planetary.



▶ Klindex propane powered grinding and polishing machine with patented geared mono-rotating planetary system. Expander 530 Propane combines performance and reliability of Klindex grinding and polishing machines with the flexibility of propane motor. Propane Expander 530 allows independence from generators or power lines. This robust grinder combines hits weight with a working section of 530mm, providing high productivity rates and constant performances. **Main advantages:** • No performance drop and loss of time caused by the power grid. • Very aggressive tanks to the mono-rotating planetary. • Free from the hassle and costs of extension cords in the yard. • No need of generator. • Accurate and reliable adjustable planetary speed. • Low operating vibrations. • Light and easy to maneuver. • Ideal for both indoor and outdoor applications. • Dry or wet grinding. • Standard water tank 46 liters. • Tempered steel gear transmission.

Recommended batteries: battery 12V 550 ACC Class.

ESTIMATED PRODUCTION

Superconcrete 7 step	12-17m ² /h
Concrete Grinding 1 step	50-90m ² /h
Terrazzo Polishing 5 step	12-17m ² /h
Resin Removing 1 step	50-70m ² /h
Varnish Removing 1 step	50-70m ² /h

*Production numbers may vary according to surface conditions, diamonds used, equipment operator, etc.

TECHNICAL DATA

Model	Motor	Power	Propane tank	Speed tools	Working width	Tools Size	Water tank	Dimensions WxHxD cm	Weight	Price
EXPANDER 530 PROPANE	Kawasaki FS603V	12,7kW	9Kg/20lbs	500-1000rpm	530mm	3x240mm	46 l	120x125x60 cm	255 kg	€ n.a.

DATA FOR SHIPPING

Vol. Packaging	Size Packaging	Weight
0,73 m ³	120x80x75 cm	275 Kg

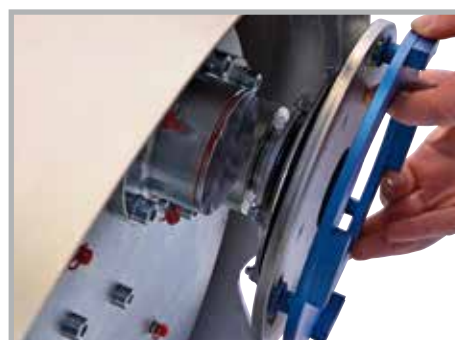

240mm Q.A. diamond tools



Intuitive control panel

GRINDING

SINGLE DISC

TOOLS

SPECIAL

VACUUM

CHEMICALS

MARKETING

Expander 530-580



Floor grinder with planetary counter-rotating and variable speed.

ESTIMATED PRODUCTION		
	530	580
Superconcrete 7 step	10-12m ² /h	10-15m ² /h
Concrete Grinding 1 step	40-70m ² /h	40-80m ² /h
Terrazzo Polishing 5 step	9-12m ² /h	9-15m ² /h
Resin Removing 1 step	40-70m ² /h	40-80m ² /h
Varnish Removing 1 step	40-70m ² /h	40-80m ² /h
Marble Polishing 5 step	7-10m ² /h	7-12m ² /h
Granite Polishing 7 step	5-7m ² /h	5-7m ² /h

*Production numbers may vary according to surface conditions, diamonds used, equipment operator, etc.

Expander with 580 mm and 530 mm working section for medium sized surfaces.

- Main features:**
- Working width 580 with 3 large size 240 mm tools or 530 with 3 large size 200 mm tools
 - Speed of tools ranging from 300 to 1300 rpm.
 - Strong gear box with thermo-hardened steel gears for a longer life.
 - No noise during the work.
 - Auto levelling Planetary System.

TECHNICAL DATA											
Model	Motor	Drive Inverter	Volt	Hertz	Speed Tools	Working Width	Tools Size	Water Tank	Dimensions WxHxD cm	Weight	Price
EXPANDER 530	2900 Watt Max	--	220-240	50/60	900 rpm	530mm	3x200mm	18 l	118x125x57	135 kg	€ 7.995,00
EXPANDER 530VS	3000 Watt Max	--	220-240	50/60	300-1300 rpm	530mm	3x200mm	18 l	118x125x57	145 kg	€ 9.295,00
EXPANDER 530 T4	4 HP	--	380	50/60	900 rpm	530mm	3x200mm	18 l	118x125x57	135 kg	€ 7.995,00
EXPANDER 530VS T4	4 HP	--	380	50/60	300-1300 rpm	530mm	3x200mm	18 l	118x125x57	145 kg	€ 9.450,00
EXPANDER 530VS T5	5,5 HP	--	380	50/60	300-1300 rpm	530mm	3x200mm	18 l	118x125x57	145 kg	€ 9.795,00
EXPANDER 580 T5	5,5 HP	5 kW	380-480	50/60	300-1300 rpm	580mm	3x240mm	18 l	118x125x63	155 kg	€ 9.995,00
EXPANDER 580 T7	7 HP	7,5 kW	380-480	50/60	300-1300 rpm	580mm	3x240mm	18 l	118x125x63	165 kg	€ 10.950,00



Expander 580



Easy to disassembly

DATA FOR SHIPPING			
	Vol. Packaging	Size Packaging	Weight
530	1,23 m ³	120x80x128 cm	222 Kg
580	1,80 m ³	150x145x85 cm	160 Kg



Intuitive control panel

Levighetor Max vs



GRINDING

SINGLE DISC

TOOLS

SPECIAL

VACUUM

CHEMICALS

MARKETING

Floor Grinder with patented **MONO-ROTATING planetary**, adjustable working pressure and variable speed.



▶ **LEVIGHETOR MAX SPEED CONTROL** is the most performing machine of this segment. Thanks to its patented mono-rotating planetary system, no other machine can compete in terms of productivity for grinding and polishing floors. Ideal for grinding and polishing marble, terrazzo, granite and concrete, floor preparation, bush Hammering, old glues and resins removal, and Superconcrete effect.

Main features: • Working width 530 mm with 3 large size 240 mm tools. • Speed of tools ranging from 300 to 1300 rpm. • Automatic adjustment of the working pressure. • Strong gear box with thermo-hardened steel gears for a longer life. • Adjustable inclination of the Planetary to allow a bigger frontal cutting. • No noise during the work. • Third insertable front wheel for easy transport and to load into the van (optional). • Additional extra weights (optional).

ESTIMATED PRODUCTION

Superconcrete 7 step	10-15m ² /h
Concrete Grinding 1 step	40-80m ² /h
Terrazzo Polishing 5 step	9-15m ² /h
Resin Removing 1 step	40-60m ² /h
Varnish Removing 1 step	40-60m ² /h
Marble Polishing 5 step	10-15m ² /h
Granite Polishing 7 step	6-10m ² /h

*Production numbers may vary according to surface conditions, diamonds used, equipment operator, etc.

TECHNICAL DATA

Model	Motor	Drive Inverter	Volt	Hertz	Amp	Speed Tools	Working Width	Tools Size	Water Tank	Dimensions WxHxD cm	Weight	Price
LEVIGHETOR MAX VS	7 HP	7,5 kW	380-480	50/60	16	300-1300 rpm	530mm	3x240mm	18 l	95x130x56	160 kg	€ 9.995,00
LEVIGHETOR MAX VS USA	7,5 Hp	11 kW	220 -1/3phase	50/60	30/20	300-1300 rpm	530mm	3x240mm	18 l	95x130x56	160 kg	€ 9.995,00

DATA FOR SHIPPING

Vol. Packaging	Size Packaging	Weight
0,98 m ³	120x60x136 cm	194 Kg



Adjustable working pressure

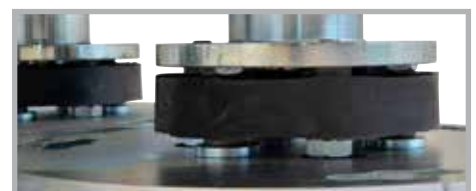

Anti-shok System

Levighetor Max



Floor Grinder with patented **MONO-ROTATING planetary.**



▶ LEVIGHETOR MAX is a high performance and reliable grinding and polishing machine. Perfect not only for polishing large surfaces of marble, terrazzo, granite and concrete, but also for the preparation of industrial floors, for bush hammering, for grinding, for the removal of old glues and resins and for concrete polishing with Super concrete system. Compact and easy to use also in narrow spaces. Thanks to the mono-rotating planetary with steel gears productivity increases by 2-3 times compared with a standard belt driven grinder.

- Main features:**
- Working width 530 mm with 3 large size 240 mm tools.
 - Strong gear box with thermo-hardened steel gears for a longer life.
 - No noise during the work.
 - Third insertable front wheel for easy transport and to load into the van (optional).
 - Additional extra weights (optional).

ESTIMATED PRODUCTION	
Superconcrete 7 step	8-12m ² /h
Concrete Grinding 1 step	40-60m ² /h
Terrazzo Polishing 5 step	10-15m ² /h
Resin Removing 1 step	40-60m ² /h
Varnish Removing 1 step	40-60m ² /h
Marble Polishing 5 step	10-15m ² /h
Granite Polishing 7 step	5-8m ² /h

* Production numbers may vary according to surface conditions, diamonds used, equipment operator, etc.

TECHNICAL DATA												
Model	Motor	Drive Inverter	Volt	Hertz	Amp	Speed Tools	Working Width	Tools Size	Water Tank	Dimensions WxHxD cm	Weight	Price
LEVIGHETOR MAX	7 HP	5,5 kW	380-480	50/60	16	800 rpm	530mm	3x240mm	18 l	95x130x56	152 kg	€ 7.495,00



DATA FOR SHIPPING		
Vol. Packaging	Size Packaging	Weight
1,25 m ³	120x130x80 cm	165 kg



Full metal gear box

Hercules 800 Propane



GRINDING
SINGLE DISC
TOOLS
SPECIAL
VACUUM
CHEMICALS
MARKETING

Propane floor grinder with 4 HEADS
"DCS System" and variable speed.



Full metal gear box

Floor grinder with "DCS System" and variable speed.
Unique propane powered grinding and polishing machine with geared planetary and 4 headed DCS system. DCS system allows short time in surface preparation, even in the most severe environments. With its DCS system Hercules 800 Propane is considered as the most efficient surface preparation grinding machine in the market. Hercules 800 Propane combines performance and reliability of Klindex grinding and polishing machines with the flexibility of propane motor. Propane Hercules 800 allows independence from generators or power lines. This robust grinder combines hits weight with a working section of 800mm, providing high productivity rates and constant performances. **Main advantages:** • No performance drop and loss of time caused by the power grid. • Exclusive DCS system. • Free from the hassle and costs of extension cords in the yard. • No need of generator. • Accurate and reliable adjustable planetary speed. • Low operating vibrations. • Accommodation. • Light and easy to maneuver. • Ideal for both indoor and outdoor applications. • Dry or wet grinding. • Standard 46 liters water tank 46 liters. • Tempered steel gear transmission.

Recommended batteries: battery 12V 550 ACC Class.

ESTIMATED PRODUCTION

Superconcrete 7 step	30-35m ² /h
Concrete Grinding 1 step	110-140m ² /h
Terrazzo Polishing 5 step	30-35m ² /h
Resin Removing 1 step	110-160m ² /h
Varnish Removing 1 step	110-160m ² /h

*Production numbers may vary according to surface conditions, diamonds used, equipment operator, etc.

TECHNICAL DATA

Model	Motor	Power	Propano tank	Speed Tools	Working Width	Tools Size	Water Tank	Dimensions WxHxD cm	Weight	Price
HERCULES 800 PROPANE 4H	Kawasaki FX850V	19,9kW	20lbs/9kg	500-950	800mm	4x240mm	46 lt	214x130x86	485 Kg	€ 22.750,00

DATA FOR SHIPPING

Vol. Packaging	Size Packaging	Weight
1,80 m ³	150x145x85 cm	500 kg

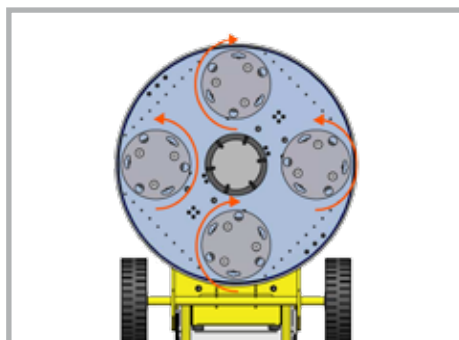

DCS ON: Satellites rotation only

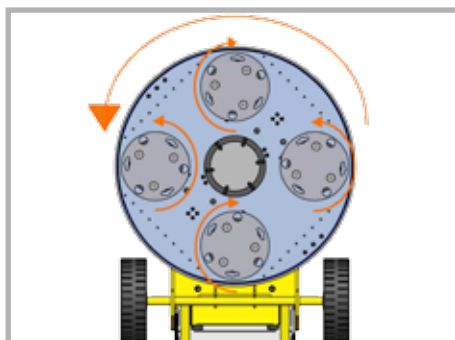

DCS OFF: Counter-rotating system



Intuitive control panel

Hercules 650 Propane



GRINDING

SINGLE DISC

TOOLS

SPECIAL

VACUUM

CHEMICALS

MARKETING

Floor grinder with "DCS System" and variable speed.



New "DCS" System Double Cutting System



Full metal gear box

Floor grinder with "DCS System" and variable speed.

Unique propane powered grinding and polishing machine with geared planetary and 3 headed DCS system. DCS system with 3 heads, allows short time in surface preparation, even in the most severe environments. With its 3 heads DCS system Hercules 650 Propane is considered as the most efficient surface preparation grinding machine in the market. Hercules 650 Propane combines performance and reliability of Klindex grinding and polishing machines with the flexibility of propane motor. Hercules 650 Propane allows independence from generators or power lines. His robust grinder combines its weight with a working section of 650mm, providing high productivity rates and constant performances. Hercules 650 Propane is great for outdoor applications where there is limited or no power options. Of course you also use the machine indoors, with good ventilation. **Main advantages:** • No performance drop and loss of time caused by the power grid. • Exclusive DCS system. • Free from the hassle and costs of extension cords in the yard. • No need of generator. • Accurate and reliable adjustable planetary speed. • Low operating vibrations. • Accommodation. • Light and easy to maneuver. • Ideal for both indoor and outdoor applications. • Dry or wet grinding. • Standard 46 liters water tank 46 liters. • Tempered steel gear transmission.

Recommended batteries: battery 12V 550 ACC Class.

ESTIMATED PRODUCTION

Superconcrete 7 step	15-20m ² /h
Concrete Grinding 1 step	60-100m ² /h
Terrazzo Polishing 5 step	15-20m ² /h
Resin Removing 1 step	60-100m ² /h
Varnish Removing 1 step	60-100m ² /h

*Production numbers may vary according to surface conditions, diamonds used, equipment operator, etc.

TECHNICAL DATA

Model	Motor	Power	Propano tank	Speed Tools	Working Width	Tools Size	Water Tank	Dimensions WxHxD cm	Weight	Price
HERCULES 650 PROPANE	Kawasaki FX850V	19,9kW	20lbs/9kg	700-1300	6500mm	3x240mm	46 lt	120x125x67	370 Kg	€ 18.395,00

DATA FOR SHIPPING

Vol. Packaging	Size Packaging	Weight
1,27 m ³	80x120x132 cm	397 kg

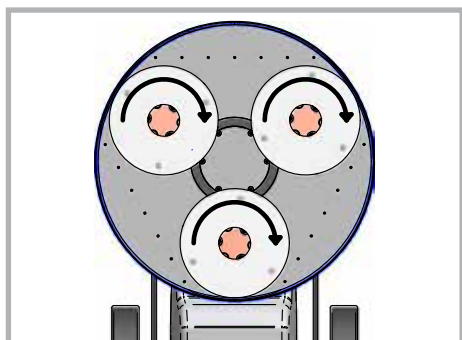

DCS ON: Satellites rotation only

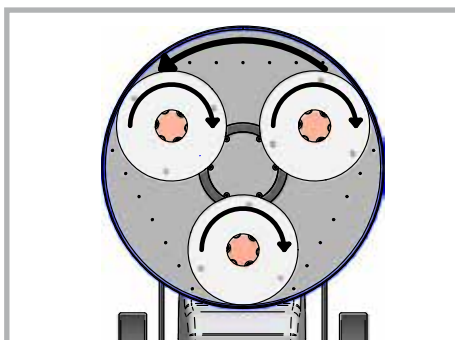

DCS OFF: Counter-rotating system



Hercules 800



Floor grinder with 4 HEADS
"DCS System" and variable speed.



New "DCS" System
Double Cutting System

First grinding machine in the world with 4 Heads DCS System.

Hercules series introduces the innovative DCS System that puts in one machine only the features of two different ones.

- Using the Hercules in counter rotating modality it is a performing grinding and polishing machine for concrete, marble and natural stone floors.
- Using the machine in DCS System modality the speed of the satellites is increased turning the Hercules in to a high performance industrial floor preparation machine. Suitable for fast removal of resins and glues, for fast exposing of the aggregates and for fast levelling of very uneven surfaces.

Main features: • Working width 800 mm with 4 size 240 mm tools. • Speed of tools ranging from 400 to 1300 rpm. • Strong gear box with thermo-hardened steel gears for a longer life. • No noise during the work. • Auto levelling Planetary System. • Unmistakable Italian design.

ESTIMATED PRODUCTION

Superconcrete 7 step	25-30m ² /h
Concrete Grinding 1 step	100-130m ² /h
Terrazzo Polishing 5 step	25-30m ² /h
Resin Removing 1 step	100-150m ² /h
Varnish Removing 1 step	100-150m ² /h
Marble Polishing 5 step	10-15m ² /h
Granite Polishing 7 step	6-10m ² /h

*Production numbers may vary according to surface conditions, diamonds used, equipment operator, etc.

TECHNICAL DATA

Model	Motor	Volt	Hertz	Amp	Speed Tools	Working Width	Tools Size	Water Tank	Dimensions WxHxD cm	Weight	Price
HERCULES 800 VS	15 Hp	380/480	50/60	32	400-1300 rpm	800 mm	4x240mm	46 l	214x130x86	385 kg	€ 16.975,00

DCS: DOUBLE CUTTING SYSTEM

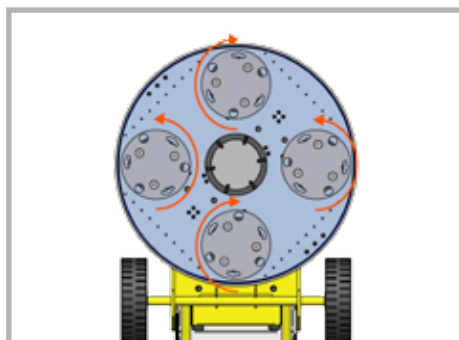

DCS ON: Satellites rotation only

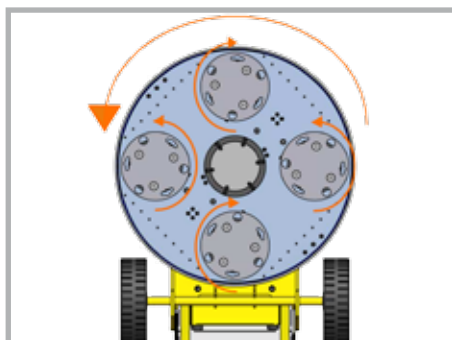

DCS OFF: Counter-rotating system

DATA FOR SHIPPING

Vol. Packaging	Size Packaging	Weight
1,80 m ³	150x145x85 cm	450 kg



DCS System ON/OFF

GRINDING

SINGLE DISC

TOOLS

SPECIAL

VACUUM

CHEMICALS

MARKETING

Hercules 750



Floor grinder with "DCS System" and variable speed.



New "DCS" System Double Cutting System



Full Metal gear box

First grinding machine in the world with DCS System.

Hercules series introduces the innovative DCS System that puts in one machine only the features of two different ones.

- Using the Hercules in counter rotating modality it is a performing grinding and polishing machine for concrete, marble and natural stone floors.
- Using the machine in DCS System modality the speed of the satellites is increased turning the Hercules in to a high performance industrial floor preparation machine. Suitable for fast removal of resins and glues, for fast exposing of the aggregates and for fast levelling of very uneven surfaces.

Main features: • Working width 750 mm with 3 size 340 mm tools. • Speed of tools ranging from 600 to 1300 rpm. • Strong gear box with thermo-hardened steel gears for a longer life. • No noise during the work. • Auto levelling Planetary System. • Unmistakable Italian design.

ESTIMATED PRODUCTION

Superconcrete 7 step	20-30m ² /h
Concrete Grinding 1 step	90-110m ² /h
Terrazzo Polishing 5 step	20-25m ² /h
Resin Removing 1 step	80-130m ² /h
Varnish Removing 1 step	80-130m ² /h
Marble Polishing 5 step	8-13m ² /h
Granite Polishing 7 step	5-7m ² /h

* Production numbers may vary according to surface conditions, diamonds used, equipment operator, etc.

TECHNICAL DATA

Model	Motor	Drive Inverter	Volt	Hertz	Amp	Speed Tools	Working Width	Tools Size	Water Tank	Dimensions WxHxD cm	Weight	Price
HERCULES 750 VS	10 Hp	11 kW	380/480	50/60	32	600-1300 rpm	750 mm	3x340mm	46 l	186x126x77	380 kg	€ 13.995,00
HERCULES 750 VS	15 Hp	11 kW	380/480	50/60	32	600-1300 rpm	750 mm	3x340mm	46 l	186x126x77	390 kg	€ 14.995,00

DCS: DOUBLE CUTTING SYSTEM

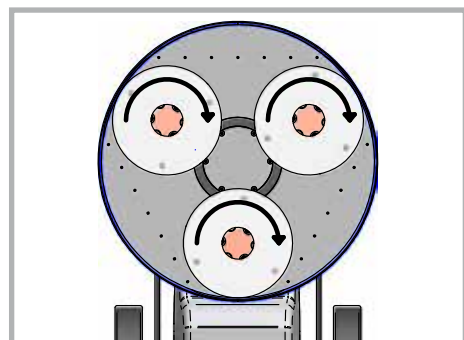

DCS ON: Satellites rotation only

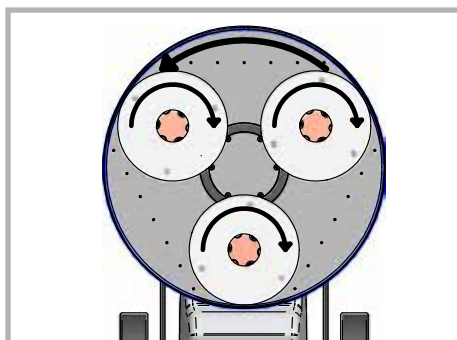

DCS OFF: Counter-rotating system

DATA FOR SHIPPING

Vol. Packaging	Size Packaging	Weight
1,80 m ³	150x145x85 cm	400 kg



DCS System ON/OFF

Hercules 650



GRINDING
SINGLE DISC
TOOLS
SPECIAL
VACUUM
CHEMICALS
MARKETING

Floor grinder with "DCS System" and variable speed.



New "DCS" System Double Cutting System



Full Metal gear box

First grinding machine in the world with DCS System.
Hercules series introduces the innovative DCS System that puts in one machine only the features of two different ones.

- Using the Hercules in counter rotating modality it is a performing grinding and polishing machine for concrete, marble and natural stone floors.
- Using the machine in DCS System modality the speed of the satellites is increased turning the Hercules in to a high performance industrial floor preparation machine. Suitable for fast removal of resins and glues, for fast exposing of the aggregates and for fast levelling of very uneven surfaces.

Main features: • Working width 650 mm with 3 size 240 mm tools. • Speed of tools ranging from 600 to 1300 rpm. • Strong gear box with thermo-hardened steel gears for a longer life. • No noise during the work. • Auto levelling Planetary System. • Unmistakable Italian design.

ESTIMATED PRODUCTION

Superconcrete 7 step	12-17m ² /h
Concrete Grinding 1 step	50-90m ² /h
Terrazzo Polishing 5 step	11-17m ² /h
Resin Removing 1 step	45-85m ² /h
Varnish Removing 1 step	45-85m ² /h
Marble Polishing 5 step	8-13m ² /h
Granite Polishing 7 step	5-8m ² /h

*Production numbers may vary according to surface conditions, diamonds used, equipment operator, etc.

TECHNICAL DATA

Model	Motor	Drive Inverter	Volt	Hertz	Amp	Speed Tools	Working Width	Tools Size	Water Tank	Dimensions WxHxD cm	Weight	Price
HERCULES 650 VS	10 Hp	7,5 kW	380/480	50/60	16	600-1300 rpm	650 mm	3x240mm	46 l	120x125x67	285 kg	€ 12.995,00
HERCULES 650 VS USA	10 Hp	11 kW 200 V Mono	200-240 1 or 3 Phase	50/60	30 Breaker	600-1300 rpm	650 mm	3x240mm	46 l	120x125x67	290 kg	€ 12.995,00

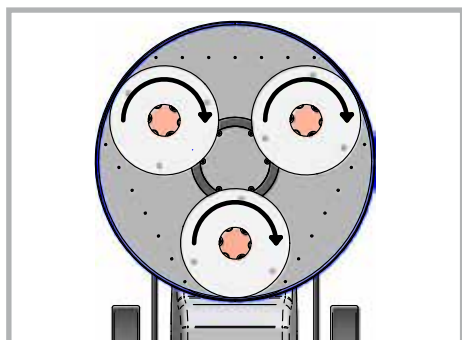

DCS ON: Satellites rotation only

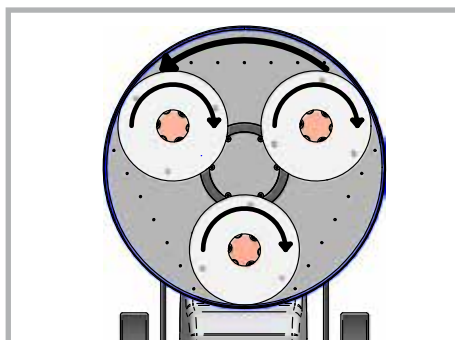

DCS OFF: Counter-rotating system

DATA FOR SHIPPING

Vol. Packaging	Size Packaging	Weight
1,31 m ³	120x80x136 cm	320 Kg



DCS System ON/OFF

Hercules 601



Floor grinder with "DCS System" and variable speed.



New "DCS" System
Double Cutting System



Full Metal gear box

ESTIMATED PRODUCTION

Superconcrete 7 step	10-15m ² /h
Concrete Grinding 1 step	40-80m ² /h
Terrazzo Polishing 5 step	9-15m ² /h
Resin Removing 1 step	40-80m ² /h
Varnish Removing 1 step	40-80m ² /h
Marble Polishing 5 step	7-12m ² /h
Granite Polishing 7 step	5-7m ² /h

*Production numbers may vary according to surface conditions, diamonds used, equipment operator, etc.

First grinding machine in the world with DCS System.

Hercules series introduces the innovative DCS System that puts in one machine only the features of two different ones. • Using the Hercules in counter rotating modality it is a performing grinding and polishing machine for concrete, marble and natural stone floors. • Using the machine in DCS System modality the speed of the satellites is increased turning the Hercules in to a high performance industrial floor preparation machine. Suitable for fast removal of resins and glues, for fast exposing of the aggregates and for fast levelling of very uneven surfaces. **Main features:** • Working width 600 mm with 3 size 240 mm tools. • Variable speed of tools. • Strong gear box with thermo-hardened steel gears for a longer life. • No noise during the work. • Auto levelling Planetary System.

TECHNICAL DATA

Model	Motor	Drive Inverter	Volt	Hertz	Amp	Speed Tools	Working Width	Tools Size	Water Tank	Dimensions WxHxD cm	Weight	Price
HERCULES 601	2900 Watt max	--	230 mono	50	--	800 rpm	600 mm	3x240mm	46 l	120x125x62	140 kg	€ 6.595,00
HERCULES 601 VS	3000 Watt max	4 kW 230V	230 mono	50/60	--	600-1000 rpm	600 mm	3x240mm	46 l	120x125x62	155 kg	€ 8.145,00
HERCULES 601 T5 VS	5,5 Hp	4 kW 380V	380-480	50/60	16	600-1000 rpm	600 mm	3x240mm	46 l	120x125x62	160 kg	€ 8.650,00
HERCULES 601 T7 VS	7 Hp	7,5 kW	380-480	50/60	16	600-1000 rpm	600 mm	3x240mm	46 l	120x125x62	160 kg	€ 9.850,00

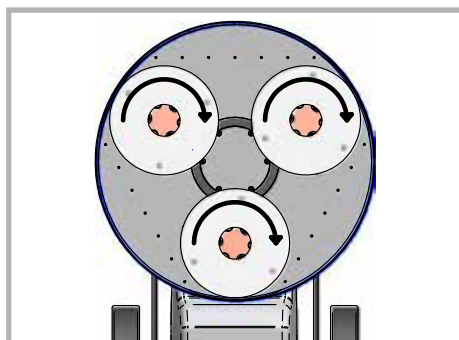

DCS ON: Satellites rotation only

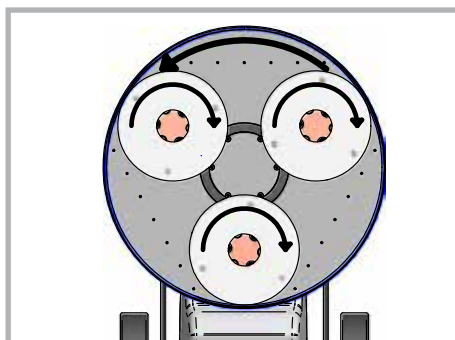

DCS OFF: Counter-rotating system

DATA FOR SHIPPING

Vol. Packaging	Size Packaging	Weight
0,72 m ³	120x80x75 cm	170 kg



DCS System ON/OFF

Hercules 551



Floor grinder with "DCS System" and variable speed.



New "DCS" System Double Cutting System

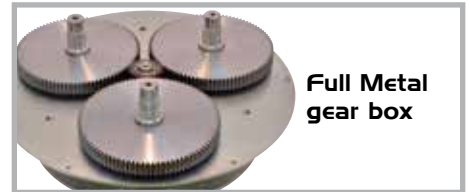

Full Metal gear box

ESTIMATED PRODUCTION

Superconcrete 7 step	8-12m ² /h
Concrete Grinding 1 step	35-70m ² /h
Terrazzo Polishing 5 step	8-12m ² /h
Resin Removing 1 step	35-70m ² /h
Varnish Removing 1 step	35-70m ² /h
Marble Polishing 5 step	6-10m ² /h
Granite Polishing 7 step	5-6m ² /h

*Production numbers may vary according to surface conditions, diamonds used, equipment operator, etc.

First grinding machine in the world with DCS System.
 Hercules series introduces the innovative DCS System that puts in one machine only the features of two different ones. • Using the Hercules in counter rotating modality it is a performing grinding and polishing machine for concrete, marble and natural stone floors. • Using the machine in DCS System modality the speed of the satellites is increased turning the Hercules in to a high performance industrial floor preparation machine. Suitable for fast removal of resins and glues, for fast exposing of the aggregates and for fast levelling of very uneven surfaces. **Main features:** • Working width 550 mm with 3 size 200 mm tools. • Variable speed of tools. • Strong gear box with thermo-hardened steel gears for a longer life. • No noise during the work. • Auto levelling Planetary System. • Unmistakable Italian design.

TECHNICAL DATA

Model	Motor	Drive Inverter	Volt	Hertz	Amp	Speed Tools	Working Width	Tools Size	Water Tank	Dimensions WxHxD cm	Weight	Price
HERCULES 551	2900 Watt max	--	220	50	--	800 rpm	550mm	3x200mm	46 l	120x125x57	135 kg	€ 5.795,00
HERCULES 551 VS	3000 Watt max	4 kW mono	220	50/60	--	400-1000 rpm	550mm	3x200mm	46 l	120x125x57	140 kg	€ 7.350,00
HERCULES 551 T5 VS	5,5 Hp	4 kW 3phase	380/480	50/60	16	600-1000 rpm	550mm	3x200mm	46 l	120x125x57	160 kg	€ 7.695,00

DATA FOR SHIPPING

Vol. Packaging	Size Packaging	Weight
0,80 m ³	90x70x128 cm	175 Kg

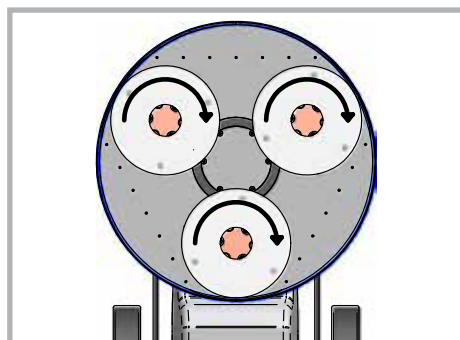

DCS ON: Satellites rotation only

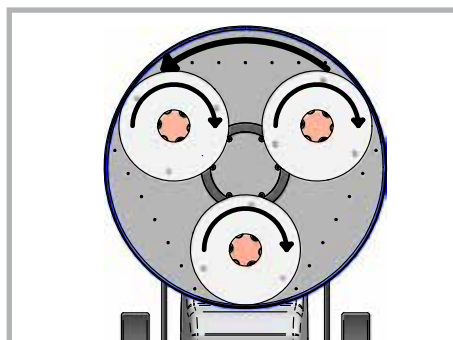

DCS OFF: Counter-rotating system



DCS System ON/OFF

GRINDING

SINGLE DISC

TOOLS

SPECIAL

VACUUM

CHEMICALS

MARKETING

Hercules 451



Floor grinder with "DCS System" and variable speed.



New "DCS" System Double Cutting System



Full Metal gear box

ESTIMATED PRODUCTION

Superconcrete 7 step	7-10m ² /h
Concrete Grinding 1 step	30-35m ² /h
Terrazzo Polishing 5 step	6-9m ² /h
Resin Removing 1 step	30-60m ² /h
Varnish Removing 1 step	30-60m ² /h
Marble Polishing 5 step	5-8m ² /h
Granite Polishing 7 step	4-6m ² /h

*Production numbers may vary according to surface conditions, diamonds used, equipment operator, etc.

First grinding machine in the world with DCS System.

Hercules series introduces the innovative DCS System that puts in one machine only the features of two different ones. • Using the Hercules in counter rotating modality it is a performing grinding and polishing machine for concrete, marble and natural stone floors. • Using the machine in DCS System modality the speed of the satellites is increased turning the Hercules in to a high performance industrial floor preparation machine. Suitable for fast removal of resins and glues, for fast exposing of the aggregates and for fast levelling of very uneven surfaces. **Main features:** • Working width 450 mm with 3 size 200 mm tools. • Variable speed of tools. • Strong gear box with thermo-hardened steel gears for a longer life. • No noise during the work. • Auto levelling Planetary System. • Unmistakable Italian design.

TECHNICAL DATA

Model	Motor Watt max	Drive Inverter	Volt	Hertz	Speed Tools	Working Width	Tools Size	Water Tank	Dimensions WxHxD cm	Weight	Price
HERCULES 451	2900	--	220	50	800 rpm	450mm	3x200mm	46 l	120x125x47	130 kg	€ 4.995,00
HERCULES 451 VS	3000	4 kW	220	50/60	600-1000 rpm	450mm	3x200mm	46 l	120x125x47	135 kg	€ 6.395,00
HERCULES 451 USA	1900	--	115	60	600 rpm	450mm	3x200mm	46 l	120x125x47	120 kg	€ 4.995,00
HERCULES 451 VS USA	1900	Lenze	115	60	400-900 rpm	450mm	3x200mm	46 l	120x125x47	125 kg	€ 6.395,00

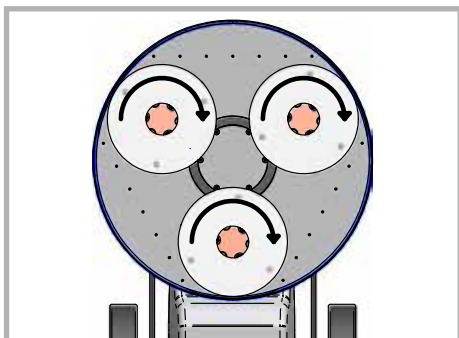

DCS ON: Satellites rotation only

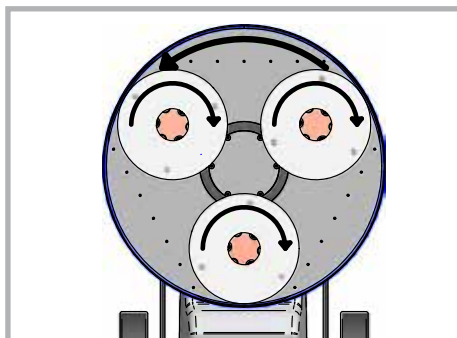

DCS OFF: Counter-rotating system

DATA FOR SHIPPING

Vol. Packaging	Size Packaging	Weight
0,72 m ³	120x80x75 cm	150 kg

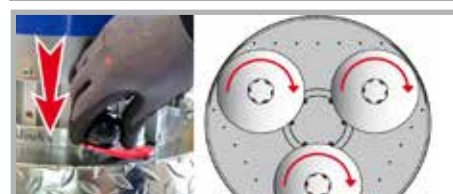

DCS System ON/OFF

Extra weights kit

GRINDING



Extra weights kit for Expander series.

Extra weights kit for Expander 950-850-750-650. The kit includes: 6 supports and 2 weight 20 Kg each designed for modular use. 3 different functions:

- Working position.
- Transportation position.
- Tools changing position to overturn the machine effortlessly.

TE031001	Extra weights kit	Expander 950 850 750 650	€ 895,00
TE82101	Extra weight 20 Kg		€ 310,00

SINGLE DISC



Working position



Transportation position



Tools changing position

TOOLS



Extra weights kit for Hercules series.

Extra weights kit for Hercules 800-750-650. The kit includes: 6 supports and 2 weight 20 Kg each designed for modular use. 3 different functions:

- Working position.
- Transportation position.
- Tools changing position to overturn the machine effortlessly.

TE030901	Extra weights kit	Hercules 800-750-650	€ 895,00
TE82101	Extra weight 20 Kg		€ 310,00

SPECIAL



Working position



Transportation position



Tools changing position

VACUUM



Extra weights kit for Expander 580-530

Extra weights kit for Expander 580 e 530. The kit includes: 4 supports and 2 weight 20 Kg each designed for modular use. 2 different functions:

- Working position.
- Transportation position.

TE031301	Extra weights kit	Expander 580-530	€ 710,00
TE82101	Extra weight 20 Kg		€ 310,00

CHEMICALS



Working position



Transportation position

MARKETING



 **klindex**[®]

Levighetor 650



GRINDING

SINGLE DISC

TOOLS

SPECIAL

VACUUM

CHEMICALS

MARKETING

Professional floor grinder complete of Planetary K1500.



Patented MONO-ROTATING planetary.

▶ LEVIGHETOR 650 is the ideal machine for grinding and polishing medium-large areas. Thanks to Planetary K1500 with a 20"/500mm working section and 8"/200mm tools it is particularly fast for polishing large areas. Very stable and easy to use. It can fit tools 8"/200mm or 3"/75mm. Thanks to the klindex' patented 360° directional wheels that allow to move the machine in any direction, the Levighetor 650 can work in both large and narrow areas like bathrooms and kitchens. With its powerful 4HP motor, the Levighetor 650 is the only mono-phase machine in the world that can work with additional weights for a total of up to 160kg (350lbs)

* The TOP version includes: Planetary Head K1500, tank, pad holder, brush, directional wheels, standard wheels and kit pad holder velcro baked 200mm.

ESTIMATED PRODUCTION

Superconcrete 7 step	8-12m ² /h
Concrete Grinding 1 step	40-60m ² /h
Terrazzo Polishing 5 step	10-15m ² /h
Resin Removing 1 step	40-60m ² /h
Varnish Removing 1 step	40-60m ² /h
Marble Polishing 5 step	8-12m ² /h
Granite Polishing 7 step	3-5m ² /h

*Production numbers may vary according to surface conditions, diamonds used, equipment operator, etc.

TECHNICAL DATA

Model	Motor	Volt	Hertz	Amp	Speed motor	Speed Tools	Working Width	Tools Size	Water Tank	Dimensions WxHxD cm	Weight	Price
LEVIGHETOR 650 TOP	2900 Watt max	220	50/60	--	155 rpm	1000 rpm	500mm	3x200mm	18 l	65x135x52	122 kg	€ 5.775,00
LEVIGHETOR 650 VS TOP	3000 Watt max	220	50/60	--	120-250 rpm	600-1300 rpm	500mm	3x200mm	18 l	65x135x52	133 kg	€ 7.395,00
LEVIGHETOR 650T4 TOP	5,5 HP	380	50/60	10	155 rpm	1000 rpm	500mm	3x200mm	18 l	65x135x52	122 kg	€ 5.775,00
LEVIGHETOR 650T5 VS	5,5 HP	380	50/60	10	155 rpm	300-1300 rpm	500mm	3x200mm	18 l	65x135x52	122 kg	€ 5.875,00

DATA FOR SHIPPING

Vol. Packaging	Size Packaging	Weight
0,72 m ³	120x80x75cm	156 Kg



Quick attack system



Planetary Head K1500 included

Levighetor 645



Professional floor grinder
complete of Planetary K1200.



Patented **MONO-ROTATING**
planetary.

▶ LEVIGHETOR 645 is the most versatile version of Levighetor series. Thanks to its Planetary Head K1200 and to 5.5" / 140mm tools, productivity increases. Levighetor 645 is the grinding and polishing machine for small to medium sized areas, ideal for apartments and civil applications. Perfect for all types of floor and processing such as: grinding and polishing of marble, granite, gres, terrazzo, concrete and industrial floors, the preparation of floors and surfaces, the removal of resins and glues and other type of treatments. Thanks to the klindex' patented 360° directional wheels that allow to move the machine in any direction, the Levighetor 645 can work in both large and narrow areas like bathrooms and kitchens. With its powerful 4HP motor, the Levighetor 645 is the only mono-phase machine in the world that can work with additional weights for a total of up to 160kg (350lbs)

* The TOP version includes: Planetary Head K1200, tank, pad holder, brush, directional wheels and standard wheels.

ESTIMATED PRODUCTION	
Superconcrete 7 step	6-9m ² /h
Concrete Grinding 1 step	30-50m ² /h
Terrazzo Polishing 5 step	6-9m ² /h
Resin Removing 1 step	18-35m ² /h
Varnish Removing 1 step	18-35m ² /h
Marble Polishing 5 step	6-9m ² /h
Granite Polishing 7 step	3-5m ² /h

*Production numbers may vary according to surface conditions, diamonds used, equipment operator, etc.

TECHNICAL DATA											
Model	Motor Watt max	Volt	Hertz	Speed motor	Speed Tools	Working Width	Tools Size	Water Tank	Dimensions WxHxD cm	Weight	Price
LEVIGHETOR 645 TOP	2900	220	50/60	155 rpm	1000 rpm	450mm	3x140mm	18 l	65x135x49	112 kg	€ 5.350,00
LEVIGHETOR 645 TOP VS	3000	220	50/60	120-250 rpm	600-1300 rpm	450mm	3x140mm	18 l	65x135x49	123 kg	€ 6.995,00



Quick attack system

DATA FOR SHIPPING		
Vol. Packaging	Size Packaging	Weight
0,45m ³	120x60x62cm	130 kg



Planetary Head K1200 included

Levighetor 640



Professional floor grinder complete of Planetary K1000.



Patented MONO-ROTATING planetary.

LEVIGHETOR 640 is the best selling grinding and polishing machine in the world. It comes with Planetary K1000 for 4"/100mm tools to achieve the best finishing. Ideal to work in apartments. Thanks to the klindex' patented 360° directional wheels that allow to move the machine in any direction, the Levighetor 640 can work in both large and narrow areas like bathrooms and kitchens. With its powerful 4HP motor, the Levighetor 640 is the only mono-phase machine in the world that can work with additional weights for a total of up to 160kg (350lbs).

Easy to disassemble in 3 parts for transport.

*The TOP version includes: Tank, pad holder, brush, directionable wheels and Planetary K1000 and standard wheels.

ESTIMATED PRODUCTION

Superconcrete 7 step	5-8m ² /h
Concrete Grinding 1 step	25-45m ² /h
Terrazzo Polishing 5 step	5-8m ² /h
Resin Removing 1 step	15-30m ² /h
Varnish Removing 1 step	15-30m ² /h
Marble Polishing 5 step	5-8m ² /h
Granite Polishing 7 step	3-5m ² /h

*Production numbers may vary according to surface conditions, diamonds used, equipment operator, etc.

TECHNICAL DATA

Model	Motor Watt max	Volt	Hertz	Speed motor	Speed Tools	Working Width	Tools Size	Water Tank	Dimensions WxHxD cm	Weight	Price
LEVIGHETOR 640 TOP	2900	220	50/60	200 rpm	1000 rpm	430mm	3x100mm	18 l	65x135x43	109 kg	€ 4.950,00
LEVIGHETOR 640 VS TOP	3000	220	50/60	120-250 rpm	600-1300 rpm	430mm	3x100mm	18 l	65x135x43	120 kg	€ 6.550,00

DATA FOR SHIPPING

Vol. Packaging	Size Packaging	Weight
0,45m ³	120x60x62cm	127 kg



Planetary Head K1000 included

GRINDING

SINGLE DISC

TOOLS

SPECIAL

VACUUM

CHEMICALS

MARKETING

Levighetor 600



Professional floor grinder basic.



Levighetor 600 is the most versatile professional floor machine. Equipped with planetary it can be turned in to a professional grinding and polishing machine. With brushes or floor pads it becomes the world's strongest single disc floor care machine. All heavy duty jobs can be performed thanks to its 4 or 7 HP powerful motors.

*BASIC version does not include any Accessories.

*The CPL version includes: Tank, pad holder and brush.

TECHNICAL DATA

Model	Motor	Volt	Hertz	Amp	Speed motor	Working Width	Water Tank	Dimensions WxHxD cm	Weight	Price
LEVIGHETOR 600 Basic	2900 Watt max	220	50/60	--	155 o 200 rpm	450mm	18 lt	60x121x38	59 Kg	€ 2.895,00
LEVIGHETOR 600 CPL	2900 Watt max	220	50/60	--	155 o 200 rpm	450mm	18 lt	60x121x38	63 Kg	€ 3.145,00
LEVIGHETOR 600 VS Basic	3000 Watt max	220	50/60	--	120-250 rpm	450mm	18 lt	60x121x38	68 Kg	€ 4.495,00
LEVIGHETOR 600 T4 Basic	4 HP	380	50/60	10	155 o 200 rpm	450mm	18 lt	60x121x38	75 Kg	€ 2.995,00
LEVIGHETOR 600 T5 Basic	5,5 HP	380	50/60	11	155 o 200 rpm	450mm	18 lt	60x121x38	78 Kg	€ 3.095,00
LEVIGHETOR 600 T5 VS Basic	5,5 HP	380	50/60	11	120-250 rpm	450mm	18 lt	60x121x38	80 Kg	€ 4.995,00



DATA FOR SHIPPING

Vol. Packaging	Size Packaging	Weight
0,45m ³	120x60x62cm	90 kg



Planetary Head not included

Rotoklin 320



GRINDING

SINGLE DISC

TOOLS

SPECIAL

VACUUM

CHEMICALS

MARKETING



- ▶ ROTOKLIN is a special machine designed for:
- Grinding very uneven floors.
 - Removal of resins, varnishes and glues.
 - Smoothing of joints.
 - Bush-Hammering concrete and stone floors.
 - Grinding and polishing floors.
 - Fast exposing of the aggregates.

ESTIMATED PRODUCTION	
Concrete Grinding 1 step	35-45m ² /h
Terrazzo Grinding 1 step	55-85m ² /h
Resin Removing 1 step	25-35m ² /h
Varnish Removing 1 step	15-35m ² /h

*Production numbers may vary according to surface conditions, diamonds used, equipment operator, etc.

TECHNICAL DATA											
Model	Motor	Volt	Hertz	Amp	Speed Tools	Working Width	Tools Size	Water Tank	Dimensions WxHxD cm	Weight	Price
ROKOKLIN 320	2900W max	220	50/60	--	1400 rpm	320mm	1x320mm	18 lt	75x120x35	77 Kg	€ 4.630,00
ROKOKLIN 320VS	3000W max	220	50/60	--	600-1600 rpm	320mm	1x320mm	18 lt	75x120x35	87 Kg	€ 5.995,00



DATA FOR SHIPPING		
Vol. Packaging	Size Packaging	Weight
0,45m ³	120x60x62cm	100 Kg



Rotoklin 240



**Single-disc floor grinder
4 HP single-phase with swiveling
grinding head.**

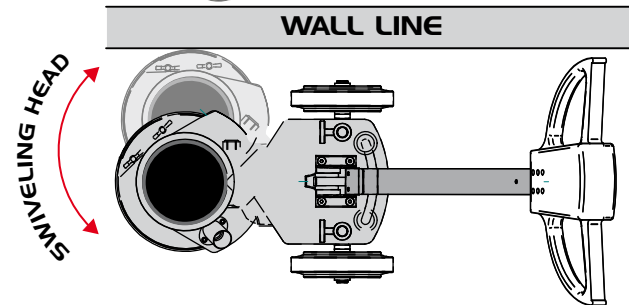

▶ ROTOKLIN 240 is a single-disc grinder designed for the preparation of horizontal small and medium surfaces.

Rotoklin 240 is very easy and convenient to use because it reduces drastically the vibrations to the operator, thanks to the optional connection to a Supervak suction it makes possible to work without dust.

Rotoklin 240 is the perfect machine for small and medium sizes surfaces treatments such as the preparation of flat surfaces, the levelling, the preparation of the concrete before painting, the removing of coating defects or adhesives, mastic, paints, resins and more, the repairing of damaged concrete, the grinding of rough surfaces, the restoration of rain marks, etc...

ESTIMATED PRODUCTION	
Concrete Grinding 1 step	20-25m ² /h
Terrazzo Grinding 1 step	45-75m ² /h
Resin Removing 1 step	15-25m ² /h
Varnish Removing 1 step	10-20m ² /h

*Production numbers may vary according to surface conditions, diamonds used, equipment operator, etc.

TECHNICAL DATA										
Model	Motor Watt max	Volt	Hertz	Speed Tools	Working Width	Tools Size	Water Tank	Dimensions WxHxD cm	Weight	Price
ROKOKLIN 240	2900	230	50	1400 rpm	240mm	1x240mm	18 l	70x110x25	53 kg	€ 2.675,00
ROKOKLIN 240VS	3000	230	50/60	800-2000 rpm	240mm	1x240mm	18 l	70x110x25	55 kg	€ 3.795,00
ROKOKLIN 240 USA	1900	110	60	1400 rpm	240mm	1x240mm	18 l	70x110x25	53 kg	€ 2.675,00
ROKOKLIN 240VS USA	1900	110	50/60	800-1600 rpm	240mm	1x240mm	18 l	70x110x25	55 kg	€ 3.795,00

DATA FOR SHIPPING		
Vol. Packaging	Size Packaging	Weight
0,45 m ³	120x60x62 cm	58 kg



CR Diamond Tools, Ideal to polish the concrete at the same level of the wall



Lateral inlet

DIAMOND TOOL FOR ROTOKLIN

PICTURE	CODE	NAME	SIZE	MACHINE	€ each
	BUSH HAMMER				
	UT022402	Bush Hammer 240	9,5"/ø240mm	Rotoklin 240	€ 1.095,00
	32030RTK	Bush Hammer 320	13"/ø320mm	Rotoklin 320	€ 995,00
	40030RTK	Bush Hammer 400	16"/ø400mm	Rotoklin 400	€ 1.795,00
	UT021101	Roller spare parts Spike			€ 295,00

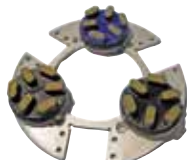
	TOOLS HOLDER PLATE A3 (ATTACK diameter 4"/ø100mm AS). To use diamond with AS attach ø100mm.				
	PD2701	Plate A3 - 240	9,5"/ø240mm	Rotoklin 240	€ 185,00
	UT34703	Plate A3 - 320	13"/ø320mm	Rotoklin 320	€ 235,00
	UT34901	Plate A3 - 400	16"/ø400mm	Rotoklin 400	€ 375,00

	SKRAPER RING (complete of PCD SKRAPER 70090X)				
	700910	Skraper 240 -4pcd	9,5"/ø240mm	Rotoklin 240	€ 425,00
	700911	Skraper 320 -6pcd	13"/ø320mm	Rotoklin 320	€ 435,00
	700912	Skraper 400 -8pcd	16"/ø400mm	Rotoklin 400	€ 595,00

TCK series Diamond tools with TCK technology for concrete floors.

	TCK 9,5"/ø240mm 12 Segments				
	240868	TCK00S grit 12	9,5"/ø240mm	Rotoklin 240	€ 399,00
	240869	TCK00 grit 20	9,5"/ø240mm	Rotoklin 240	€ 355,00
	240870	TCK0 grit 40	9,5"/ø240mm	Rotoklin 240	€ 260,00

	TCK 13"/ø320mm 12 Segments				
	320868	TCK00S grit 12	13"/ø320mm	Rotoklin 320	€ 439,00
	320869	TCK00 grit 20	13"/ø320mm	Rotoklin 320	€ 385,00
	320870	TCK0 grit 40	13"/ø320mm	Rotoklin 320	€ 290,00

	TCK 16"/ø400mm 16 Segments				
	400868	TCK00S grit 12	16"/ø400mm	Rotoklin 400	€ 535,00
	400869	TCK00 grit 20	16"/ø400mm	Rotoklin 400	€ 495,00
	400870	TCK0 grit 40	16"/ø400mm	Rotoklin 400	€ 395,00

DA series Diamond tools for medium-hard concrete. (Not for use on abrasive concrete).

	DA 9,5"/ø240mm 12 Segments				
	240825	DA00 grit 20	9,5"/ø240mm	Rotoklin 240	€ 285,00
	240826	DA0 grit 40	9,5"/ø240mm	Rotoklin 240	€ 198,00
	240827	DA1 grit 70	9,5"/ø240mm	Rotoklin 240	€ 198,00
	240828	DA2 grit 140	9,5"/ø240mm	Rotoklin 240	€ 198,00

	DA 13"/ø320mm 12 Segments				
	320819	DA00 grit 20	13"/ø320mm	Rotoklin 320	€ 295,00
	320820	DA0 grit 40	13"/ø320mm	Rotoklin 320	€ 215,00
	320821	DA1 grit 70	13"/ø320mm	Rotoklin 320	€ 215,00
	320822	DA2 grit 140	13"/ø320mm	Rotoklin 320	€ 215,00

	DA 16"/ø400mm 16 Segments				
	400819	DA00 grit 20	16"/ø400mm	Rotoklin 400	€ 345,00
	400820	DA0 grit 40	16"/ø400mm	Rotoklin 400	€ 275,00
	400821	DA1 grit 70	16"/ø400mm	Rotoklin 400	€ 275,00
	400822	DA2 grit 140	16"/ø400mm	Rotoklin 400	€ 275,00

GRINDING

SINGLE DISC

TOOLS

SPECIAL

VACUUM

CHEMICALS

MARKETING



Quick attack system



Ideal to work at same level of the wall

TRIPLEK

TRIPLES PRODUCTION
OF A SINGLE OPERATOR



Watch the VIDEO



Triple K

3 heads innovative single disc machine



GRINDING

SINGLE DISC

TOOLS

SPECIAL

VACUUM

CHEMICALS

MARKETING

New Klindex® Triple K: tripled productivity.

The 3-head single brush - Triple K - is a single-phase machine with variable speed. Thanks the extreme manoeuvrability, it is also a suitable solution to be used by an inexperienced operator, whose productivity is tripled thanks to 3 oscillating heads.

An ideal solution for polishing large surfaces, the New Triple K performs diamond grinding and polishing with polish. By mounting adjustable wheels that rest on the ground, crystallisation is performed effortlessly and moving the machine from one room to another is simple as it folds and goes through the normal doors in houses and offices.

TECHNICAL DATA

Model	Motor Watt max	Volt	Hertz	Speed	Working width	Water tank	Dimensions WxHxD cm	Weight	Price
TRIPLE K	3x1500	220	50/60	80-170 rpm	3x430mm (3x17")	18 lt	123x132x100 (working position) 70x132x100 (storage position)	155 Kg	€ 8.995,00

DATA FOR SHIPPING

Vol. Packaging	Size Packaging	Weight
0,94 m³	120x80x98 cm	170 kg



Tornado



GRINDING
SINGLE DISC
TOOLS
SPECIAL
VACUUM
CHEMICALS
MARKETING

High Speed Machine



▶ **HIGH SPEED MACHINE** for buffing and polishing floors. Thanks to the “integrated vacuuming system” it cleans and polishes with high productivity. With the 4 HP motor it is the most powerful mono-phase high speed machine in the world.

*Tornado includes dust control and pad holder.

TECHNICAL DATA

Model	Motor Watt max	Volt	Hertz	Speed	Working Width	Vacuum Tank	Dimensions WxHxD cm	Weight	Price
TORNADO 20"	2900	220	50/60	1500 o 1200 rpm	500mm (20")	8 lt	85x125x53	67 Kg	€ 4.725,00
TORNADO VS 20"	3000	220 or 380	50/60	700-1600 rpm	500mm (20")	8 lt	85x125x53	67 Kg	€ 5.750,00
TORNADO VS 24"	3000	220 or 380	50/60	700-1600 rpm	600mm (24")	8 lt	85x125x63	71 Kg	€ 5.950,00

ACCESSORIES TORNADO

UT023001	Kit Pad Holder	€ 470,00
30206	Discolux 20"	€ 14,40
04836	Emme2000	€ 90,00



DISCOLUX 20"
For polishing with Tornado.



DATA FOR SHIPPING

Vol. Packaging	Size Packaging	Weight
0,72 m³	120x80x72 cm	85 kg



EMME 2000
To be used with a regular or high-speed rotary cleaning machine and a red nylon pad.

Hurrikane propane



Propane High Speed Burnishing Machine.



GRINDING

SINGLE DISC

TOOLS

SPECIAL

VACUUM

CHEMICALS

MARKETING

The most powerful propane powered Klindex burnishing machine.
 Main advantages: • Suitable for large surfaces. • No limitations due to cables or lack of electric power. • High reliability with Kawasaki engines. • Compact design. • Heavy duty transmission. • No performance drop and loss of time caused by the power grid. • Free from the hassle and costs of extension cords in the yard. • No need of generator. • Accurate and reliable adjustable speed. • Low operating vibrations. • Light and easy to maneuver. • Ideal for both indoor and outdoor applications.
 Recommended batteries: battery 12V 550 ACC Class.

TECHNICAL DATA

Model	Motor	Power	Propane tank	Speed tools	Working width	Dimensions WxHxD cm	Weight	Price
HURRIKANE 24" Propane	Kawasaki FS603V	12,7kW	9Kg/20lbs	1000-2000rpm	600mm	151x85x63 cm	157 Kg	€ n.a.
HURRIKANE 26" Propane	Kawasaki FS603V	12,7kW	9Kg/20lbs	1000-2000rpm	650mm	151x85x67 cm	160 Kg	€ n.a.
HURRIKANE 28" Propane	Kawasaki FS603V	12,7kW	9Kg/20lbs	1000-2000rpm	700mm	151x85x78 cm	164 Kg	€ n.a.



9 Kg propane tank



Very compact design

DATA FOR SHIPPING		
Vol. Packaging	Size Packaging	Weight
1,13 m³	80x120x118 cm	170 Kg (24")



Kawasaki motor

Hurrikane



**High Speed
Burnishing machine**



GRINDING

SINGLE DISC

TOOLS

SPECIAL

▶ The first and the only one in the world! Powerful electric machine for polishing and buffing large areas. Advantages compared with propane buffing machines: easy to start, just plug it and work; no problem for safety, in many countries the "propane machines" are not allowed for indoor use. HURRIKANE can be used indoor our outdoor everywhere. No problem to work in any altitude like the propane machines. No need "to use and to transport propane". No need ADR for transport.

VACUUM

CHEMICALS

MARKETING

TECHNICAL DATA

Model	Motor	Volt	Hertz	Amp	Speed	Working Width	Dimensions WxHxD cm	Weight	Price
HURRIKANE 24" VS	5,5 HP	380/480	50/60	10	1000-1800 rpm	610mm (24")	151x85x63	75 Kg	€ 5.995,00
HURRIKANE 28" VS	10 HP	380/480	50/60	16	1100-1600 rpm	710mm (28")	165x104x78	150 kg	€ 10.950,00
HURRIKANE 28" VS	15 HP	380/480	50/60	20	1100-1600 rpm	710mm (28")	165x104x78	150 kg	€ 11.950,00



DATA FOR SHIPPING

Vol. Packaging	Size Packaging	Weight
1,12 m³	120x117x80 cm	193 Kg



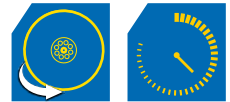

The most powerful single disc machine with 4 HP motor.



GRINDING

SINGLE DISC

TOOLS

SPECIAL

VACUUM

CHEMICALS

MARKETING

Kroma has been designed for heavy duty applications. With an innovative 4 HP motor it is the most powerful mono-rotary cleaning machine in the world. It is also available with a 2,5 - 3 - 4 HP motor. Thanks to its great range of available accessories it can solve any problem in the most economic way.

* The price does not include any accessories.

TECHNICAL DATA

Model	Motor Watt max	Volt	Hertz	Speed	Working Width	Water Tank	Dimensions WxHxD cm	Weight	Price
KROMA 17" HD	1900	220	50	150 rpm	430mm (17")	18 l	61x118x43	53 kg	€ 1.595,00
KROMA 18" HD	1900	220	50	150 rpm	450mm (18")	18 l	61x118x45	53 kg	€ 1.655,00
KROMA 21" HD	1900	220	50	150 rpm	530mm (21")	18 l	61x118x53	57 kg	€ 1.755,00
KROMA 17" TOP	2200	220	50/60	125/150/250 rpm	430mm (17")	18 l	61x118x43	53 kg	€ 2.395,00
KROMA 18" TOP	2200	220	50/60	125/150/250 rpm	450mm (18")	18 l	61x118x45	53 kg	€ 2.495,00
KROMA 21" TOP	2200	220	50/60	125/150/250 rpm	530mm (21")	18 l	61x118x53	65 kg	€ 2.595,00
KROMA 17" TOP	2900	220	50/60	125/150/250 rpm	430mm (17")	18 l	61x118x43	53 kg	€ 2.695,00
KROMA 18" TOP	2900	220	50/60	125/150/250 rpm	450mm (18")	18 l	61x118x45	53 kg	€ 2.695,00
KROMA 21" TOP	2900	220	50/60	125/150/250 rpm	530mm (21")	18 l	61x118x53	57 kg	€ 2.795,00
KROMA 17" VS TOP	3000	220	50/60	150 - 350 rpm	430mm (17")	18 l	61x118x43	53 kg	€ 4.195,00
KROMA 18" VS TOP	3000	220	50/60	150 - 350 rpm	450mm (18")	18 l	61x118x45	53 kg	€ 4.295,00
KROMA 21" VS TOP	3000	220	50/60	150 - 350 rpm	530mm (21")	18 l	61x118x53	57 kg	€ 4.395,00

* Also available with 220 Volt or 110 Volt motor.



DATA FOR SHIPPING

Vol. Packaging	Size Packaging	Weight
0,45 m ³	120x60x62 cm	81 kg

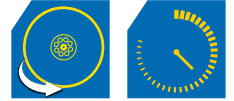

GRINDING

SINGLE DISC

TOOLS

SPECIAL

VACUUM

CHEMICALS

MARKETING

VARIABLE SPEED single disc machine from 50 to 450 rpm and 3 HP motor.



FUTURA is the first variable speed mono-rotary floor machine from 50 to 500 rpm! Thanks to this technological innovation, with only one machine it is now possible to perform an incredible range of works including scrubbing, polishing, honing, crystallization, vitrification, etc. Futura is the most silent scrubber machine.

*The basic price of machines does not include any accessories.

*The CPL version includes: tank, pad holder, brush.

TECHNICAL DATA

Model	Motor Watt max	Volt	Hertz	Speed	Working Width	Water Tank	Dimensions WxHxD cm	Weight	Price
FUTURA 17 BASIC	2200	220	50/60	50-450 rpm	430mm (17")	18 l	60x120x43	56 kg	€ 3.295,00
FUTURA 18 BASIC	2200	220	50/60	50-450 rpm	450mm (18")	18 l	60x120x45	56 kg	€ 3.395,00
FUTURA 21 BASIC	2200	220	50/60	50-450 rpm	530mm (21")	18 l	60x120x53	57 kg	€ 3.495,00
FUTURA 17 CPL	2200	220	50/60	50-450 rpm	430mm (17")	18 l	60x120x43	56 kg	€ 3.550,00
FUTURA 18 CPL	2200	220	50/60	50-450 rpm	450mm (18")	18 l	60x120x45	56 kg	€ 3.650,00
FUTURA 21 CPL	2200	220	50/60	50-450 rpm	530mm (21")	18 l	60x120x53	57 kg	€ 3.795,00



DATA FOR SHIPPING		
Vol. Packaging	Size Packaging	Weight
0,45 m³	120x60x62 cm	68 kg





Professional Single disc machine



GRINDING

SINGLE DISC

TOOLS

SPECIAL

VACUUM

CHEMICALS

MARKETING

UNIKA is the mono-rotary machine recognized world-wide for its innovative characteristics with the NOMINATION FOR THE MOST INNOVATIVE PRODUCT OF THE YEAR 2000 at INTERCLEAN - AMSTERDAM. Thanks to its great range of available accessories it can solve any problem in the most economic way.

*The basic price of any machine does not include any accessories.

*The CPL version includes: tank, pad holder, brush.

TECHNICAL DATA

Model	Motor Watt max	Volt	Hertz	Speed	Working Width	Water Tank	Dimensions WxHxD cm	Weight	Price
UNIKA 17 BASIC	1450	220	50/60	125 or 150 or 250 rpm	430mm (17")	18 l	55x118x43	41 kg	€ 1.595,00
UNIKA 18 BASIC	1450	220	50/60	125 or 150 or 250 rpm	450mm (18")	18 l	55x118x45	41 kg	€ 1.655,00
UNIKA 21 BASIC	1450	220	50/60	125 or 150 or 250 rpm	530mm (21")	18 l	55x118x53	44 kg	€ 1.855,00
UNIKA 17 CPL	1450	220	50/60	125 or 150 or 250 rpm	430mm (17")	18 l	55x118x43	41 kg	€ 1.795,00
UNIKA 18 CPL	1450	220	50/60	125 or 150 or 250 rpm	450mm (18")	18 l	55x118x45	41 kg	€ 1.895,00
UNIKA 21 CPL	1450	220	50/60	125 or 150 or 250 rpm	530mm (21")	18 l	55x118x53	44 kg	€ 1.995,00



DATA FOR SHIPPING		
Vol. Packaging	Size Packaging	Weight
0,45 m ³	120x60x62 cm	69 kg



Rocky



GRINDING

SINGLE DISC

TOOLS

SPECIAL

VACUUM

CHEMICALS

MARKETING

Multipurpose single disc machine



Rocky is the ideal rotary cleaner for cleaning and polishing any kind of floors. Thanks to its great range of available accessories it can solve any problem in the best and least expensive way. This new machine is available with very competitive prices.

*The basic price of machines does not include any accessories.

*The CPL version includes: tank, pad holder, brush.

TECHNICAL DATA

Model	Motor Watt max	Volt	Hertz	Speed	Working Width	Water Tank	Dimensions WxHxD cm	Weight	Price
ROCKY 13 BASIC	1300	220	50/60	155 rpm	330mm (13")	18 l	55x118x33	36 kg	€ 1.195,00
ROCKY 17 BASIC	1300	220	50/60	155 rpm	430mm (17")	18 l	55x118x43	41 kg	€ 1.195,00
ROCKY 18 BASIC	1300	220	50/60	155 rpm	450mm (18")	18 l	55x118x45	41 kg	€ 1.295,00
ROCKY 21 BASIC	1300	220	50/60	155 rpm	530mm (21")	18 l	55x118x53	44 kg	€ 1.450,00
ROCKY 13 CPL	1300	220	50/60	155 rpm	330mm (13")	18 l	55x118x33	36 kg	€ 1.365,00
ROCKY 17 CPL	1300	220	50/60	155 rpm	430mm (17")	18 l	55x118x43	41 kg	€ 1.450,00
ROCKY 18 CPL	1300	220	50/60	155 rpm	450mm (18")	18 l	55x118x45	41 kg	€ 1.550,00
ROCKY 21 CPL	1300	220	50/60	155 rpm	530mm (21")	18 l	55x118x53	44 kg	€ 1.750,00



DATA FOR SHIPPING

Vol. Packaging	Size Packaging	Weight
0,45 m³	120x60x62 cm	69 kg



Bella 20"

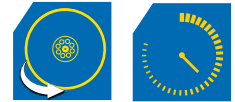

Innovative multi-purpose polishing machine.



Bella Basic: is fitted with fixed wheels and any accessories are optional.

Bella Top includes: adjustable wheels, planetary connection and carrying handle, any accessories are optional.

Bella is the innovative multifunction single disc born in Klindex home. Available with powerful motors from 1300 Watt max up to 2900 Watt max also in Variable speed version. Bella is the ideal floor care machine for cleaning, treatment, grinding and polishing of any surface. BELLA features all the interchangeable accessories to overcome all challenges that occur at construction sites. **Main Features:** • Ergonomically designed handle with hand protection • Reinforced handle rod • Carter in shockproof and scratchproof polyurethane material. • Predisposition for vacuum hood. • Release water in the Centre of the pad holder. • New compact and modern Made in Italy design • Large wheels adjustable in height for different works and for an easy transport • Wide range of handle's adjusting positions to permit comfortable working. • Ergonomic carrying handle (standard for the Top version). • Big water tank: 18-liter tank. • Predisposition to the use of extra weights. • Power outlet for accessories (optional). • Led lamp for working in poorly lit environments (optional).

TECHNICAL DATA

Model	Motor Watt max	Volt	Hertz	Speed motor	Working Width	Water Tank	Dimensions WxHxD cm	Weight	Price
BELLA BASIC 1300	1300	230	50	140 rpm	500mm (20")	18 l	70x126x50	34 kg	€ 1.795,00
BELLA TOP 2200	2200	230	50	140 rpm	500mm (20")	18 l	70x126x50	42 kg	€ 2.095,00
BELLA TOP 2900	2900	230	50	140 rpm	500mm (20")	18 l	70x126x50	49 kg	€ 2.395,00
BELLA TOP 2900 VS	2900	230	50	95-165 rpm	500mm (20")	18 l	70x126x50	49 kg	€ 3.995,00



Adjustable wheels



Led light optional

DATA FOR SHIPPING		
Vol. Packaging	Size Packaging	Weight
0,45 m ³	120x60x62 cm	69 Kg



Handle for an easy transport

Bella Stone



GRINDING
SINGLE DISC
TOOLS
SPECIAL
VACUUM
CHEMICALS
MARKETING

Innovative multi-purpose polishing machine.



Bella Stone K3 includes: adjustable wheels, water tank, carrying handle, K3 planetary, 3 pad holders 140mm, splash guard, pad holder 450mm, polishing brush 450mm.

Bella is the innovative multifunction single disc born in Klindex home. Available with powerful motors from 2200 Watt max up to 2900 Watt max also in Variable speed version. Bella is the ideal floor care machine for cleaning, treatment, grinding and polishing of any surface. BELLA features all the interchangeable accessories to overcome all challenges that occur at construction sites. **Main Features:** • Ergonomically designed handle with hand protection • Reinforced handle rod • Carter in shockproof and scratchproof polyurethane material. • Predisposition for vacuum hood. • Release water in the Centre of the pad holder. • New compact and modern Made in Italy design • Large wheels adjustable in height for different works and for an easy transport • Wide range of handle's adjusting positions to permit comfortable working. • Ergonomic carrying handle (standard for the Top version). • Big water tank: 18-liter tank. • Predisposition to the use of extra weights. • Power outlet for accessories (optional). • Led lamp for working in poorly lit environments (optional).

TECHNICAL DATA

Model	Motor Watt max	Volt	Hertz	Speed motor	Working Width	Planetary Tools size	Water Tank	Dimensions WxHxD cm	Weight	Price
BELLA STONE 2200 K3	2200	230	50	140 rpm	450mm (18")	3x140mm	18 l	70x126x50	78 kg	€ 3.895,00
BELLA STONE 2900 K3	2900	230	50	140 rpm	450mm (18")	3x140mm	18 l	70x126x50	78 kg	€ 4.295,00
BELLA STONE 2900 K3 VS	2900	230	50	95-165 rpm	450mm (18")	3x140mm	18 l	70x126x50	78 kg	€ 5.695,00



Adjustable wheels



DATA FOR SHIPPING		
Vol. Packaging	Size Packaging	Weight
0,72 m ³	80x12x72 cm	92 Kg



Handle for an easy transport

K3 Planetary

Gear protection against dust and slurry

NEW



New K3 Planetary: is designed exclusively for the BELLÀ, allow to sand, grind and polish any kind of surfaces. Thanks to its quick attach system the connection to the machine takes only few seconds. The gears are protected from the contact with dirt, sludge and dust ensuring optimum functionality and durability. The outlet at the center of the planetary reduces the use of water, improves the performance of diamond disks ensuring working homogeneity.

Easy to use, provides a perfectly flat and smooth surface. It is easy to use even in tight spaces.

Applications:

- Grinding and polishing of marble and granite
- Leveling of screeds.
- Grinding and polishing of concrete.
- Sanding of wooden floor and ideal for prefinished parquet.



SPLASH GUARD

AP8403 K3, K4 Splash guard € 68,00



MARBLE PLANETARY

LU2501MARMO K3 - 3 heads € 1.350,00



PAD HOLDER

47001 Pad holder 18"ø450mm € 98,00



LIQUID TANK

SE4501 Liquid Tank 18Lt € 131,00



EXTRA WEIGHTS KIT - 8,5Kg

CA017502 Extra weight with support € 125,00



LED LIGHT KIT

TE026301 Led light Kit € 330,00

GRINDING

SINGLE DISC

TOOLS

SPECIAL

VACUUM

CHEMICALS

MARKETING

Maxi Orbit



GRINDING

SINGLE DISC

TOOLS

SPECIAL

VACUUM

CHEMICALS

MARKETING



The advanced roto-orbital single disc.



MaxiOrbit includes: pad holder and 2 extra weights.

Maxi Orbit, the advanced professional multipurpose single brush which makes it easy and quick working on all surfaces. Suitable for treatments such as • polishing, • dewaxing, • crystallization • light grinding on marble, concrete, stone, parquet, terracotta and stoneware, Maxi Orbit is also ideal for cleaning delicate surfaces such as carpets and rugs. The oscillating head adapts to all surfaces and allows to work easily even on uneven surfaces minimizing user fatigue. The great number of accessories and the big wheels on the ground make working simple and efficient. Thanks to its high-frequency oscillations roto-orbital principle, Maxi Orbit amazes for the excellent stability and manoeuvrability making the crystallization operations with steel wool fast, easy and effortless. The robust and compact chassis, the reinforced rod's ergonomic handle, the large wheels, its low weight and the release system of the main components (optional), make of the Maxi Orbit a strong machine very easy to carry

TECHNICAL DATA

Model	Motor Watt max	Volt	Hertz	Speed	Working width	Water tank	Dimensions WxHxD cm	Weight	Price
MAXI ORBIT 1500	1500	230	50	1400 rpm	430mm (17")	18 lt	70x43x128	40 Kg	€ 1.795,00
MAXI ORBIT 3000	3000	230	50	1400 rpm	430mm (17")	18 lt	70x43x128	52 Kg	€ 2.595,00

DATA FOR SHIPPING

Vol. Packaging	Size Packaging	Weight
0,45 m³	120x60x62 cm	69 Kg



Kit Sprayer 15lt. € 359,00



Extra weights kit 6Kg each



Handle for an easy lift



Cleaning fitted carpeting and rugs

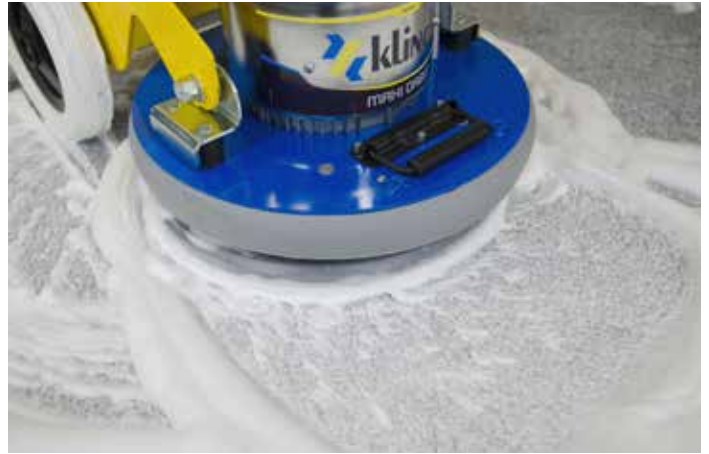

Shampooing fitted carpeting and rugs



Crystallization



Micro-grinding of natural stone



Cleaning and polishing gres



De-waxing linoleum, PVC and rubber



Grinding and sanding parquet



Oil finishing for parquet with raised wheels

GRINDING

SINGLE DISC

TOOLS

SPECIAL

VACUUM

CHEMICALS

MARKETING

Mini Orbit



GRINDING

SINGLE DISC

TOOLS

SPECIAL

VACUUM

CHEMICALS

MARKETING

Roto-orbital single brush



Mini Orbit, the advanced professional multi-purpose single brush which makes it easy and quick working on all surfaces. Suitable for treatments such as • polishing, • de-waxing, • crystallization • light grinding on marble, concrete, stone, parquet, terracotta and stoneware, Mini Orbit is also ideal for cleaning delicate surfaces such as carpets and rugs. The oscillating head adapts to all surfaces and allows to work easily even on uneven surfaces minimizing user fatigue. The great number of accessories make working simple and efficient. Thanks to its high-frequency oscillations roto-orbital principle, Mini Orbit amazes for the excellent stability and manoeuvrability making the crystallization operations with steel wool fast, easy and effortless. The robust and compact chassis, the ergonomic handle and its low weight makes of the Mini Orbit a strong machine very easy to carry.

TECHNICAL DATA

Model	Motor Watt	Volt	Hertz	Speed	Working width	Dimensions WxHxD cm	Weight	Price
MINI ORBIT	250	230	50	1400 rpm	280mm (11")	32x124x32	15 Kg	€ 950,00





Cleaning fitted carpeting and rugs



Shampooing fitted carpeting and rugs



Crystallization



Micro-grinding of natural stone



Cleaning and polishing gres



De-waxing linoleum, PVC and rubber

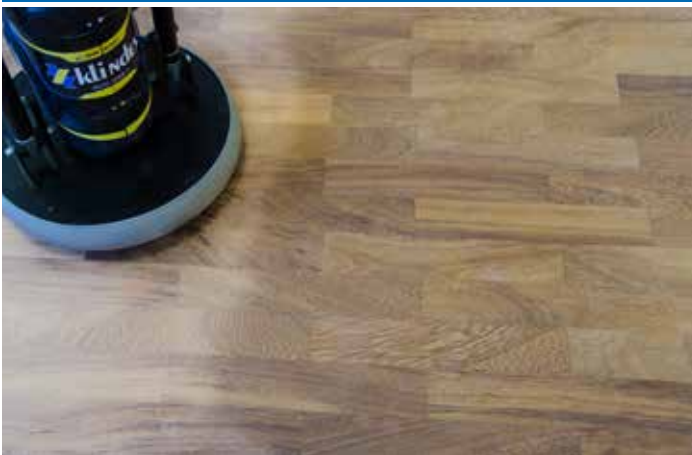

Grinding and sanding parquet



Oil finishing for parquet

GRINDING

SINGLE DISC

TOOLS

SPECIAL

VACUUM

CHEMICALS

MARKETING

BRUSHES, PAD HOLDERS AND ADAPTER CLUTCH

PICTURE	CODE	NAME	SIZE	MACHINE	€ each
	CLUTCH: MODULAR ADAPTER				
	506130NCM10	Clutch - modular adapter		Unika, Kroma Top, Levighetor, Timba	€ 29,50
	506140KLM10	Clutch - modular adapter		Futura, Rocky, Kroma HD	€ 33,50
	506140COM10	Clutch - modular adapter		Bella	€ 33,50
	PAD HOLDER BASIC WITHOUT ADAPTER CLUTCH				
	The prices of pad holders does not include the Adapter Clutch. Please specify if you also want the Clutch.				
	526113	Pad Holder 13"	13"/ø330mm	For any machine 13"	€ 52,00
	526117	Pad Holder 17"/18"	17"/ø430mm-18"/ø450mm	For any machine 17" and 18"	€ 82,00
	526120	Pad Holder 20"	20"/ø500mm	For any machine 20"	€ 98,00
526121	Pad Holder 21"	21"/ø530mm	For any machine 21"	€ 105,00	
	STANDARD BRUSH WITHOUT ADAPTER CLUTCH - FOR MAINTENANCE				
	The prices of brushes does not include the Adapter Clutch. Please specify if you also want the Clutch. The adapter clutch can be reused when the brush has worn out.				
	626113P1	Nylon Brush	13"/ø330mm	For any machine 13"	€ 42,50
	626117P1	Nylon Brush	17"/ø430mm	For any machine 17" and 18"	€ 52,50
	626120P1	Nylon Brush	20"/ø500mm	For any machine 20"	€ 78,50
626121P1	Nylon Brush	21"/ø530mm	For any machine 21"	€ 79,00	
	SOFT BRUSH WITHOUT ADAPTER CLUTCH - FOR CARPET CLEANING				
	The prices of brushes does not include the Adapter Clutch. Please specify if you also want the Clutch. The adapter clutch can be reused when the brush has worn out.				
	626113P3	Soft Brush	13"/ø330mm	For any machine 13"	€ 46,50
	626117P3	Soft Brush	17"/ø430mm	For any machine 17" and 18"	€ 57,50
	626120P3	Soft Brush	20"/ø500mm	For any machine 20"	€ 85,50
626121P3	Soft Brush	21"/ø530mm	For any machine 21"	€ 87,50	
	POLISHING BRUSH WITHOUT ADAPTER CLUTCH				
	The prices of brushes does not include the Adapter Clutch. Please specify if you also want the Clutch. The adapter clutch can be reused when the brush has worn out.				
	626113U	Polishing Brush	13"/ø330mm	For any machine 13"	€ 56,50
	626117U	Polishing Brush	17"/ø430mm	For any machine 17" and 18"	€ 82,50
	626120U	Polishing Brush	20"/ø500mm	For any machine 20"	€ 92,00
626121U	Polishing Brush	21"/ø530mm	For any machine 21"	€ 98,00	
	HARD BRUSH WITHOUT ADAPTER CLUTCH - FOR HEAVY DUTY CLEANING				
	The prices of brushes does not include the Adapter Clutch. Please specify if you also want the Clutch. The adapter clutch can be reused when the brush has worn out.				
	626113S	Winnex Brush	13"/ø330mm	For any machine 13"	€ 105,00
	626117S	Winnex Brush	17"/ø430mm	For any machine 17" and 18"	€ 159,00
	626120S	Winnex Brush	20"/ø500mm	For any machine 20"	€ 220,00
626121S	Winnex Brush	21"/ø530mm	For any machine 21"	€ 258,00	

GRINDING

SINGLE DISC

TOOLS

SPECIAL

VACUUM

CHEMICALS

MARKETING

ACCESSORIES FOR FLOOR CARE MACHINES

PICTURE	CODE	NAME	SIZE	MACHINE	€ each
	PAD HOLDER FOR ABRASIVE SANDPAPERS				
	45027	Pad Holder Sand paper	17"/ø430mm	Single Discs, Levighetor, Timba	€ 122,50
	45027FUT	Pad Holder Sand paper	17"/ø430mm	Futura, Rocky	€ 122,50
	45027BEL	Pad Holder Sand paper	17"/ø430mm	Bella	€ 122,50
	45027MAXIORB	Pad Holder Sand paper	17"/ø430mm	Maxi Orbit	€152,00
	STEEL BRUSH				
	43009	Steel Brush	17"/ø430mm	Single Discs	€ 109,00
	45009	Steel Brush	18"/ø450mm	Single Discs, Levighetor	€ 115,50
	43009FUT	Steel Brush	17"/ø430mm	Futura, Rocky	€ 118,00
	45009FUT	Steel Brush	18"/ø450mm	Futura, Rocky	€ 118,00
	45009BEL	Steel Brush	18"/ø450mm	Bella	€ 129,00
	43010	Steel Brush	17"/ø430mm	Maxi Orbit	€ 105,00
	STEEL WOOL				
	04863	Steel wool	17"/ø430mm	Box 12 pcs	€ 125,50
	43066	Pad Holder Steel wool	17"/ø430mm	Single Discs	€ 135,00
	43066FUT	Pad Holder Steel wool	17"/ø430mm	Futura, Rocky	€ 145,00
	43066	Pad Holder Steel wool	17"/ø430mm	Levighetor, Timba	€ 135,00
	EXTRA WEIGHT FOR LEVIGHETOR - HERCULES				
	CA51001	Extra Weight	17 kg	Levighetor, Hercules 450-550	€ 165,00
	EXTRA WEIGHT FOR SINGLE DISC MACHINES				
	PG983	Extra Weight	5 kg	Unika, Kroma, Rocky, Futura	€ 65,00
	EXTRA WEIGHT				
	CA51001Z	Extra Weight	17 Kg	Kroma	€ 195,00
	WATER TANK				
	45000	Tank 12	12lt	Single Discs, Lev.	€ 108,50
	46000	Tank 18	18lt	Single Discs, Lev.	€ 121,50
	SE4501	Tank 18 new	18lt	Single Discs, Lev.	€ 131,00

GRINDING

SINGLE DISC

TOOLS

SPECIAL

VACUUM

CHEMICALS

MARKETING

GRINDING

PICTURE	CODE	NAME	SIZE	MACHINE	€ each
	MULTIDISK ø430mm (17"). It Can be applied to any mono-rotary floor machine. By increasing the speed of the diamond pads it makes the job faster and better than using a regular pad-holder.				
	430140	Multidisk 430 (AS Ø140)	17"/ø430mm	Unika, Kroma	€ 495,00
	430100	Multidisk 430 (AS Ø100)	17"/ø430mm	Unika, Kroma	€ 495,00
	430140FUT	Multidisk 430 (AS Ø140)	17"/ø430mm	Futura, Rocky	€ 495,00
	430100FUT	Multidisk 430 (AS Ø100)	17"/ø430mm	Futura, Rocky	€ 495,00
	AP4101	Splash Guard for Multidisk 430	17"/ø430mm	Multidisk 430	€ 67,50

SINGLE DISC

	EASY PLATE ø430mm (17"). Velcro backed pad holder to accommodate velcro backed diamond disc.				
	430161	Easy Plate 430	17"/ø430mm	Unika, Kroma	€ 148,00
	430161FUT	Easy Plate 430	17"/ø430mm	Futura, Rocky	€ 148,00
	430161BEL	Easy Plate 430	17"/ø430mm	Bella	€ 148,00

TOOLS

	FRANKFURT PLATE. Plate holder to use FRANKFURT tools.				
	02590	Frankfurt Plate A3	17"/ø430mm	Unika, Kroma, Levighetor	€ 165,00
	02591	Frankfurt Plate A5	21"/ø530mm	Unika, Kroma, Levighetor	€ 205,00
	02590FUT	Frankfurt Plate A3	17"/ø430mm	Futura, Rocky	€ 165,00
	02591FUT	Frankfurt Plate A5	21"/ø530mm	Futura, Rocky	€ 205,00
	02590BEL	Frankfurt Plate A3	17"/ø430mm	Bella	€ 165,00

SPECIAL

	FIXED PLATE A3 ø430mm (17") Pad holder with three attachments to use diamond discs, carborundum, tytan and antique brushes ø100mm.				
	00801	Aluminium fixed plate A3	17"/ø430mm	Unika, Kroma, Levighetor	€ 325,00
	00801FUT	Aluminium fixed plate A3	17"/ø430mm	Futura, Rocky	€ 325,00
	00801BEL	Aluminium fixed plate A3	17"/ø430mm	Bella	€ 325,00

VACUUM

	KDT - THERMAL DISC A special patented attachment disc for mono-rotary floor machines. It is designed to heat up the surface of the floor by friction (no electric power) making the crystallization process easier, faster and better.				
	KDT	Thermal Disc	17"/ø430mm	Unika, Kroma, Levighetor	€ 1.110,00
	KDTFUT	Thermal Disc	17"/ø430mm	Futura, Rocky	€ 1.110,00

CHEMICALS

MARKETING

	DIRECTIONAL WHEELS 360°				
	CA0405	Kit Directional wheels	360°	Levighetor 600-640-645-650, Timba	€ 755,00
	RTO025	Single Sphere		Levighetor 600-640-645-650, Timba	€ 58,00
	CA016101	Directional wheels with gasket		Levighetor 600-640-645-650, Timba	€ 151,00
	CA016501	Gasket without sphere		Levighetor 600-640-645-650, Timba	€ 98,00
	CA32201	Axle for Directional wheels Kit		Levighetor 600-640-645-650, Timba	€ 32,00

PICTURE	CODE	NAME	SIZE	MACHINE	€ each
---------	------	------	------	---------	--------



CARBORUNDUM ø410mm (16").

It is the ideal accessory for levelling cement floors. It eliminates brush marks and surplus materials.

410728	Complete with flange	16"/ø406mm	Single Discs, Levighetor, Timba	€ 230,00
410728FUT	Complete with flange	16"/ø406mm	Futura, Rocky	€ 250,00
410728BEL	Complete with flange	16"/ø406mm	Bella	€ 250,00
410729	Spare part ring	16"/ø406mm		€ 142,00



TYTAN RING VIDIA ø440mm (17,5").

Special vidia discs for quick removal of glue and thick resin coatings and for floor preparation.

430170	Complete with flange	Coarse	Single Discs, Levighetor, Timba	€ 298,00
430170FUT	Complete with flange	Coarse	Futura, Rocky	€ 308,00
430170BEL	Complete with flange	Coarse	Bella	€ 308,00
430180	Spare part ring	Coarse		€ 225,00
430171	Complete with flange	Medium	Single Discs, Levighetor, Timba	€ 298,00
430171FUT	Complete with flange	Medium	Futura, Rocky	€ 308,00
430171BEL	Complete with flange	Medium	Bella	€ 308,00
430181	Spare part ring	Medium		€ 198,00



TYTAN DISK ø430mm (17").

Special tytan discs for quick removal on cement, painted cement, resin floors and on foundations. (To use with Pad Holder SAND PAPER cod.45027).

431112	Tytan Disk ø 430	Fine		€ 139,00
431111	Tytan Disk ø 430	Medium		€ 139,00
431110	Tytan Disk ø 430	Coarse		€ 139,00



BUSH-HAMMER A6 ø430mm (17").

For bush-Hammering, for preparing anti-slip surfaces and to remove thick resin coatings.

45030	Complete Kit	17"/ø430mm	Single Discs	€ 1.325,00
45030FUT	Complete Kit	17"/ø430mm	Futura, Rocky	€ 1.335,00
45030BEL	Complete Kit	17"/ø430mm	Bella	€ 1.335,00
45030	Complete Kit	17"/ø430mm	Levighetor, Timba	€ 1.325,00
45031	Spare part roller			€ 185,00



GROUTING DISC ø430mm (17").

For grouting jointed floors.

45026FUT	Grouting Disc	17"/ø430mm	Futura, Rocky	€ 275,00
45026BEL	Grouting Disc	17"/ø430mm	Bella	€ 275,00
45025	Grouting Disc HD	17"/ø430mm	Levighetor, Timba	€ 275,00
450263	Rubber support	KIT 8 pcs		€ 154,00



LEVELLING DISC.

Levelling disc for fresh concrete.

51025	Complete levelling disc	20"/ø510mm	Single Discs	€ 190,00
51025FUT	Complete levelling disc	20"/ø510mm	Futura, Rocky	€ 190,00
51025BEL	Complete levelling disc	20"/ø510mm	Bella	€ 190,00
51025HD	Complete levelling disc	20"/ø510mm	Levighetor, Timba	€ 245,00
51024	Levelling plate spare part	20"/ø510mm		€ 145,00

GRINDING

SINGLE DISC

TOOLS

SPECIAL

VACUUM

CHEMICALS

MARKETING

GRINDING
SINGLE DISC
TOOLS
SPECIAL
VACUUM
CHEMICALS
MARKETING

PICTURE	CODE	NAME	SIZE	MACHINE	€ each
---------	------	------	------	---------	--------



DUST CONTROL KIT
Includes vacuum, basket, vacuum hood and “y” tube.

AP5701	Dust control complete kit		Series 17”	€ 860,00
AP5801	Dust control complete kit		Series 18”	€ 860,00
AP1201	Dust extractors 315 with basket			€ 610,00
AP2603	Vacuum Hood		Series 17”	€ 495,00
AP5301	Vacuum Hood		Series 18”	€ 495,00



DUST CONTROL KIT

AP6601	Includes vacuum Silurtech, tube and vacuum hood for pad holder.		Levighetor 155, Timba with Pad Holder	€ 860,00
AP6701	Includes vacuum Silurtech, tube and vacuum hood for pad holder.		Levighetor 200 with Pad Holder	€ 860,00
AP6801	Includes vacuum Silurtech, tube and vacuum hood for Planetary with diamond or pavelux.		Levighetor, Timba with Planetary	€ 860,00
AP1201S	Vacuum Silurtech, tube.		Levighetor, Timba, Kroma Sander, Bella Sander, Unika Sander, Futura Sander	€ 795,00



SPLASH GUARD HOOD
Includes vacuum hood and Splash guard.

10101	Splash guard hood		Levighetor 200	€ 250,00
10102	Splash guard hood		Levighetor 155	€ 250,00
AP8401	Bella splash guard		K3, K4 Planetary	€ 68,00



VACUUM HOOD FOR PAD HOLDER
Vacuum hood includes support ring and vacuum guard.

AP2401	Vacuum hood for Pad Holder		Levighetor 200	€ 215,00
AP0201	Vacuum hood for Pad Holder		Levighetor 155, Timba	€ 215,00
AP1902	Vacuum Guard with velcro H 90mm		Levighetor, Timba	€ 68,00
AP022501	Vacuum Guard H 90mm		Levighetor, Timba	€ 98,00
AP1801P	Plastic ring CPL		Levighetor, Timba	€ 155,00



VACUUM HOOD FOR PLANETARY
Vacuum hood includes support ring and vacuum guard.

AP0501NEW	Vacuum hood Planetary (AP1501 + AP2001)		K800W, K1000, K2000, K3, K4	€ 215,00
AP9601	Vacuum hood Planetary		K1200	€ 370,00
AP0501B	Vacuum hood Planetary (AP9401)		K1500	€ 250,00
AP0501C	Vacuum hood Planetary (AP9401)		Planetary with Spring Holder	€ 250,00
AP9701	Vacuum Guard 115X1565mm		K1200	€ 68,00
AP1501	Vacuum Guard 115X1565mm		K1000, K2000, K800W	€ 68,00
AP9501	Vacuum Guard 115X1750mm		K1500	€ 68,00
AP1701	Vacuum Guard 115X1565mm		Planetary with Pavelux or Antike brushes	€ 68,00



THIRD FRONT WHEEL
To reduce the pressure on soft or abrasive floors when the motor couldn't have enough power.

CA010102	Third front Wheel		Levighetor, Timba	€ 195,00
CA11402	Third front Wheel		Levighetor Max, Rafter	€ 295,00

High Quality Floor Pads



* Minimum Order:
5 discs for colour.

	WHITE For polishing.	GREEN For wet stripping on linoleum, rubber.	BLACK For wet Stripping Hard Floor.	RED For Spray Cleaning.	SIZE ø	€
CODE	30041	30042	30043	30045	4" - 100mm	€ 3,90
CODE	30061	30062	30063	30065	6" - 150mm	€ 4,50
CODE	30081	30082	30083	30085	8" - 200mm	€ 4,90
CODE	30091	30092	30093	30095	9,5" - 240mm	€ 5,90
CODE	30111	30112	30113	30115	11" - 280mm	€ 6,50
CODE	30131	30132	30133	30135	13" - 330mm	€ 6,90
CODE	30141	30142	30143	30145	14" - 355mm	€ 8,30
CODE	30161	30162	30163	30165	16" - 406mm	€ 8,70
CODE	30171	30172	30173	30175	17" - 430mm	€ 9,30
CODE	30201	30202	30203	30205	20" - 510mm	€ 13,50
CODE	30211	30212	30213	30215	21" - 530mm	€ 14,50
CODE	30241	30242	30243	30245	24" - 610mm	€ 22,50
CODE	30281	30282	30283	30285	28" - 710mm	€ 28,50



* Minimum Order:
5 discs for colour.



	BROWN For wet and dry cleaning hard floors.	DISCOLUX For High-Speed machines. Specially for use with polishing powder.		SIZE ø	€	SUPERBLACK HD Special abrasive floor pads to clean effectively and to remove concrete milk on industrial floors.
		M43	M56			
CODE	30047	30046A	30046B	4" - 100mm	€ 4,10	30090HD 9,5" - 240mm € 9,00
CODE	30067	30066A	30066B	6" - 150mm	€ 4,90	30113HD 13" - 330mm € 11,00
CODE	30087	30086A	30086B	8" - 200mm	€ 5,50	30173HD 17" - 430mm € 15,00
CODE	30097	30096A	30096B	9,5" - 240mm	€ 6,50	
CODE	30117	30116A	30116B	11" - 280mm	€ 7,50	
CODE	30137	30136A	30136B	13" - 330mm	€ 9,50	
CODE	30147	30146A	30146B	14" - 355mm	€ 9,90	
CODE	30167	30166A	30166B	16" - 406mm	€ 10,50	
CODE	30177	30176A	30176B	17" - 430mm	€ 10,90	
CODE	n.a.	30185A	30185B	19" - 480mm	€ 15,10	
CODE	30207	30206A	30206B	20" - 510mm	€ 15,50	
CODE	30217	30216A	30216B	21" - 530mm	€ 15,90	
CODE	n.a.	30246A	30246B	24" - 610mm	€ 22,50	
CODE	n.a.	30286A	30286B	28" - 710mm	€ 26,50	

GRINDING

SINGLE DISC

TOOLS

SPECIAL

VACUUM

CHEMICALS

MARKETING

Supershine & Spongelux

GRINDING

SINGLE DISC

TOOLS

SPECIAL

VACUUM

CHEMICALS

MARKETING

New and revolutionary diamond discs to restore the gloss on marble floors and terrazzo. Used regularly, they maintain floors always bright as just polished. Easy to use. Use them as a normal "floor pad" disk with mono brush machines or auto-scrubbers. They remove scratches, even deep, clean and polish.

SUPERSHINE PLUS, with semi-rigid support, is recommended with the use of "mono brush machines" to re-polish perfectly and in a short time also very old and worn out floors, getting results comparable to those obtained with the professional Floor Care Machines. They leave a mirror and glide polished surface without "the orange peel effect" which generally leave the competitors diamond abrasive discs on soft support. They remove deep scratches and restore also acid, wine, coca cola or other products stained -floors.

SUPERSHINE SOFT with soft support like "floor pads" is designed for more ordinary use, for glossy recovery and maintenance in large areas with auto-scrubber. Used with normal mono brushes, they can polish also old and worn floors, ensuring an optimal result, not comparable to SUPERSHINE PLUS but higher than similar products which are on the market because they contain more "diamond". SUPERSHINE SOFT can be used WET or DRY SYSTEM! SUPERSHINE SOFT diamond pads can be used on most common floor surfaces such as terrazzo, ceramic tiles, linoleum, vinyl/plastic, natural stone. Transforms a dull, worn floors into clean, glossy and brightly polished floors.

SUPERSHINE PLUS and **SUPERSHINE SOFT** are available in several grains 00, 0, 1, 2 and 3. Generally used grains are 1, 2 and 3 followed by SPONGELUX. If deep or very deep scratches need to be removed it is suggested to start from 0 or 00.

SPONGELUX is a special sponge disc, that is able to wash and polish with only one step. Thanks to its special composition. SpongeLux is the ideal solution for standard maintenance of all type of surfaces since it provides great results and keeps floors shining forever.

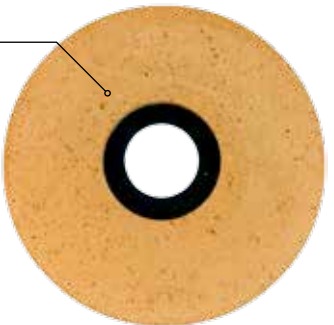
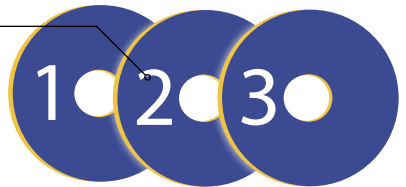
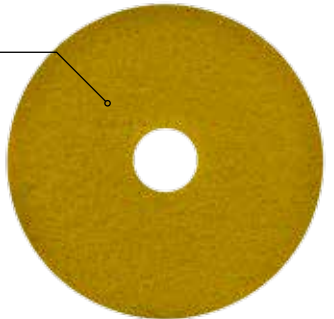
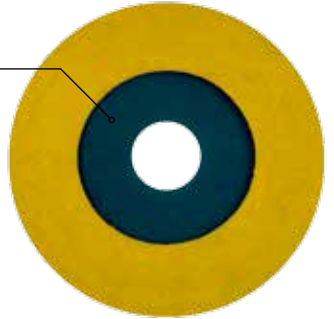

Where can Supershine e Spongelux be used?

- Marble and Terrazzo • Ceramic and Klinker slabs • Natural stone • PVC / Vinyl
- Epoxy resin • Rubber • Wood



SUPERSHINE PLUS

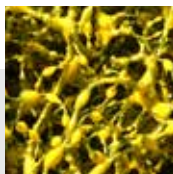

SUPERSHINE SOFT

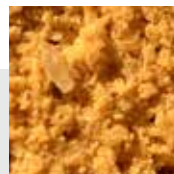

SPONGELUX



Thanks to my magic formula, at once I polish and maintain your floor shiny for ever

3

I remove scratches, I renew and polish your floor thanks to the diamonds



2

1



Efficient, Fast, Bright!

“Supershine & Spongelux” are easy to use!

They are available in the same standard sizes of the Floor Discs normally sold all over the world. They can be applied on any type of floor care machines and auto-scrubbers. Using “Supershine & Spongelux” regularly, instead of the traditional Floor Pads, it allows to restore and maintain the floor shiny forever without changing your normal cleaning routine. The combination of Supershine1, Supershine2 and Supershine3 will allow you to remove scratches. Spongelux, thanks to its magic formula, cleans and polishes marble, terrazzo ecc.. giving it a mirror effect quickly! Regularly used, your floor will remain clean and shiny.

TOOLS

SPECIAL

VACUUM

CHEMICALS

MARKETING



Supershine & Spongelux can be used with any type of mono-brush



Supershine & Spongelux can be used with any type of auto-scrubber



Diamond and Water, respecting the environment



Just add some water!

The use of Spongelux and Supershine discs requires no chemical or wax. Cleaning and polishing are carried out in full respect of the environment. The usage of just water reduces the environmental impact and eliminates the additional costs of chemicals. With Spongelux and Supershine you will soon obtain an amazing clean and brightening floor without using wax, polish or chemical.



BENEFITS

- It cuts costs.
- It improves your performance.
- It increases customer satisfaction.
- Floor is always clean and shining.
- Environmental sustainable cleaning.
- It requires only water.
- It reduces bacteria on floors.

Where others cannot reach

The perfect combination between Klindex machines and Supershine discs allows you to operate where others can't. For example:
 With **Supershine** and **Baby** you can conveniently polish **staircases** and **landings**.
 With **Supershine** and **Vertika** you can rapidly polish **walls**, **counters** and **top**.
 With **Supershine** and **Minielle** you can polish **narrow spaces**.



KlindexDemo

Calling the number **+39 085 859546** it is possible to book a **demonstration** at your headquarters or your working site.

Klindex, always close to its customers!



Supershine & Spongelux PLUS

GRINDING
SINGLE DISC
TOOLS
SPECIAL
VACUUM
CHEMICALS
MARKETING

SuperShine & Spongelux PLUS can be used with any type of single disc.



* Minimum order:

- 1 Kit 4 discs grit: 1-2-3-Spongelux.
- 2 discs of the same grit.

4"/ø100mm SUPERSHINE PLUS

30125K	COMPLETE KIT	€ 43,60
30125	SUPERSHINE PLUS 1	€ 10,90
30126	SUPERSHINE PLUS 2	€ 10,90
30127	SUPERSHINE PLUS 3	€ 10,90
33090	SPONGELUX	€ 13,20

5,5"/ø140mm SUPERSHINE PLUS

30384K	COMPLETE KIT	€ 57,00
30384A	SUPERSHINE PLUS 1	€ 13,50
30385	SUPERSHINE PLUS 2	€ 13,50
30386	SUPERSHINE PLUS 3	€ 13,50
330105	SPONGELUX	€ 16,50

6"/ø150mm SUPERSHINE PLUS

30121K	COMPLETE KIT	€ 69,00
30121	SUPERSHINE PLUS 1	€ 17,50
30122	SUPERSHINE PLUS 2	€ 17,50
30123	SUPERSHINE PLUS 3	€ 17,50
33091	SPONGELUX	€ 22,50

8"/ø200mm SUPERSHINE PLUS

30181K	COMPLETE KIT	€ 138,00
30181	SUPERSHINE PLUS 1	€ 34,50
30182	SUPERSHINE PLUS 2	€ 34,50
30183	SUPERSHINE PLUS 3	€ 34,50
33087	SPONGELUX	€ 49,50

9,5"/ø240mm SUPERSHINE PLUS

30197K	COMPLETE KIT	€ 208,00
30197	SUPERSHINE PLUS 1	€ 49,00
30198	SUPERSHINE PLUS 2	€ 49,00
30199	SUPERSHINE PLUS 3	€ 49,00
30200	SPONGELUX	€ 61,00

11"/ø280mm SUPERSHINE PLUS

30150K	COMPLETE KIT	€ 230,00
30150	SUPERSHINE PLUS 1	€ 57,50
30151	SUPERSHINE PLUS 2	€ 57,50
30152	SUPERSHINE PLUS 3	€ 57,50
33093	SPONGELUX	€ 66,00

13"/ø330mm SUPERSHINE PLUS

30153K	COMPLETE KIT	€ 260,00
30153	SUPERSHINE PLUS 1	€ 66,50
30154	SUPERSHINE PLUS 2	€ 66,50
30155	SUPERSHINE PLUS 3	€ 66,50
33094	SPONGELUX	€ 76,00

16"/ø406mm SUPERSHINE PLUS

30168K	COMPLETE KIT	€ 330,00
30168	SUPERSHINE PLUS 1	€ 83,50
30169	SUPERSHINE PLUS 2	€ 83,50
30170	SUPERSHINE PLUS 3	€ 83,50
33096	SPONGELUX	€ 95,00

17"/ø430mm SUPERSHINE PLUS

30178K	COMPLETE KIT	€ 342,00
30178	SUPERSHINE PLUS 1	€ 87,00
30179	SUPERSHINE PLUS 2	€ 87,00
30180	SUPERSHINE PLUS 3	€ 87,00
33097	SPONGELUX	€ 99,00

18"/ø450mm SUPERSHINE PLUS

30257K	COMPLETE KIT	€ 380,00
30257	SUPERSHINE PLUS 1	€ 93,50
30258	SUPERSHINE PLUS 2	€ 93,50
30259	SUPERSHINE PLUS 3	€ 93,50
33099	SPONGELUX	€ 99,50

20"/ø500mm SUPERSHINE PLUS

30254K	COMPLETE KIT	€ 420,00
30254	SUPERSHINE PLUS 1	€ 106,00
30255	SUPERSHINE PLUS 2	€ 106,00
30256	SUPERSHINE PLUS 3	€ 106,00
30193	SPONGELUX	€ 124,00

21"/ø530mm SUPERSHINE PLUS

n.a.	COMPLETE KIT	no
30251	SUPERSHINE PLUS 1	€ 108,00
30252	SUPERSHINE PLUS 2	€ 108,00
30253	SUPERSHINE PLUS 3	€ 108,00
n.a.	SPONGELUX	no

Supershine & Spongelux SOFT

Supershine & Spongelux SOFT can be used with any type of single disc and auto-scrubber.



- * Minimum order:
- 1 Complete Kit grit 1-2-3-4.
- 2 discs of the same grit.

4"/ø100mm SUPERSHINE SOFT		
30301K	COMPLETE KIT	€ 35,00
30301B	SUPERSHINE SOFT 1	€ 8,90
30302	SUPERSHINE SOFT 2	€ 8,90
30303	SUPERSHINE SOFT 3	€ 8,90
603044	SUPERSHINE SOFT 4	€ 8,90

5,5"/ø140mm SUPERSHINE SOFT		
30490K	COMPLETE KIT	€ 50,00
30490	SUPERSHINE SOFT 1	€ 12,50
30491	SUPERSHINE SOFT 2	€ 12,50
30492	SUPERSHINE SOFT 3	€ 12,50
30493	SUPERSHINE SOFT 4	€ 12,50

6"/ø150mm SUPERSHINE SOFT		
30311K	COMPLETE KIT	€ 56,00
30311	SUPERSHINE SOFT 1	€ 14,20
30312	SUPERSHINE SOFT 2	€ 14,20
30313	SUPERSHINE SOFT 3	€ 14,20
30314	SUPERSHINE SOFT 4	€ 14,20

8"/ø200mm SUPERSHINE SOFT		
30321K	COMPLETE KIT	€ 63,00
30321	SUPERSHINE SOFT 1	€ 15,90
30322	SUPERSHINE SOFT 2	€ 15,90
30323	SUPERSHINE SOFT 3	€ 15,90
30327	SUPERSHINE SOFT 4	€ 15,90

9,5"/ø240mm SUPERSHINE SOFT		
30294K	COMPLETE KIT	€ 76,00
30294	SUPERSHINE SOFT 1	€ 19,00
30295	SUPERSHINE SOFT 2	€ 19,00
30296	SUPERSHINE SOFT 3	€ 19,00
30297	SUPERSHINE SOFT 4	€ 19,00

11"/ø280mm SUPERSHINE SOFT		
30331K	COMPLETE KIT	€ 82,00
30331	SUPERSHINE SOFT 1	€ 20,50
30332	SUPERSHINE SOFT 2	€ 20,50
30333	SUPERSHINE SOFT 3	€ 20,50
30334	SUPERSHINE SOFT 4	€ 20,50

13"/ø330mm SUPERSHINE SOFT		
30341K	COMPLETE KIT	€ 98,00
30341	SUPERSHINE SOFT 1	€ 24,50
30342	SUPERSHINE SOFT 2	€ 24,50
30343	SUPERSHINE SOFT 3	€ 24,50
30344	SUPERSHINE SOFT 4	€ 24,50

16"/ø406mm SUPERSHINE SOFT		
30361K	COMPLETE KIT	€ 134,00
30361	SUPERSHINE SOFT 1	€ 33,50
30362	SUPERSHINE SOFT 2	€ 33,50
30363	SUPERSHINE SOFT 3	€ 33,50
30364	SUPERSHINE SOFT 4	€ 33,50

17"/ø430mm SUPERSHINE SOFT		
30371K	COMPLETE KIT	€ 142,00
30371	SUPERSHINE SOFT 1	€ 35,50
30372	SUPERSHINE SOFT 2	€ 35,50
30373	SUPERSHINE SOFT 3	€ 35,50
30374	SUPERSHINE SOFT 4	€ 35,50

18"/ø450mm SUPERSHINE SOFT		
30194K	COMPLETE KIT	€ 150,00
30194	SUPERSHINE SOFT 1	€ 37,50
30195	SUPERSHINE SOFT 2	€ 37,50
30196	SUPERSHINE SOFT 3	€ 37,50
30197	SUPERSHINE SOFT 4	€ 37,50

20"/ø500mm SUPERSHINE SOFT		
30381K	COMPLETE KIT	€ 158,00
30381	SUPERSHINE SOFT 1	€ 39,50
30382	SUPERSHINE SOFT 2	€ 39,50
30383	SUPERSHINE SOFT 3	€ 39,50
30384	SUPERSHINE SOFT 4	€ 45,50

21"/ø530mm SUPERSHINE SOFT		
30407K	COMPLETE KIT	€ 174,00
30407	SUPERSHINE SOFT 1	€ 43,50
30408	SUPERSHINE SOFT 2	€ 43,50
30409	SUPERSHINE SOFT 3	€ 43,50
30410	SUPERSHINE SOFT 4	€ 43,50

Marble and Terrazzo: polishing with SUPERSHINE PLUS on single discs floor care machine.



- Start grinding the floor with SUPERSHINE PLUS grit 1 or 2 according to the condition of the floor, then proceed with SUPERSHINE PLUS grit 3. It is always suggested to work with little quantity of water for about 60 sec/mq.
- Polish with SPONGELUX working with little quantity of water.

Marble and Terrazzo: polishing with SUPERSHINE SOFT on automatic Scrubber Dryer.



- Start scrubbing the floor with SUPERSHINE SOFT grit 1 or 2 according to the condition of the floors then proceed with SUPERSHINE SOFT grit 3 and 4.
- Maintenance:** use SUPERSHINE SOFT grit 4 with neutral cleaner or Stone SOAP as daily maintenance to keep the floor always glossy.

Linoleum, PVC, Vinyl: floor restoration with high speed single disc machines.



- High speed polishing machine like FUTURA is recommended.
- Start scrubbing the floor with SUPERSHINE SOFT grit 1 or 2 according to the condition of the floor then proceed with SUPERSHINE SOFT grit 3 a. It is always suggested to work with little quantity of water at the medium speed of 200 rpm for about 60 sec/mq
- Polish with SUPERSHINE SOFT grit 4 working with little quantity of water at the higher speed of 400 rpm.
- Maintenance:** buff the floor with SUPERSHINE SOFT grit 4 dry system by High speed buffing machine like Tornado. In alternative it can be used FUTURA at speed of 400 rpm.

Matt finished ceramic, klinker and glazed tiles: heavy duty cleaning (do not use on polished tiles).



- Start scrubbing the floor with SUPERSHINE SOFT grit 2 according to the condition of the floor, work at low speed of 160 rpm. Work wet with little quantity of water until old marks and dirty will disappear.
- Proceed with SUPERSHINE SOFT grit 4. Work with little quantity of water, at low speed.

Old wood coating: floor restoration with high speed single disc machines.



- High speed polishing machine like FUTURA is recommended.
 - Start scrubbing the floor with SUPERSHINE SOFT grit 1 or 2 according the condition of the floor then proceed with SUPERSHINE SOFT grit 3 and 4. Work dry at medium speed of 200 rpm until old marks and imperfection disappear.
 - Polish with SUPERSHINE SOFT grit 4 working at high speed
- Maintenance:** buff the floor with SUPERSHINE SOFT grit 4 dry system by high speed machine.

Old resin and epoxy coated: floor restoration.



- High speed polishing machine like FUTURA is recommended.
 - Start scrubbing the floor with SUPERSHINE SOFT grit 0 or 1 according to the condition of the floor then proceed with SUPERSHINE SOFT grit 2 and 3. It is always suggested to work with little quantity of water at the medium speed of 200 rpm for about 60 sec/mq.
 - Polish with SUPERSHINE SOFT grit 4 working with little quantity of water at the higher speed of 400 rpm.
- Maintenance:** buff the floor with SUPERSHINE SOFT grit 4 dry system by High speed buffing machine like Tornado. In alternative it can be used FUTURA at speed of 400 rpm.

Stone Edges & Skirt: polishing by hand grinder and polishing machines.



- Thanks to the high elasticity and performances and thanks to the various size available, Supershine Soft can be used with any hand grinder and polishing machine to operate in those situations where is not possible to use big machines. Supershine Soft makes easy and fast to polish narrow and difficult areas.
- Start grinding the floor with SUPERSHINE SOFT grit 0 or 1 according to the condition of the floor.
- Proceed with SUPERSHINE SOFT grit 2 and 3.
- Polish with SUPERSHINE SOFT 4. Work with little quantity of water or dry at higher speed.



GRINDING

SINGLE DISC

TOOLS

SPECIAL

VACUUM

CHEMICALS

MARKETING

Planetaries



• Strong gears



• Aluminium frame

• High professional quality

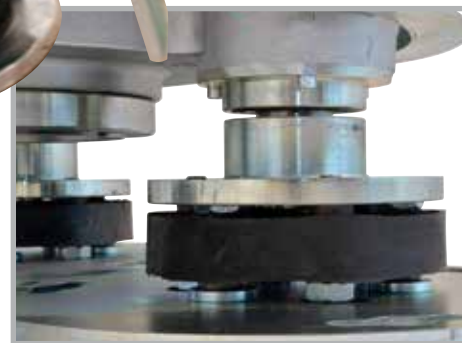

The patented Klindex' Planetary has changed the way of grinding, honing and polishing marble, granite and other natural stone floors. Depending on the way the Planetary is geared, the diamond pads can spin at 800, 1000, 1200 or 2000 RPM. The production has incredibly increased and the result is a more uniform finish at any grit.

GRINDING

SINGLE DISC

TOOLS

SPECIAL

VACUUM

CHEMICALS

MARKETING



SKRAPER
For glue and coating removal.



ANTIKE
For antique finishing.

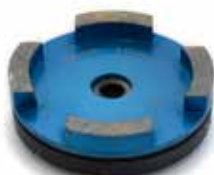

DA
For floor preparation.



CK GREEN
For concrete polishing, wet & dry system.



CARBORUNDUM
To smooth cement foundations.



MS
For grinding marble and terrazzo.



MK
For polishing marble and terrazzo.



GK
For polishing granite.



PAVELUX
To smooth on any abrasive floor.

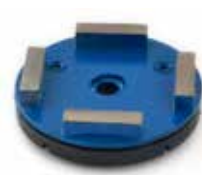

CA
For asphalt and abrasive concretes.

PICTURE	CODE	NAME	SIZE	MACHINE	€ each
---------	------	------	------	---------	--------



Planetary K1000

Ideal to grind and polishing marble, limestone, terracotta, concrete and terrazzo floors.

01000NEWAS	Planetary K1000	17"/ø430mm	Lev. 600, 640	€ 1.545,00
------------	-----------------	------------	---------------	------------



Planetary K1200

The K1200 - very similar to the K1000 but more performance because it can carry tools ø140/146mm di. It has special amortized supports that allow to adapt on the floors.

01200	Planetary K1200	18"/ø450mm	Lev. 600, 645	€ 1.895,00
-------	-----------------	------------	---------------	------------



Planetary K1500

Planetary K1500 fit tools ø8"/200mm or ø3"/75mm. Thank its large working section of ø20"/500mm it grind and polish floors in the fastest way leaving a very planar surface. It has a special amortized support.

01500	Planetary K1500	20"/ø500mm	Lev. 650	€ 2.095,00
-------	-----------------	------------	----------	------------



Planetary K2000

The most suitable Planetary for grinding and polishing granite, porfido and gres porcellain. It multiplies by 11 the rated speed of the machine.

00800WNEW	Planetary K2000	17"/ø430mm	Lev. 600 series	€ 1.895,00
-----------	-----------------	------------	-----------------	------------



Planetary K800 W

The K800W is the Planetary specially designed for sanding wood floors. It leaves the surface perfectly planar and thanks to the integrate vacuum hood to connect to vacuum it works Dust Free.

00800WNEW	Planetary WOODEN	18"/ø450mm	Lev. 155, Timba	€ 1.995,00
-----------	------------------	------------	-----------------	------------



Planetary K800 MAX

Planetary extremely strong and performance. It fits anti-shock system and tools holder 9,5"/ø240mm.

00800MAX	Planetary K800 MAX	21"/ø530mm	Lev. Max	€ 2.950,00
----------	--------------------	------------	----------	------------

GRINDING

SINGLE DISC

TOOLS

SPECIAL

VACUUM

CHEMICALS

MARKETING

EasyKit

The floor solution in a Box!

EASY KIT SUPERCONCRETE

Complete kit for grinding and polishing concrete floors.

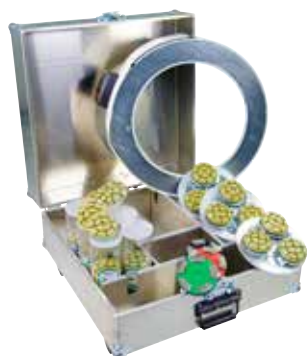

• Levighetor 640



• Levighetor 645

EASY KIT SUPERCONCRETE 4"/ø100mm

EASYKIT640	EASY KIT SUPERCONCRETE		1 pc	€ 3.390,00
100820	DA0 grit40	4"/ø100mm	3 pcs	included
100821	DA1 grit70	4"/ø100mm	3 pcs	included
100822	DA2 grit140	4"/ø100mm	3 pcs	included
075493	Jumper Green 3	3"/ø75mm	9 pcs	included
075494	Jumper Green 4	3"/ø75mm	9 pcs	included
075495	Jumper Green 5	3"/ø75mm	9 pcs	included
075496	Jumper Green 6	3"/ø75mm	9 pcs	included
075497	Jumper Green 7	3"/ø75mm	9 pcs	included
075498	Jumper Green 8	3"/ø75mm	9 pcs	included
AP010801	KIT Spring Holder	4"/ø100mm	1 pc	included

KIT SUPERCONCRETE 5,5"/ø140mm

EASYKIT645	EASY KIT SUPERCONCRETE		1 pc	€ 3.430,00
140820	DA0 grit40	5,5"/ø140mm	3 pcs	included
140821	DA1 grit70	5,5"/ø140mm	3 pcs	included
140822	DA2 grit140	5,5"/ø140mm	3 pcs	included
075493	Jumper Green 3	3"/ø75mm	9 pcs	included
075494	Jumper Green 4	3"/ø75mm	9 pcs	included
075495	Jumper Green 5	3"/ø75mm	9 pcs	included
075496	Jumper Green 6	3"/ø75mm	9 pcs	included
075497	Jumper Green 7	3"/ø75mm	9 pcs	included
075498	Jumper Green 8	3"/ø75mm	9 pcs	included
AP010901	KIT Spring Holder	5,5"/ø140mm	1 pc	included



• Levighetor 650
• Hercules 450-451
• Hercules 550-551
• Expander 530

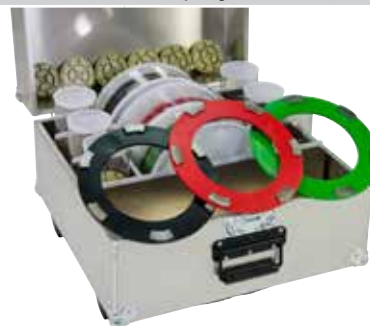

• Expander 1000-850-750-650-580
• Levighetor Max
• Hercules 800-650-601

EASY KIT SUPERCONCRETE 8"/ø200mm

EASYKIT650	EASY KIT SUPERCONCRETE		1 pc	€ 3.050,00
200820	DA0 grit40	8"/ø200mm	3 pcs	included
200821	DA1 grit70	8"/ø200mm	3 pcs	included
200822	DA2 grit140	8"/ø200mm	3 pcs	included
075493	Jumper Green 3	3"/ø75mm	9 pcs	included
075494	Jumper Green 4	3"/ø75mm	9 pcs	included
075495	Jumper Green 5	3"/ø75mm	9 pcs	included
075496	Jumper Green 6	3"/ø75mm	9 pcs	included
075497	Jumper Green 7	3"/ø75mm	9 pcs	included
075498	Jumper Green 8	3"/ø75mm	9 pcs	included

EASY KIT SUPERCONCRETE 9,5"/ø240mm

EASYKITCEXP	EASY KIT SUPERCONCRETE		1 pc	€ 2.980,00
240820	DA0 grit40	9,5"/ø240mm	3 pcs	included
240821	DA1 grit70	9,5"/ø240mm	3 pcs	included
240822	DA2 grit140	9,5"/ø240mm	3 pcs	included
075493	Jumper Green 3	3"/ø75mm	9 pcs	included
075494	Jumper Green 4	3"/ø75mm	9 pcs	included
075495	Jumper Green 5	3"/ø75mm	9 pcs	included
075496	Jumper Green 6	3"/ø75mm	9 pcs	included
075497	Jumper Green 7	3"/ø75mm	9 pcs	included
075498	Jumper Green 8	3"/ø75mm	9 pcs	included

GRINDING

SINGLE DISC

TOOLS

SPECIAL

VACUUM

CHEMICALS

MARKETING

EASY KIT MARBLE

Complete kit for grinding and polishing marble floors.



• Levighetor 640



• Levighetor 645

EASY KIT MARBLE 4"/ø100mm

EASYKITM640	EASY KIT MARBLE		1 pc	€ 2.295,00
100900	MS0	4"/ø100mm	3 pcs	included
100901	MS1	4"/ø100mm	3 pcs	included
100902	MS2	4"/ø100mm	3 pcs	included
100593AS	MCK3	4"/ø100mm	3 pcs	included
100694AS	MK 4	4"/ø100mm	3 pcs	included
100695AS	MK 5	4"/ø100mm	3 pcs	included
100696AS	MK 6	4"/ø100mm	3 pcs	included
100697AS	MK 7	4"/ø100mm	3 pcs	included
00656KG1	Polish KP92	kg 1	1 pc	included
00912R	Hand Pad	grit 120	1 pc	included
00913R	Hand Pad	grit 220	1 pc	included
00914R	Hand Pad	grit 400	1 pc	included
00915R	Hand Pad	grit 800	1 pc	included

EASY KIT MARBLE 5,5"/ø140mm

EASYKITM645	EASY KIT MARBLE		1 pc	€ 2.350,00
140900	MS0	5,5"/ø140mm	3 pcs	included
140901	MS1	5,5"/ø140mm	3 pcs	included
140902	MS2	5,5"/ø140mm	3 pcs	included
140593AS	MCK3	5,5"/ø140mm	3 pcs	included
140694AS	MK 4	5,5"/ø140mm	3 pcs	included
140695AS	MK 5	5,5"/ø140mm	3 pcs	included
140696AS	MK 6	5,5"/ø140mm	3 pcs	included
140697AS	MK 7	5,5"/ø140mm	3 pcs	included
00656KG1	Polish KP92	kg 1	1 pc	included
00912R	Hand Pad	grit 120	1 pc	included
00913R	Hand Pad	grit 220	1 pc	included
00914R	Hand Pad	grit 400	1 pc	included
00915R	Hand Pad	grit 800	1 pc	included



- Levighetor 650
- Hercules 450-451
- Hercules 550-551
- Expander 530



- Expander 1000-850-750-650-580
- Levighetor Max
- Hercules 800-650-601

EASY KIT MARBLE 8"/ø200mm

EASYKITM650	EASY KIT MARBLE		1 pc	€ 2.850,00
200900	MS0	8"/ø200mm	3 pcs	included
200901	MS1	8"/ø200mm	3 pcs	included
200902	MS2	8"/ø200mm	3 pcs	included
075793OR	Jumper Orange 3	3"/ø75mm	9 pcs	included
0750120	Jumper Yellow grit 120	3"/ø75mm	9 pcs	included
0750220	Jumper Yellow grit 220	3"/ø75mm	9 pcs	included
0750400	Jumper Yellow grit 400	3"/ø75mm	9 pcs	included
0750800	Jumper Yellow grit 800	3"/ø75mm	9 pcs	included
00656KG1	Polish KP92	kg 1	1 pc	included
00912R	Hand Pad	grit 120	1 pc	included
00913R	Hand Pad	grit 220	1 pc	included
00914R	Hand Pad	grit 400	1 pc	included
00915R	Hand Pad	grit 800	1 pc	included

EASY KIT MARBLE 9,5"/ø240mm

EASYKITMEXP	EASY KIT MARBLE		1 pc	€ 3.750,00
240900DS12S	MS0	9,5"/ø240mm	3 pcs	included
240901DS12S	MS1	9,5"/ø240mm	3 pcs	included
240902DS12S	MS2	9,5"/ø240mm	3 pcs	included
075793OR	Jumper Orange 3	3"/ø75mm	9 pcs	included
0750120	Jumper Yellow grit 120	3"/ø75mm	9 pcs	included
0750220	Jumper Yellow grit 220	3"/ø75mm	9 pcs	included
0750400	Jumper Yellow grit 400	3"/ø75mm	9 pcs	included
0750800	Jumper Yellow grit 800	3"/ø75mm	9 pcs	included
00656KG1	Polish KP92	kg 1	1 pc	included
00912R	Hand Pad	grit 120	1 pc	included
00913R	Hand Pad	grit 220	1 pc	included
00914R	Hand Pad	grit 400	1 pc	included
00915R	Hand Pad	grit 800	1 pc	included

EASY KIT TERRAZZO FLOORS

Complete kit for grinding and polishing terrazzo and conglomerate floors.



• Levighetor 640



• Levighetor 645

EASY KIT TERRAZZO 4"/ø100mm

EASYKITT640	EASY KIT TERRAZZO		1 pc	€ 1.950,00
100720MTS5S	MTS0	4"/ø100mm	3 pcs	included
100721MTS5S	MTS1	4"/ø100mm	3 pcs	included
100722MTS5S	MTS2	4"/ø100mm	3 pcs	included
100793AS	CK Orange 3	4"/ø100mm	3 pcs	included
100794AS	CK Orange 4	4"/ø100mm	3 pcs	included
100795AS	CK Orange 5	4"/ø100mm	3 pcs	included
100796AS	CK Orange 6	4"/ø100mm	3 pcs	included
100797AS	CK Orange 7	4"/ø100mm	3 pcs	included
000648KG1	Polish Terrazzo	kg 1	1 pc	included
00912R	Hand Pad	grit 120	1 pc	included
00913R	Hand Pad	grit 220	1 pc	included
00914R	Hand Pad	grit 400	1 pc	included
00915R	Hand Pad	grit 800	1 pc	included

EASY KIT TERRAZZO 5,5"/ø140mm

EASYKITT645	EASY KIT TERRAZZO		1 pc	€ 1.950,00
140720TS5S	MTS0	5,5"/ø140mm	3 pcs	included
140721TS5S	MTS1	5,5"/ø140mm	3 pcs	included
140722TS5S	MTS2	5,5"/ø140mm	3 pcs	included
140793AS	CK Orange 3	5,5"/ø140mm	3 pcs	included
140794AS	CK Orange 4	5,5"/ø140mm	3 pcs	included
140795AS	CK Orange 5	5,5"/ø140mm	3 pcs	included
140796AS	CK Orange 6	5,5"/ø140mm	3 pcs	included
140797AS	CK Orange 7	5,5"/ø140mm	3 pcs	included
000648KG1	Polish Terrazzo	kg 1	1 pc	included
00912R	Hand Pad	grit 120	1 pc	included
00913R	Hand Pad	grit 220	1 pc	included
00914R	Hand Pad	grit 400	1 pc	included
00915R	Hand Pad	grit 800	1 pc	included



• Levighetor 650
• Hercules 450-451
• Hercules 550-551
• Expander 530



• Expander 1000-850-750-650-580
• Levighetor Max
• Hercules 800-650-601

EASY KIT TERRAZZO 8"/ø200mm

EASYKITT650	EASY KIT TERRAZZO		1 pc	€ 2.550,00
200720MTS6S	MTS0	8"/ø200mm	3 pcs	included
200721MTS6S	MTS1	8"/ø200mm	3 pcs	included
200722MTS6S	MTS2	8"/ø200mm	3 pcs	included
075793	Jumper Orange 3	3"/ø75mm	9 pcs	included
075794	Jumper Orange 4	3"/ø75mm	9 pcs	included
075795	Jumper Orange 5	3"/ø75mm	9 pcs	included
075796	Jumper Orange 6	3"/ø75mm	9 pcs	included
075797	Jumper Orange 7	3"/ø75mm	9 pcs	included
000648KG1	Polish Terrazzo	kg 1	1 pc	included
00912R	Hand Pad	grit 120	1 pc	included
00913R	Hand Pad	grit 220	1 pc	included
00914R	Hand Pad	grit 400	1 pc	included
00915R	Hand Pad	grit 800	1 pc	included

EASY KIT TERRAZZO 9,5"/ø240mm

EASYKITTEXP	EASY KIT TERRAZZO		1 pc	€ 2.690,00
240720MTS6S	MTS0	9,5"/ø240mm	3 pcs	included
240721MTS6S	MTS1	9,5"/ø240mm	3 pcs	included
240722MTS6S	MTS2	9,5"/ø240mm	3 pcs	included
075793	Jumper Orange 3	3"/ø75mm	9 pcs	included
075794	Jumper Orange 4	3"/ø75mm	9 pcs	included
075795	Jumper Orange 5	3"/ø75mm	9 pcs	included
075796	Jumper Orange 6	3"/ø75mm	9 pcs	included
075797	Jumper Orange 7	3"/ø75mm	9 pcs	included
000648KG1	Polish Terrazzo	kg 1	1 pc	included
00912R	Hand Pad	grit 120	1 pc	included
00913R	Hand Pad	grit 220	1 pc	included
00914R	Hand Pad	grit 400	1 pc	included
00915R	Hand Pad	grit 800	1 pc	included

GRINDING
SINGLE DISC
TOOLS
SPECIAL
VACUUM
CHEMICALS
MARKETING

EASY KIT GRANITE - GRES

Complete kit for grinding and polishing granite and gres floors.



• Levighetor 640



• Levighetor 645

EASY KIT GRANITE - GRES 4"/ø100mm

EASYKITG640	EASY KIT GRANITE - GRES		1 pc	€ 2.850,00
100711	GS1	4"/ø100mm	3 pcs	included
100712	GS2	4"/ø100mm	3 pcs	included
100713	GS3	4"/ø100mm	3 pcs	included
100733	GK Red 3	4"/ø100mm	3 pcs	included
100734	GK Red 4	4"/ø100mm	3 pcs	included
100735	GK Red 5	4"/ø100mm	3 pcs	included
100736	GK Red 6	4"/ø100mm	3 pcs	included
100737	GK Red 7	4"/ø100mm	3 pcs	included
100738	GK Red 8	4"/ø100mm	3 pcs	included
100739	GK Red 9	4"/ø100mm	3 pcs	included
000657KG1	Polish KG	kg 1	1 pc	included
04826TA	Kristal Blu	3,8 l / 1 Gal	1 pc	included
00912R	Hand Pad	grit 120	1 pc	included
00913R	Hand Pad	grit 220	1 pc	included
00914R	Hand Pad	grit 400	1 pc	included
00915R	Hand Pad	grit 800	1 pc	included

EASY KIT GRANITE - GRES 5,5"/ø140mm

EASYKITG645	EASY KIT GRANITE - GRES		1 pc	€ 2.995,00
140711	GS1	5,5"/ø140mm	3 pcs	included
140712	GS2	5,5"/ø140mm	3 pcs	included
140713	GS3	5,5"/ø140mm	3 pcs	included
140733	GK Red 3	5,5"/ø140mm	3 pcs	included
140734	GK Red 4	5,5"/ø140mm	3 pcs	included
140735	GK Red 5	5,5"/ø140mm	3 pcs	included
140736	GK Red 6	5,5"/ø140mm	3 pcs	included
140737	GK Red 7	5,5"/ø140mm	3 pcs	included
140738	GK Red 8	5,5"/ø140mm	3 pcs	included
140739	GK Red 9	5,5"/ø140mm	3 pcs	included
000657KG1	Polish KG	kg 1	1 pc	included
04826TA	Kristal Blu	3,8 l / 1 Gal	1 pc	included
00912R	Hand Pad	grit 120	1 pc	included
00913R	Hand Pad	grit 220	1 pc	included
00914R	Hand Pad	grit 400	1 pc	included
00915R	Hand Pad	grit 800	1 pc	included



- Levighetor 650
- Hercules 450-451
- Hercules 550-551
- Expander 530



- Expander 1000-850-750-650-580
- Levighetor Max
- Hercules 800-650
- Hercules 601

EASY KIT GRANITE - GRES 8"/ø200mm

EASYKITG650	EASY KIT GRANITE - GRES		1 pc	€ 3.350,00
200711GS6S	GS1	8"/ø200mm	3 pcs	included
200712GS6S	GS2	8"/ø200mm	3 pcs	included
200713GS6S	GS3	8"/ø200mm	3 pcs	included
075733	Jumper Red 3	3"/ø75mm	9 pcs	included
075734	Jumper Red 4	3"/ø75mm	9 pcs	included
075735	Jumper Red 5	3"/ø75mm	9 pcs	included
075736	Jumper Red 6	3"/ø75mm	9 pcs	included
075737	Jumper Red 7	3"/ø75mm	9 pcs	included
075738	Jumper Red 8	3"/ø75mm	9 pcs	included
075739	Jumper Red 9	3"/ø75mm	9 pcs	included
000657KG1	Polish KG	kg 1	1 pc	included
04826TA	Kristal Blu	3,8 l / 1 Gal	1 pc	included
00912R	Hand Pad	grit 120	1 pc	included
00913R	Hand Pad	grit 220	1 pc	included
00914R	Hand Pad	grit 400	1 pc	included
00915R	Hand Pad	grit 800	1 pc	included

EASY KIT GRANITE - GRES 9,5"/ø240mm

EASYKITGEXP	EASY KIT GRANITE - GRES		1 pc	€ 3.435,00
240690	GSDA 0 - 6 Segments	9,5"/ø240mm	3 pcs	included
240691	GSDA 1 - 6 Segments	9,5"/ø240mm	3 pcs	included
240692	GSDA 2 - 6 Segments	9,5"/ø240mm	3 pcs	included
075733	Jumper Red 3	3"/ø75mm	9 pcs	included
075734	Jumper Red 4	3"/ø75mm	9 pcs	included
075735	Jumper Red 5	3"/ø75mm	9 pcs	included
075736	Jumper Red 6	3"/ø75mm	9 pcs	included
075737	Jumper Red 7	3"/ø75mm	9 pcs	included
075738	Jumper Red 8	3"/ø75mm	9 pcs	included
075739	Jumper Red 9	3"/ø75mm	9 pcs	included
000657KG1	Polish KG	kg 1	1 pc	included
04826TA	Kristal Blu	3,8 l / 1 Gal	1 pc	included
00912R	Hand Pad	grit 120	1 pc	included
00913R	Hand Pad	grit 220	1 pc	included
00914R	Hand Pad	grit 400	1 pc	included
00915R	Hand Pad	grit 800	1 pc	included

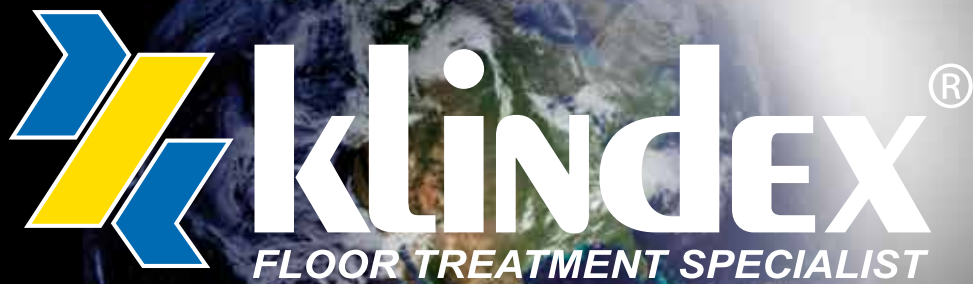

Discover the advantages
of new diamond tools:



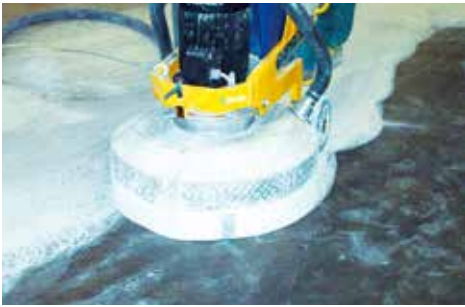

- High quality
- High performance
- Best value

TOOLS FOR GLUE AND COATING REMOVAL



Klindex makes a full range of tools to remove any kind of resin and glue coating. With klindex machines removing coating is very easy!



BT series Diamond tools with round segments designed for effective grinding and removing resin, glue and varnish. Also suitable for concrete grinding.

PICTURE	CODE	NAME	SIZE	MACHINE	€ each
	BT Diamond Tools 4"ø100mm 4 Segments				
	100719BT4S	BT00 grit 30/40	4"ø100mm	Levighetor 640	€ 105,00
	BT Diamond Tools 5,5"ø140mm 4 Segments				
	140719BT4S	BT00 grit 30/40	5,5"ø140mm	Levighetor 645	€ 110,00
	BT Diamond Tools 8"ø200mm 5 Segments				
	200719B5S	BT00 grit 30/40	8"ø200mm	Lev.650, Herc.450-451-550-551, Exp 530	€ 143,00
	BT Diamond Tools 9,5"ø240mm 6 Segments				
	240719BT6S	BT00 grit 30/40	9,5"ø240mm	Exp.1000-850-750-650-580, Lev.Max, Herc.800-650-601	€ 159,00

BT00 ARROW

THIN RESIN/PAINT REMOVAL ON HARD CONCRETE.

Diamond tools with arrow segments with special TCK inserts designed for fast and effective thin resin and paint removal on hard or good substrate cement floors. It does not damage the floor. Not for use on green concrete or abrasive concrete floors.

	BT ARROW TCK Diamond Tools Trapezoid 2 Segments				
	Can only be used with plate tool for trapezoids. Minimum 3 pcs for each plate.				
	70089	BT00 ARROW TCK Anticlockwise	Trapezoid	Universal	€ 56,00
	70089B	BT00 ARROW TCK Clockwise	Trapezoid	Universal	€ 56,00
	BT ARROW TCK Diamond Tools 4"ø100mm				
	70089100	BT00 ARROW	4"ø100mm	Levighetor 640	€ 105,00
	BT ARROW TCK Diamond Tools 5,5"ø140mm				
	70089140	BT00 ARROW	5,5"ø140mm	Levighetor 645	€ 110,00

SKRAPER PCD

TO REMOVE THICK RUBBERY MATERIAL AND THICK COATING ON FLOOR. PCD SKRAPER made up of 1 poly-crystalline diamond and 1 round diamond with TCK insert is suggested to remove all types of hard coatings such as: paint, varnish, glue, epoxy, acrylic, screed residue, mastic, black tar adhesive as well as thick rubbery material. Not for use for conventional grinding or for green concrete. It works fast leaving the surface very rough.

PICTURE	CODE	NAME	SIZE	MACHINE	€ each
---------	------	------	------	---------	--------



SKRAPER PCD Diamond Tools Trapezoid 2 Segments

Can only be used with plate tool for trapezoids. Minimum 3 pcs for each plate.

70090X	SKRAPER PCD Anticlockwise	Trapezoid	Universal	€ 85,00
70090XB	SKRAPER PCD Clockwise	Trapezoid	Universal	€ 85,00



SKRAPER PCD 4''ø100mm

7009100	SKRAPER 100	4''ø100mm	Levighetor 640	€ 136,00
---------	-------------	-----------	----------------	----------



SKRAPER PCD 5,5''ø140mm

7009140	SKRAPER 140	5,5''ø140mm	Levighetor 645	€ 139,00
---------	-------------	-------------	----------------	----------

Super SKRAPER PCD

TO REMOVE THICK RUBBERY MATERIAL AND THICK COATING ON FLOOR. PCD SUPER SKRAPER made up of 2 poly-crystalline diamond and 2 arrow diamond with TCK insert is suggested to remove all types of hard coatings such as: paint, varnish, glue, epoxy, acrylic, screed residue, mastic, black tar adhesive as well as thick rubbery material. Not for use for conventional grinding or for green concrete. Compared to PCD SKRAPER it works less fast but leaves the surface regularly scratched.



SUPER SKRAPER PCD Diamond Tools Trapezoid 2+2 Segments

Can only be used with plate tool for trapezoids. Minimum 3 pcs for each plate.

70092SX	SUPER SKRAPER Anticlockwise	Trapezoid	Universal	€ 139,00
70092SXB	SUPER SKRAPER Clockwise	Trapezoid	Universal	€ 139,00



SUPER SKRAPER PCD Diamond Tools 4''ø100mm

70093100AS	SUPER SKRAPER PCD	4''ø100mm	Levighetor 640	€ 176,00
------------	-------------------	-----------	----------------	----------



SUPER SKRAPER PCD Diamond Tools 5,5''ø140mm

70094140AS	SUPER SKRAPER TRIPLE PCD	5,5''ø140mm	Levighetor 645	€ 395,00
70093140AS	SUPER SKRAPER PCD	5,5''ø140mm	Levighetor 645	€ 176,00

PAD HOLDER FOR TRAPEZOID TOOLS

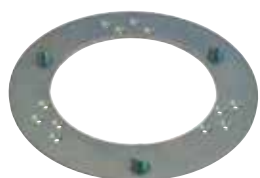

PAD HOLDER FOR TRAPEZOID TOOLS

Pad Holder to use trapezoid tools or diamond butterfly

UT44702	Trapezoid pad holder	8''ø200mm	Lev.650, Herc.450-451-550-551, Exp 530	€ 86,50
PL28003	Trapezoid pad holder	9,5''ø240mm	Exp.1000-850-750-650-580, Lev.Max, Herc.800-650-601	€ 89,00
UT61501	Trapezoid pad holder	13''ø340mm	Expander 950, Hercules 750	€ 94,00

TCK 00

LEVELLING, COATING REMOVAL ON GREEN CONCRETE FLOOR. Very tough and hard bond together with special TCK diamond segments, it provides fast and very durable grinding for soft and abrasive concrete. Fast, efficient heavy duty removal of humps, mastics, thin-set, self-levelling compounds and various light coatings on soft concrete floor. Fast removal of various coatings, levelling and grinding soft and very abrasive concrete. Suitable for green concrete, soft and very abrasive concrete with very long lifetime.

PICTURE	CODE	NAME	SIZE	MACHINE	€ each
---------	------	------	------	---------	--------

TCK Diamond Tools 4"ø100mm



100868	TCK 00S		4"ø100mm	Levighetor 640	€ 155,00
100869	TCK 00		4"ø100mm	Levighetor 640	€ 139,00
100870	TCK 0		4"ø100mm	Levighetor 640	€ 98,00

TCK Diamond Tools 5,5"ø140mm



140868	TCK 00S		5,5"ø140mm	Levighetor 645	€ 189,00
140869	TCK 00		5,5"ø140mm	Levighetor 645	€ 175,00
140870	TCK 0		5,5"ø140mm	Levighetor 645	€ 125,00

TCK Diamond Tools 8"ø200mm 6 Segments



200868	TCK 00S		8"ø200mm	Lev.650, Herc.450-451-550-551, Exp 530	€ 229,00
200869	TCK 00		8"ø200mm	Lev.650, Herc.450-451-550-551, Exp 530	€ 215,00
200870	TCK 0		8"ø200mm	Lev.650, Herc.450-451-550-551, Exp 530	€ 155,00

TCK Diamond Tools 9,5"ø240mm 6 Segments



240288	TCK 00S		9,5"ø240mm	Exp.1000-850-750-650-580, Lev.Max, Herc.800-650-601	€ 239,00
240289	TCK 00		9,5"ø240mm	Exp.1000-850-750-650-580, Lev.Max, Herc.800-650-601	€ 225,00
240290	TCK 0		9,5"ø240mm	Exp.1000-850-750-650-580, Lev.Max, Herc.800-650-601	€ 162,00

TCK Diamond Tools 13,5"ø340mm 6 Segments



340868	TCK 00S		13,5"ø340mm	Expander 950, Hercules 750	€ 259,00
340869	TCK 00		13,5"ø340mm	Expander 950, Hercules 750	€ 245,00
340870	TCK 0		13,5"ø340mm	Expander 950, Hercules 750	€ 182,00



GRINDING

SINGLE DISC

TOOLS

SPECIAL

VACUUM

CHEMICALS

MARKETING

FLOOR PREPARATIONS DIAMOND TOOLS



The concrete floors are different for hardness and abrasion. It is necessary to make a test to choose the right tools. It is suggested to start with DA series. If the consumption of DA is excessive much use CA or CF.

DA series

Diamond tools for medium abrasive concrete.

PICTURE	CODE	NAME	SIZE	MACHINE	€ each
DA Diamond Tools 4"/ø100mm 5 Segments					
	100819	DA00 grit 20	4"/ø100mm	Levighetor 640	€ 125,00
	100820	DA0 grit 40	4"/ø100mm	Levighetor 640	€ 95,00
	100821	DA1 grit 70	4"/ø100mm	Levighetor 640	€ 95,00
	100822	DA2 grit 140	4"/ø100mm	Levighetor 640	€ 95,00
DA Diamond Tools 5,5"/ø140mm 5 Segments					
	140819	DA00 grit 20	5,5"/ø140mm	Levighetor 645	€ 129,00
	140820	DA0 grit 40	5,5"/ø140mm	Levighetor 645	€ 98,00
	140821	DA1 grit 70	5,5"/ø140mm	Levighetor 645	€ 98,00
	140822	DA2 grit 140	5,5"/ø140mm	Levighetor 645	€ 98,00
DA Diamond Tools 8"/ø200mm 6 Segments					
	200819	DA00 grit 20	8"/ø200mm	Lev.650, Herc.450-451-550-551, Exp 530	€ 162,00
	200820	DA0 grit 40	8"/ø200mm	Lev.650, Herc.450-451-550-551, Exp 530	€ 126,00
	200821	DA1 grit 70	8"/ø200mm	Lev.650, Herc.450-451-550-551, Exp 530	€ 126,00
	200822	DA2 grit 140	8"/ø200mm	Lev.650, Herc.450-451-550-551, Exp 530	€ 126,00
DA Diamond Tools 9,5"/ø240mm 6 Segments					
	240819	DA00 grit 20	9,5"/ø240mm	Exp.1000-850-750-650-580, Lev.Max, Herc.800-650-601	€ 165,00
	240820	DA0 grit 40	9,5"/ø240mm	Exp.1000-850-750-650-580, Lev.Max, Herc.800-650-601	€ 135,00
	240821	DA1 grit 70	9,5"/ø240mm	Exp.1000-850-750-650-580, Lev.Max, Herc.800-650-601	€ 135,00
	240822	DA2 grit 140	9,5"/ø240mm	Exp.1000-850-750-650-580, Lev.Max, Herc.800-650-601	€ 135,00
DA Diamond Tools 9,5"/ø240mm 12 Segments					
	240825	DA00 grit 20	9,5"/ø240mm	Exp.1000-850-750-650-580, Lev.Max, Herc.800-650-601	€ 285,00
	240826	DA0 grit 40	9,5"/ø240mm	Exp.1000-850-750-650-580, Lev.Max, Herc.800-650-601	€ 198,00
	240827	DA1 grit 70	9,5"/ø240mm	Exp.1000-850-750-650-580, Lev.Max, Herc.800-650-601	€ 198,00
	240828	DA2 grit 140	9,5"/ø240mm	Exp.1000-850-750-650-580, Lev.Max, Herc.800-650-601	€ 198,00
DA Diamond Tools 13,5"/ø340mm 12 Segments					
	340819DA12SQA	DA00 grit 20	13,5"/ø340mm	Expander 950, Hercules 750	€ 305,00
	340820DA12SQA	DA0 grit 40	13,5"/ø340mm	Expander 950, Hercules 750	€ 218,00
	340821DA12SQA	DA1 grit 70	13,5"/ø340mm	Expander 950, Hercules 750	€ 218,00
	340822DA12SQA	DA2 grit 140	13,5"/ø340mm	Expander 950, Hercules 750	€ 218,00

GRINDING

SINGLE DISC

TOOLS

SPECIAL

VACUUM

CHEMICALS

MARKETING

CD series

Diamond tools for MEDIUM HARD concrete. Not for use on abrasive floors.

PICTURE	CODE	NAME	SIZE	MACHINE	€ each
---------	------	------	------	---------	--------



CD Diamond Tools 4"/ø100mm 4 Segments

100829	CD00 grit 20	4"/ø100mm	Levighetor 640	€ 108,00
100830	CD0 grit 40	4"/ø100mm	Levighetor 640	€ 96,00
100831	CD1 grit 70	4"/ø100mm	Levighetor 640	€ 93,00
100832	CD2 grit 140	4"/ø100mm	Levighetor 640	€ 92,00



CD Diamond Tools 5,5"/ø140mm 4 Segments

140829	CD00 grit 20	5,5"/ø140mm	Levighetor 645	€ 118,00
140830	CD0 grit 40	5,5"/ø140mm	Levighetor 645	€ 99,00
140831	CD1 grit 70	5,5"/ø140mm	Levighetor 645	€ 96,00
140832	CD2 grit 140	5,5"/ø140mm	Levighetor 645	€ 95,00



CD Diamond Tools 8"/ø200mm 4 Segments

200829	CD00 grit 20	8"/ø200mm	Lev.650, Herc.450-451-550-551, Exp 530	€ 142,00
200830	CD0 grit 40	8"/ø200mm	Lev.650, Herc.450-451-550-551, Exp 530	€ 129,00
200831	CD1 grit 70	8"/ø200mm	Lev.650, Herc.450-451-550-551, Exp 530	€ 119,00
200832	CD2 grit 140	8"/ø200mm	Lev.650, Herc.450-451-550-551, Exp 530	€ 119,00



CD Diamond Tools 9,5"/ø240mm 4 Segments

240829CD4SQA	CD00 grit 20	9,5"/ø240mm	Exp.1000-850-750-650-580, Lev.Max, Herc.800-650-601	€ 142,00
240830CD4SQA	CD0 grit 40	9,5"/ø240mm	Exp.1000-850-750-650-580, Lev.Max, Herc.800-650-601	€ 129,00
240831CD4SQA	CD1 grit 70	9,5"/ø240mm	Exp.1000-850-750-650-580, Lev.Max, Herc.800-650-601	€ 119,00
240832CD4SQA	CD2 grit 140	9,5"/ø240mm	Exp.1000-850-750-650-580, Lev.Max, Herc.800-650-601	€ 119,00



CD Diamond Tools 9,5"/ø240mm 6 Segments

240829	CD00 grit 20	9,5"/ø240mm	Exp.1000-850-750-650-580, Lev.Max, Herc.800-650-601	€ 179,00
240830	CD0 grit 40	9,5"/ø240mm	Exp.1000-850-750-650-580, Lev.Max, Herc.800-650-601	€ 159,00
240831	CD1 grit 70	9,5"/ø240mm	Exp.1000-850-750-650-580, Lev.Max, Herc.800-650-601	€ 149,00
240832	CD2 grit 140	9,5"/ø240mm	Exp.1000-850-750-650-580, Lev.Max, Herc.800-650-601	€ 149,00



CD Diamond Tools 13,5"/ø340mm 6 Segments

340829	CD00 grit 20	13,5"/ø340mm	Expander 950, Hercules 750	€ 199,00
340830	CD0 grit 40	13,5"/ø340mm	Expander 950, Hercules 750	€ 179,00
340831	CD1 grit 70	13,5"/ø340mm	Expander 950, Hercules 750	€ 169,00
240832	CD2 grit 140	13,5"/ø340mm	Expander 950, Hercules 750	€ 169,00



GRINDING

SINGLE DISC

TOOLS

SPECIAL

VACUUM

CHEMICALS

MARKETING

CA series

Diamond tools for abrasive concrete.

GRINDING

PICTURE	CODE	NAME	SIZE	MACHINE	€ each
CA Diamond Tools 4"/ø100mm 4 Segments					
	100839CA4SAS	CA00 grit 20	4"/ø100mm	Levighetor 640	€ 128,00
	100840CA4SAS	CA0 grit 40	4"/ø100mm	Levighetor 640	€ 121,00
	100841CA4SAS	CA1 grit 70	4"/ø100mm	Levighetor 640	€ 98,00
	100842CA4AS	CA2 grit 140	4"/ø100mm	Levighetor 640	€ 98,00

SINGLE DISC

CA Diamond Tools 5,5"/ø140mm 4 Segments					
	140839CA4SAS	CA00 grit 20	5,5"/ø140mm	Levighetor 645	€ 135,00
	140840CA4SAS	CA0 grit 40	5,5"/ø140mm	Levighetor 645	€ 127,00
	140841CA4SAS	CA1 grit 70	5,5"/ø140mm	Levighetor 645	€ 115,00
	140842CA4SAS	CA2 grit 140	5,5"/ø140mm	Levighetor 645	€ 105,00

TOOLS

CA Diamond Tools 8"/ø200mm 4 Segments					
	200839CA4SQA	CA00 grit 20	8"/ø200mm	Lev.650, Herc.450-451-550-551, Exp 530	€ 155,00
	200840CA4SQA	CA0 grit 40	8"/ø200mm	Lev.650, Herc.450-451-550-551, Exp 530	€ 149,00
	200841CA4SQA	CA1 grit 70	8"/ø200mm	Lev.650, Herc.450-451-550-551, Exp 530	€ 143,00
	200842CA4SQA	CA2 grit 140	8"/ø200mm	Lev.650, Herc.450-451-550-551, Exp 530	€ 135,00

SPECIAL

CA Diamond Tools 8"/ø200mm 6 Segments					
	200839CA6S	CA00 grit 20	8"/ø200mm	Lev.650, Herc.450-451-550-551, Exp 530	€ 195,00
	200840CA6S	CA0 grit 40	8"/ø200mm	Lev.650, Herc.450-451-550-551, Exp 530	€ 185,00
	200841CA6S	CA1 grit 70	8"/ø200mm	Lev.650, Herc.450-451-550-551, Exp 530	€ 175,00
	200842CA6S	CA2 grit 140	8"/ø200mm	Lev.650, Herc.450-451-550-551, Exp 530	€ 161,00

VACUUM

CA Diamond Tools 9,5"/ø240mm 6 Segments					
	240839CA6S	CA00 grit 20	9,5"/ø240mm	Exp.1000-850-750-650-580, Lev.Max, Herc.800-650-601	€ 210,00
	240840CA6S	CA0 grit 40	9,5"/ø240mm	Exp.1000-850-750-650-580, Lev.Max, Herc.800-650-601	€ 192,00
	240841CA6S	CA1 grit 70	9,5"/ø240mm	Exp.1000-850-750-650-580, Lev.Max, Herc.800-650-601	€ 179,00
	240842CA6S	CA2 grit 140	9,5"/ø240mm	Exp.1000-850-750-650-580, Lev.Max, Herc.800-650-601	€ 162,00

CHEMICALS

CA Diamond Tools 9,5"/ø240mm 12 Segments					
	240839CA12S	CA00 grit 20	9,5"/ø240mm	Exp.1000-850-750-650-580, Lev.Max, Herc.800-650-601	€ 326,00
	240840CA12S	CA0 grit 40	9,5"/ø240mm	Exp.1000-850-750-650-580, Lev.Max, Herc.800-650-601	€ 299,00
	240841CA12S	CA1 grit 70	9,5"/ø240mm	Exp.1000-850-750-650-580, Lev.Max, Herc.800-650-601	€ 279,00
	240842CA12S	CA2 grit 140	9,5"/ø240mm	Exp.1000-850-750-650-580, Lev.Max, Herc.800-650-601	€ 279,00

MARKETING

CA Diamond Tools 13,5"/ø340mm 12 Segments					
	340839CA12S	CA00 grit 20	13,5"/ø340mm	Expander 950, Hercules 750	€ 346,00
	340840CA12S	CA0 grit 40	13,5"/ø340mm	Expander 950, Hercules 750	€ 319,00
	340841CA12S	CA1 grit 70	13,5"/ø340mm	Expander 950, Hercules 750	€ 299,00
	340842CA12S	CA2 grit 140	13,5"/ø340mm	Expander 950, Hercules 750	€ 299,00

CF series

Diamond tools for asphalt and very abrasive concrete.

PICTURE	CODE	NAME	SIZE	MACHINE	€ each
---------	------	------	------	---------	--------



CF Diamond Tools 5"/ø100mm 4 Segments

100859CF4S	CF00 grit 20	4"/ø100mm	Levighetor 640	€ 139,00
100860CF4S	CF0 grit 40	4"/ø100mm	Levighetor 640	€ 129,00



CF Diamond Tools 5,5"/ø140mm 4 Segments

140859CF4SAS	CF00 grit 20	5,5"/ø140mm	Levighetor 645	€ 141,00
140860CF4SAS	CF0 grit 40	5,5"/ø140mm	Levighetor 645	€ 135,00



CF Diamond Tools 8"/ø200mm 4 Segments

200859CF4SQA	CF00 grit 20	8"/ø200mm	Lev.650, Herc.450-451-550-551, Exp 530	€ 169,00
200860CF4SQA	CF0 grit 40	8"/ø200mm	Lev.650, Herc.450-451-550-551, Exp 530	€ 153,00



CF Diamond Tools 8"/ø200mm 6 Segments

200859CF6S	CF00 grit 20	8"/ø200mm	Lev.650, Herc.450-451-550-551, Exp 530	€ 215,00
200860CF6S	CF0 grit 40	8"/ø200mm	Lev.650, Herc.450-451-550-551, Exp 530	€ 195,00



CF Diamond Tools 9,5"/ø240mm 6 Segments

240859CF6S	CF00 grit 20	9,5"/ø240mm	Exp.1000-850-750-650-580, Lev.Max, Herc.800-650-601	€ 225,00
240860CF6S	CF0 grit 40	9,5"/ø240mm	Exp.1000-850-750-650-580, Lev.Max, Herc.800-650-601	€ 205,00



CF Diamond Tools 9,5"/ø240mm 12 Segments

240865CF12S	CF00 grit 20	9,5"/ø240mm	Exp.1000-850-750-650-580, Lev.Max, Herc.800-650-601	€ 375,00
240866CF12S	CF0 grit 40	9,5"/ø240mm	Exp.1000-850-750-650-580, Lev.Max, Herc.800-650-601	€ 340,00



CF Diamond Tools 13,4"/ø340mm 12 Segments

340865CF12S	CF00 grit 20	13,4"/ø340mm	Expander 950, Hercules 750	€ 395,00
340866CF12S	CF0 grit 40	13,4"/ø340mm	Expander 950, Hercules 750	€ 360,00

GRINDING

SINGLE DISC

TOOLS

SPECIAL

VACUUM

CHEMICALS

MARKETING

BUSH HAMMER



BUSH HAMMER is an exclusive special tool designed by Klindex for many applications: -to make safety anti-slip surfaces on marble, granite and natural stones. • To remove glue, varnish and resin coating. • To break-down thick coating difficult to remove with normal diamond tools. • To create "face-see effect "on precast panels". • To scarify any kind of surface. • To create orange-peel skin on any surface. • For floor preparation. Using Bush Hammer, in combination with Diamond Tools, it is possible to prepare in the best way the surface in order to apply correctly the new coating.

PICTURE	CODE	NAME	SIZE	MACHINE	€ each
---------	------	------	------	---------	--------



Bush-Hammer 16"/ø406mm

Complete of 6 Roller Tolls.

45030	Bush Hammer	16"/ø406mm	Levighetor and Single Disc	€ 1.325,00
45031	Spare part roller	Standard Spike		€ 185,00



Bush-Hammer 5,5"/ø140mm

UT2302K1000PS	Bush Hammer 140	5,5"/ø140mm	Levighetor 640, 645	€ 630,00
45031	Spare part roller	Standard Spike		€ 185,00



Bush-Hammer 8"/ø200mm

UT011701QA	Bush Hammer 200	8"/ø200mm	Lev.650, Herc.450-451-550-551, Exp 530	€ 830,00
45031	Spare part roller	Standard Spike	Lev.650, Herc.450-451-550-551, Exp 530	€ 185,00



Bush-Hammer 9,5"/ø240mm

UT022402	Bush Hammer 240	9,5"/ø240mm	Exp.1000-850-750-650-580, Lev.Max, Herc.800-650-601	€ 1.095,00
UT021101	Roller with bearing	Standard Spike	Exp.1000-850-750-650-580, Lev.Max, Herc.800-650-601	€ 295,00
UT082601	Roller without bearing	Standard Spike	Exp.1000-850-750-650-580, Lev.Max, Herc.800-650-601	€ 159,00



Sandblasting 9,5"/ø240mm "EFFECT OF GRAIN"

UT014749	Sandblasting 240	9,5"/ø240mm	Exp.1000-850-750-650-580, Lev.Max, Herc.800-650-601	€ 835,00
UT014804	Roller with bearing	Standard Spike	Exp.1000-850-750-650-580, Lev.Max, Herc.800-650-601	€ 175,00



Antiko 60

Water-oil-repellent satin effect for interior floors.

00619Box	Antiko 60	12 x 1 l	Solvent Based	€ 201,00
00619WB	Antiko 60	5 l	Water Based	€ 172,00

GRINDING

SINGLE DISC

TOOLS

SPECIAL

VACUUM

CHEMICALS

MARKETING







Superconcrete System

Superconcrete System

► Transform your concrete floor!

- *Thanks to the continuous research of new technologies for surface treatments, the KLINDEX Team has developed a new technique called SUPERCONCRETE that allows you to transform any old, ugly, stained or dusty concrete floor in a perfectly smooth surface, extremely resistant, shiny, incredibly beautiful, easy to keep clean and free of dust. Applying the SUPERCONCRETE technique on a new floor it is possible to obtain unimaginable results and comparable for aesthetics and resistance to a marble or a terrazzo floor. It is also possible to create designs and logos allowing your imagination to realize priceless artworks.*

Benefits:

- **Easy to clean** since the surface has become smooth and not rough anymore.
- There is **no more dust** since the dusty outward part of the floor has been removed.
- **Resistant to traffic.** Particularly suitable for forklift truck traffic that will not leave black tyre marks on the floor and will always have an excellent grip.
- **Resistant to external agents** since it is consolidated and waterproofed.
- **It does not "scratch"**. No unsightly streaks appear like on the floors covered with resins or paints. The surface is smooth and it is not covered by waxes, resins or filming products which can get scratched.
- **Hygienic.** The smooth surface, hardened and polished, does not absorb and so it is easier to remove germs and bacteria.
- **Economical.** To transform an old floor in an aesthetically beautiful new floor, it's cheaper than any other solution. Also a polished floor compared to a rough cement floor allows considerable savings on maintenance costs, since the operating machines find less resistance and so less wear of the brushes, discs, wheels, mop, etc.
- **Dyeable.** Is it possible to add an artistic touch by coloring with impregnation colors called BETON COLOR DYE. The BETON COLOR DYE unlike paints or resins systems "do not cover the surface", do not create a film but they go in depth reacting with the "cement salts". So they do not scratch or peel like the paints and do not come off or don't make bubbles like resins.
- **Ecological.** The floor is sanded and polished without application of resins, paints or other products potentially harmful and carcinogenic. There will not be over time migrate odours and volatilization in the air of microparticles that may cause allergies or health hazardous.





The advantages:

- Dust proof. • Durable surface. • Aesthetically pleasing. • Resistant to heavy traffic and forklifts. • Easy to clean. • Resistant to external agents. • Highly hygienic environment in the workplace. • Possibility to colour.

The technique in a few words:

- Concrete polishing • Elimination of height variances. Consolidation of concrete with a special hardener. • This process causes a chemical reaction resulting in the hardening of the concrete. • Polishing to obtain a high finish, shine and brilliance of the floor when cleaning, you can perform cleanup operations with a reduced consumption of chemical products.

Applications:

- Retail shops. • Logistics centres. • Garage. • Commercial areas and offices. • Production areas. • A modern environment. • Warehouses. • Parking. • Offices. • Airports. • Schools. • Showroom. • Galleries. • Museums. • Discos. • Pub.



The pavement is very resistant to the passage of heavy vehicles.



Make your logo brilliant.



Water and Oil repellent.



This kind of surface is very appreciated in workplaces

4 NEW METHODS FOR POLISHING THE CONCRETE FLOORS

SuperConcrete is a polishing system for concrete developed by Klindex which turns every type of cement into a smooth, highly resistant and incredible beautiful glossy surface. With the SuperConcrete system even an old, stained and worn floor can be polished to make it look like new, extremely resistant, repellent to dirt, and easy to clean. With very few steps you will be able to polish, make waterproof, create logos, getting a nice surface like marble and strong as concrete. The SuperConcrete system offers different procedures to achieve different finishes: SUPERCONCRETE PREMIUM, FAST, HS e SUPERCONCRETE TERRAZZO EFFECT.

GRINDING

SINGLE DISC

TOOLS

SPECIAL

VACUUM

CHEMICALS

MARKETING



SuperConcrete PREMIUM

The system for mirror polishing of the concrete surfaces for excellence

- High planarity of the floor
- Mirror polishing
- Stain Resistant
- Hi-tech Look
- Wide range of colours available



SuperConcrete FAST

The fastest way to turn a normal concrete floor, new or old into a shiny, hard and resistant surface.

By using the latest technology for concrete grinding and polishing one can achieve very good results while saving time, effort and money.



SuperConcrete HS

With the high-speed machine HURRIKANE and the new diamond discs KING CONC, to turn an industrial floated floor into a beautiful surface, durable, stain-resistant, glossy and easy-to-clean floor has become very easy. It is possible to polish up to 400-500 square meters per day!!



SuperConcrete TERRAZZO EFFECT

- Full exposure aggregates
- High planarity and regularity of the floor
- Variety of colour options
- Contemporary look

Before

After



GRINDING

SINGLE DISC

TOOLS

SPECIAL

VACUUM

CHEMICALS

MARKETING

DIAMOND TOOLS FOR CONCRETE POLISHING

Spring Holder System

The Spring Holder System, to be used with 9 pcs of $\varnothing 3''/75\text{mm}$ diamond discs, is a special device developed for grinding and polishing concrete floors. Thanks to the smart design, installed on the grinding machine, it allows to achieve a perfect and homogeneous result, even if the floor is not perfectly flat. This is possible because these discs are pushed by the springs through the small depression that may be present in the floor.

PICTURE	CODE	NAME	SIZE	MACHINE	€ each
	Kit SPRING HOLDER SYSTEM (kit 3 pcs) The art. "AP010803" and "AP010904" include Vacuum Hood.				
	AP010803	Spring Holder System	4'' \varnothing 100mm	Lev.640	€ 750,00
	AP010904	Spring Holder System	5,5'' \varnothing 140mm	Lev.645	€ 750,00
	AP011004	Spring Holder System	8'' \varnothing 200mm	Lev.650, Herc.450-451-550-551, Exp 530	€ 560,00
	AP011101	Spring Holder System	9,5'' \varnothing 240mm	Exp.1000-850-750-650-580, Lev.Max, Herc.800-650-601	€ 560,00

JUMPER GREEN series

Diamond resin discs manufactured WITH RAISED SEGMENTS for longer life and a better finish for polished concrete. Can be used WET & DRY.

Jumper Green Diamond Tools 3'' \varnothing 75mm

	075493	Jumper Green 3	3'' \varnothing 75mm	Lev.,Hercules,Lev.Max,Expander	€ 19,50
	075494	Jumper Green 4	3'' \varnothing 75mm	Lev.,Hercules,Lev.Max,Expander	€ 19,50
	075495	Jumper Green 5	3'' \varnothing 75mm	Lev.,Hercules,Lev.Max,Expander	€ 19,50
	075496	Jumper Green 6	3'' \varnothing 75mm	Lev.,Hercules,Lev.Max,Expander	€ 19,50
	075497	Jumper Green 7	3'' \varnothing 75mm	Lev.,Hercules,Lev.Max,Expander	€ 19,50
	075498	Jumper Green 8	3'' \varnothing 75mm	Lev.,Hercules,Lev.Max,Expander	€ 19,50

Jumper Green Diamond Tools 4'' \varnothing 100mm

	100493	Jumper Green 3	4'' \varnothing 100mm	Lev.,Hercules,Lev.Max,Expander	€ 29,90
	100494	Jumper Green 4	4'' \varnothing 100mm	Lev.,Hercules,Lev.Max,Expander	€ 29,90
	100495	Jumper Green 5	4'' \varnothing 100mm	Lev.,Hercules,Lev.Max,Expander	€ 29,90
	100496	Jumper Green 6	4'' \varnothing 100mm	Lev.,Hercules,Lev.Max,Expander	€ 29,90
	100497	Jumper Green 7	4'' \varnothing 100mm	Lev.,Hercules,Lev.Max,Expander	€ 29,90
	100498	Jumper Green 8	4'' \varnothing 100mm	Lev.,Hercules,Lev.Max,Expander	€ 29,90

CR Series Diamond Discs for SUPERCONCRETE FAST

Diamond discs with a mix of sectors hybrid resin, ceramic and metal to smooth concrete floors using the Fast super concrete system. The CR2 is used for grouting with Concrete Filler.

CR Diamond Tools 5,5'' \varnothing 140mm

	140CR1	CR1	5,5'' \varnothing 140mm	Levighetor 645	€ 95,00
	140CR2	CR2	5,5'' \varnothing 140mm	Levighetor 645	€ 95,00
	140CR3	CR3	5,5'' \varnothing 140mm	Levighetor 645	€ 95,00
	140CR4	CR4	5,5'' \varnothing 140mm	Levighetor 645	€ 95,00

CR Diamond Tools 8'' \varnothing 200mm

	200CR1	CR1	8'' \varnothing 200mm	Lev.650, Herc.450-451-550-551, Exp 530	€ 135,00
	200CR2	CR2	8'' \varnothing 200mm	Lev.650, Herc.450-451-550-551, Exp 530	€ 135,00
	200CR3	CR3	8'' \varnothing 200mm	Lev.650, Herc.450-451-550-551, Exp 530	€ 135,00
	200CR4	CR4	8'' \varnothing 200mm	Lev.650, Herc.450-451-550-551, Exp 530	€ 135,00

CR Diamond Tools 9,5'' \varnothing 240mm

	240CR1	CR1	9,5'' \varnothing 240mm	Exp.1000-850-750-650-580, Lev.Max, Herc.800-650-601	€ 175,00
	240CR2	CR2	9,5'' \varnothing 240mm	Exp.1000-850-750-650-580, Lev.Max, Herc.800-650-601	€ 175,00
	240CR3	CR3	9,5'' \varnothing 240mm	Exp.1000-850-750-650-580, Lev.Max, Herc.800-650-601	€ 115,00
	240CR4	CR4	9,5'' \varnothing 240mm	Exp.1000-850-750-650-580, Lev.Max, Herc.800-650-601	€ 115,00

PICTURE	CODE	NAME	SIZE	TYPE	€ each
---------	------	------	------	------	--------

GRINDING

SINGLE DISC

TOOLS

SPECIAL

VACUUM

CHEMICALS

MARKETING



BETON HARDENER

Beton Hardener is a special product to improve the hardness and quality of new and old concrete floors. Excellent also for Terrazzo and any agglomerate floor. It reacts with the salt of cement increasing the hardness and resistance to the abrasion and protecting against oils, greases and other agents contaminating.

04820	Beton Hardener K10	5 l	SODIUM-POTASSIUM	€ 52,00
04820LT25	Beton Hardener K10	25 Lt	SODIUM-POTASSIUM	€ 225,00
04818	Beton Hardener K35	25 Lt	SODIUM-POTASSIUM	€ 168,00
04824LT5	Beton Hardener Lithium Pro 604	5 l	LITHIUM	€ 95,00
04824LT25	Beton Hardener Lithium Pro 604	25 l	LITHIUM	€ 395,00
04824CUBO	Beton Hardener Lithium Pro 604	1000 Lt	Lithium	€ 15.250,00



BETON SKUDO

Penetrating stain repellent for polished concrete. It penetrates into the surfaces giving to the floor a high resistance to many external agent.

00606	Beton Skudo	4 l		€ 72,00
00606Box	Beton Skudo	4 x 4 l		€ 275,00



BETON GUARD LITHIUM PRO

Oil-repellent Once applied it makes a hard film for maximum protection. It can be applied directly but we suggest polishing with high speed machines such as HURRIKANE. Just like any "film-forming product" it requires maintenance with high speed machines to remove scratches and streaks.

00611PLUSLI	Beton Guard Lithium Pro	5 l	Ready to use	€ 168,00
00610PLUSLI	Beton Guard Lithium Pro	25 l	Ready to use	€ 775,00



BETON GUARD LITHIUM

Oil-repellent Once applied it makes a very hard film for maximum protection. It can be applied directly but we suggest polishing with high speed machines such as HURRIKANE. Just like any "film-forming product" it requires maintenance with high speed machines to remove scratches and streaks. Very appreciated in airports, shopping malls and in large areas subject to high traffic of people.

00620	Beton Guard Lithium	5 l	Ready to use	€ 280,00
04823	Beton Guard Lithium	25 l	Ready to use	€ 1.275,00



LITHIUM IMPROVE

Lithium Improve is a special product developed by Klindex to improve the quality and the performance of Beton Guard Lithium.

048281	Lithium Improve	1 l		€ 22,00
048285	Lithium Improve	5 l		€ 99,80



STONE SOAP

For protecting and maintenance care of polished concrete. Improve and protect surface day by day.

00604LT5	Stone Soap	5 l		€ 75,00
00604Box	Stone Soap	3 x 5 l		€ 208,00



BETON FILLER

BETON FILLER is a product developed for grouting and filling up small holes and superficial cracks of the concrete floor. Fast to use because it is applied with grinding machine fitted with diamond disc CR2. Mixed with the dust created during the grinding operation it will get the same colour of the surface. It is compatible with Beton Colour Dye.

00613	Beton Filler	1 l	Concentrated dilute max 10%	€ 27,50
-------	--------------	-----	-----------------------------	---------

GRINDING

PICTURE	CODE	NAME	SIZE	TYPE	€ each
---------	------	------	------	------	--------



BETON GROUT & CRACK REPAIR

Beton Grout is Klindex' system developed to fix very damaged concrete floors, to close large holes and deep cracks. The system is composed by three products: BETON GROUT CATALYZER, BETON GROUT RESIN and micro spheres BETON GROUT GLASS BUBBLES. The main features of BETON GROUT SYSTEM are:

- a) The micro spheres keep the product soft and malleable, and allow to fill perfectly the area to repair.
- b) The resin is "expansive" permitting the subsequent grinding and polishing.

00635	Beton Grout Catalyzer	1 kg		€ 62,00
00636	Beton Grout Resin	1 kg		€ 62,00
00637	Beton Grout Bubbles	1 kg		€ 42,00

SINGLE DISC



EPO GROUT

EpogROUT system to fill up concrete surface. **Instruction to use:** a) Mix the two components (A+B) very well. b) Apply the product as normally applies a filler in order to close the porosity. 5 Kg of the product can cover 25-40 m²/q according the porosity of the surface c) Proceed spreading the Mineral C on the surface treated with EpogROUT A+B. 20 Kg cover about 25-40 m²/q according the porosity of the surface d) Grind the surface with Jumper Inox for reacting Mineral C with EpogROUT and to fill up the porosity. Do not use on floors with humidity problems and/or saltpetre efflorescence.

00639	Epo Grout A+B	5 kg - (A 3,55 Kg + B 1,45 Kg)		€ 164,00
00640	Mineral C	25 kg		€ 24,00
0756INOX	Jumper Inox			€ 42,50

TOOLS



SLURRY DRYER

Solidifier for concrete and natural stones sludges

Slurry Dryer solidifies slurry and sludges into a NON DANGEROUS gel-like condition, easy to collect and to handle without producing dust. **Use:** • Concrete grinding and polishing • Concrete and stones saw cutting and drilling • Concrete areas to rinse (ex. Concrete mixers) • Stone restoration

04117	Slurry Dryer	20 Kg		€ 304,00
-------	--------------	-------	--	----------

SPECIAL



SPRAYER

Professional low-pressure sprayer to apply the beton colour.

00695	Sprayer	1,5 l		€ 20,50
00697	Sprayer	15 l		€ 190,00

VACUUM



TOOLS AND CLOTHS

04231	Microfiber cloth	50x22mm		€ 12,90
1000550	Microfiber cloths tool	50x22mm		€ 43,50
2000303	Antistatic cloth	60X22mm		€ 79,00
1100404	Antistatic cloth tool	60X22mm		€ 36,50

CHEMICALS



MICROFIBER DISC

04230	Microfiber Disc	17"/ø430mm	Mon.17"	€ 15,50
04229	Microfiber Disc	9,5"/ø240mm	Lev.Max, Expander, Hercules	€ 7,50

MARKETING



SUPER BLACK HD

Special Abrasive Floor Pads to clean the concrete for the system of SUPERCONCRETE FAST.

30173HD	Super Black HD	17"/ø430mm	Mon.17"	€ 15,00
30133HD	Super Black HD	13"/ø330mm	Konfort, Rocky 13", Ufo	€ 11,00
30093HD	Super Black HD	9,5"/ø240mm	Lev.Max, Expander, Hercules	€ 9,00

Beton Color Dye Liquid



BETON COLOUR DYE

Concentrate liquid colours to be dilute in 4 l of Acetone to colour concrete floors. **Beton Color above showed colours are indicative.** They are not RAL because they are not varnish but the result of a chemical reaction with the concrete. As a result the tonality can change according with the kind of concrete. We recommend to make a preliminary test to be sure of the colour reached.

code color	Beton Color Dye liquid	Dilute in 4 litres	€ 59,50
------------	------------------------	--------------------	---------

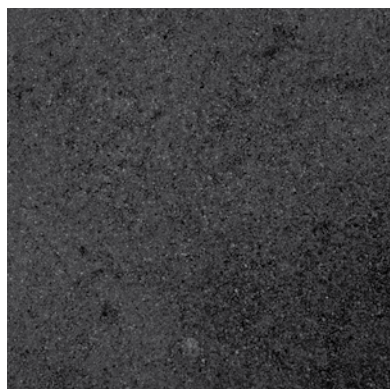

04045L Black



04046L Dark Blue



04048L Light Blue



04049L Dark Brown



04047L Brown Brick



04054L Golden Yellow

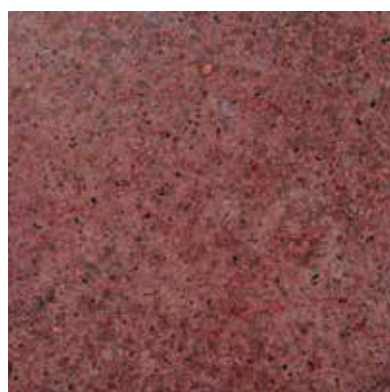

04060L Red Plum



04058L Red Rubino

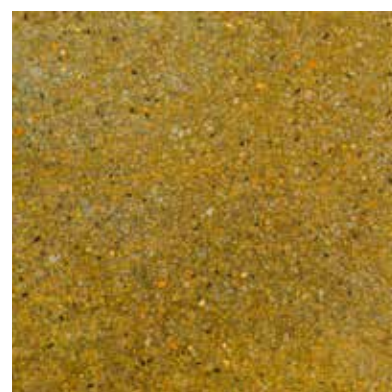

04055L Yellow Ocre



04056L Light Green

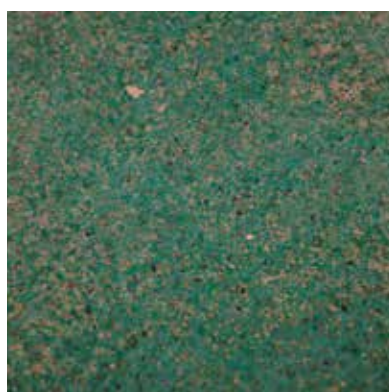

04057L Dark Green



04044L Green Avocado

GRINDING

SINGLE DISC

TOOLS

SPECIAL

VACUUM

CHEMICALS

MARKETING

Polished Copter

GRINDING

SINGLE DISC

TOOLS

SPECIAL

VACUUM

CHEMICALS

MARKETING

To Polish like a mirror concrete floors with Power Trowel machine!







Polished Copter is a conversion kit for power trowel machines that allows the use of abrasives pads and diamonds. With Polish Copter is possible to clean, grind and polish the concrete surface in few steps.

Instructions for new floors:

- When the floor is cured remove the excess of "milk" with SUPERBLACK HD using water.
- Start grinding with DA1 and DA2 series (if necessary start with more aggressive grit such as DA0 or DA00).
- If requested colour the surface with Beton Color Dye.
- Continue polishing with Green Jumper series 3, 4 and 5.
- Apply Beton Guard Lithium.

Instructions for old floors:

- Begin grinding with CK3 using water.
- Proceed with CK4, CK5.
- If necessary colour the surface.
- Grind with CK6.
- Apply Beton Guard Lithium.

PICTURE	CODE	NAME	SIZE	MACHINE	€ each
POLISH COPTER					
To use 3" diamond disc with trowel machines. The kit include 4 blades.					
	PLS2A2	Polish Copter 2	Kit 4 blades A2	for power trowel machine series 90	€ 595,00
	PLS3A3	Polish Copter 3	Kit 4 blades A3	for power trowel machine series 120	€ 765,00
SUPER BLACK HD					
Special abrasive floor pads to clean effectively and to remove concrete milk on industrial floors.					
	30093HD	Super Black HD	9,5"/ø240mm		€ 9,00
METALLIC BOND DIAMOND DISCS					
For smoothing, grinding and to eliminate creasing or over-thicknesses					
	075819	DA00	3"/ø75mm		€ 79,50
	075820	DA0	3"/ø75mm		€ 73,50
	075821	DA1	3"/ø75mm		€ 73,50
	075822	DA2	3"/ø75mm		€ 73,50
DISCOLUX					
Specially for use with polishing powder.					
	28366	Discolux	36"/ø915mm		€ 36,00
JUMPER GREEN DIAMOND TOOLS 3"/ø75mm					
Resin diamond disc for polishing.					
	075493	Jumper Green 3	3"/ø75mm		€ 19,50
	075494	Jumper Green 4	3"/ø75mm		€ 19,50
	075495	Jumper Green 5	3"/ø75mm		€ 19,50
	075496	Jumper Green 6	3"/ø75mm		€ 19,50
	075497	Jumper Green 7	3"/ø75mm		€ 19,50
	075498	Jumper Green 8	3"/ø75mm		€ 19,50
BETON GUARD LITHIUM					
Oil-repellent Once applied it makes a very hard film for maximum protection. It can be applied directly but we suggest polishing with high speed machines such as HURRIKANE. Just like any "film-forming product" it requires maintenance with high speed machines to remove scratches and streaks. Very appreciated in airports, shopping malls and in large areas subject to high traffic of people.					
	00620	Beton Guard Lithium	5 l	Ready to use	€ 280,00

Polished Copter

Transform your "Power Trowel machine in a Grinding machine"

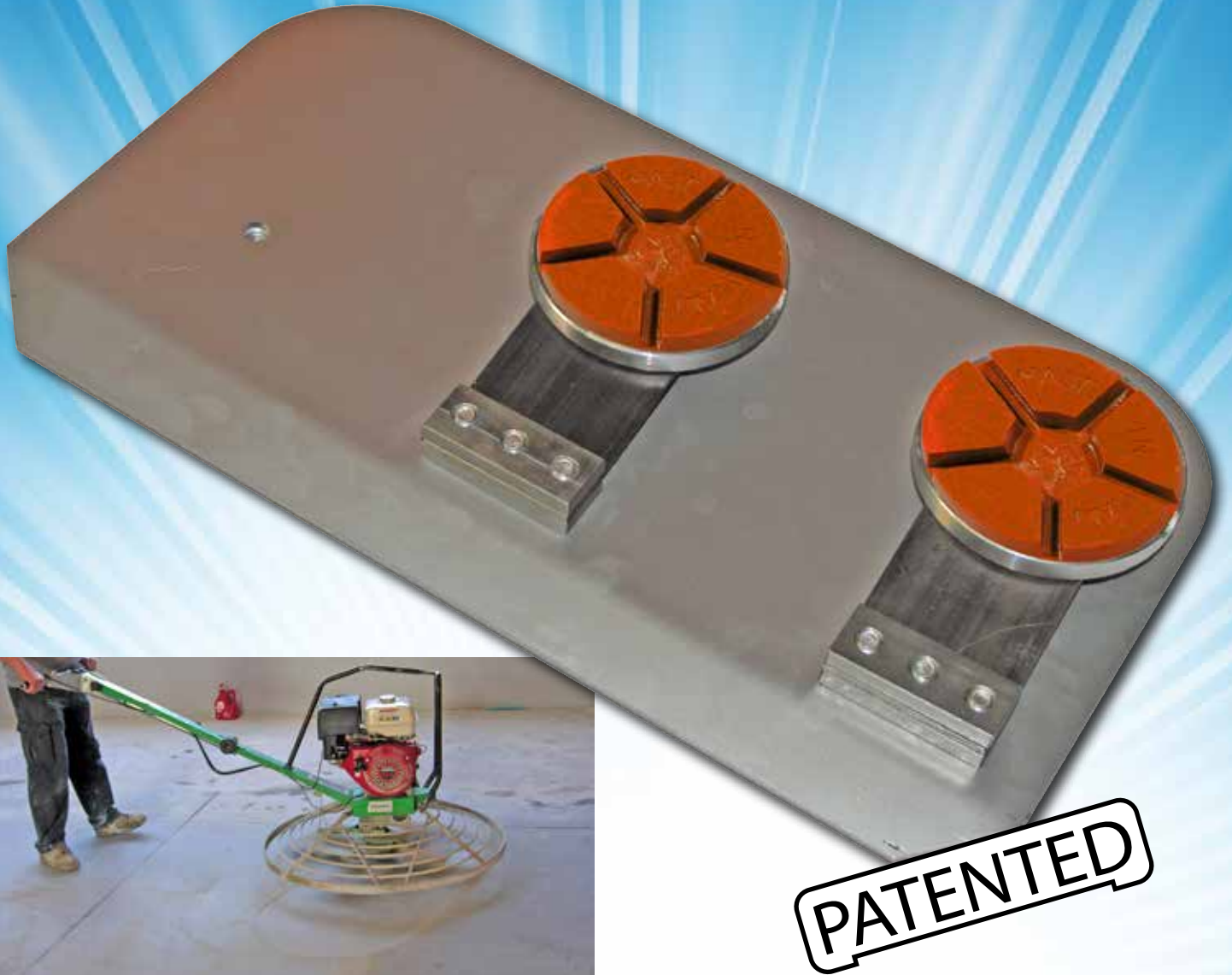

**The best solution for
Concrete, Terrazzo and
Natural stones.**



Concrete



Natural Stones



Terrazzo



▶ Application:

A) Polished concrete, trowelled concrete and concrete overlay (like Utratop or Pandomo) polishing.

B) Marble, Terrazzo and natural stone restoration and polishing.

Can be used wet on natural stone or dry on concrete and screed. Thanks to the flexible support and its design it allows to grind, sand and hone the surface fast leaving a homogeneous finish. Elica is the best solution for semi gloss, honed and matt finish on trowelled concrete or screed without exposing the aggregate.

The best solution for concrete preparation before densification and sealing.

Flexible polishing Diamond pads designed to achieve a scratch-free highly polished finish on marble, terrazzo and natural stone. The Professional BUT easy solution for damaged and scratched floor. Available from grit 60/000 to grit 3000/4.

The Elica series is available in 4", 5.5", 8", 9.5", 13", 16", 17", 18", 20" and 26" size, other sizes upon request.



Guidelines:

Dry system for Polished concrete, Polishing concrete screed and trowelled concrete, concrete overlay.

1. Start grinding with **Elica 00** or **Elica 0** according the condition of the concrete.
2. Apply **Beton Hardener** for densification.
3. Once the Beton Hardener its completely dry, sand the floor with **Elica 2**.

For different finishing follow the instruction below:

- A. For matt finish just apply **Beton Guard Lithium** sealer.
- B. For semi gloss finish proceed with **Elica 3** and after apply **Beton Guard Lithium** sealer.
- C. For gloss finish proceed with **Elica 3** and **4** and after apply **Beton Guard Lithium** sealer.

For daily cleaning of floors treated as A and B in high traffic areas, use **Superclean** Pad with scrubber machine. Does not need chemicals, just water.

For daily cleaning of floors treated as C in high traffic areas use burnishing machine like **Tornado** or **Hurrikane** and HS polishing pad **Discolux**.

WET system for Marble, Terrazzo and natural stones polishing.

1. Start grinding with **Elica 00** or **Elica 0** to remove the scratches ad refresh the surface according the condition of the floor.
2. Hone the floor with **Elica 1, 2** and **3**.
3. Use Klindex stone Polishing Powder **KP92** or **Elica 4** with water for a mechanical polishing process.
4. Wash the floor with stone **Stone Soap**.

For daily cleaning and maintenance in high traffic areas use **Superclean** Pad with scrubber machine and **Stone Soap** cleaner.

TECHNICAL DATA

Model	Grit	Size	Description
Elica 000	60	4"/5,5"/8"/9,5"/13"/16"/17"/18"/20"/26"	Very aggressive Grit. Great for removing big marks from power trowel machines or big scratches on natural stones.
Elica 00	120	4"/5,5"/8"/9,5"/13"/16"/17"/18"/20"/26"	Great for removing big marks from power trowel machines or big scratches on natural stones.
Elica 0	220	4"/5,5"/8"/9,5"/13"/16"/17"/18"/20"/26"	Great for removing light marks from power trowel machines or light scratches on natural stones. It leaves the concrete surfaces ideal condition for densification or Beton Hardener.
Elica 1	400	4"/5,5"/8"/9,5"/13"/16"/17"/18"/20"/26"	To be used after Elica 0. It removes the excess of densification or Beton Hardener and leaves matt finish. It also remove minus spot or light scratches on natural stone.
Elica 2	800	4"/5,5"/8"/9,5"/13"/16"/17"/18"/20"/26"	To be used after Elica 1. It leaves honed finish.
Elica 3	1500	4"/5,5"/8"/9,5"/13"/16"/17"/18"/20"/26"	To be used after Elica 2. It leaves semi gloss finish.
Elica 4	3000	4"/5,5"/8"/9,5"/13"/16"/17"/18"/20"/26"	To be used after Elica 3. It leaves gloss finish.

GRINDING

SINGLE DISC

TOOLS

SPECIAL

VACUUM

CHEMICALS

MARKETING



Elica Floor Pad 5,5" - ø 140mm

601138	Elica 000	grit 60	€ 19,50
601139	Elica 00	grit 120	€ 19,50
601140	Elica 0	grit 220	€ 19,50
601141	Elica 1	grit 400	€ 19,50
601142	Elica 2	grit 800	€ 19,50
601143	Elica 3	grit 1500	€ 19,50
601144	Elica 4	grit 3000	€ 19,50

Elica Floor Pad 13" - ø 330mm

601128	Elica 000	grit 60	€ 39,50
601129	Elica 00	grit 120	€ 39,50
601130	Elica 0	grit 220	€ 39,50
601131	Elica 1	grit 400	€ 39,50
601132	Elica 2	grit 800	€ 39,50
601133	Elica 3	grit 1500	€ 39,50
601134	Elica 4	grit 3000	€ 39,50

Elica Floor Pad 18" - ø 450mm

601178	Elica 000	grit 60	€ 63,00
601179	Elica 00	grit 120	€ 63,00
601180	Elica 0	grit 220	€ 63,00
601181	Elica 1	grit 400	€ 63,00
601182	Elica 2	grit 800	€ 63,00
601183	Elica 3	grit 1500	€ 63,00
601184	Elica 4	grit 3000	€ 63,00



Elica Floor Pad 8" - ø 200mm

601079	Elica 000	grit 60	€ 30,50
601080	Elica 00	grit 120	€ 30,50
601081	Elica 0	grit 220	€ 30,50
601082	Elica 1	grit 400	€ 30,50
601083	Elica 2	grit 800	€ 30,50
601084	Elica 3	grit 1500	€ 30,50
601085	Elica 4	grit 3000	€ 30,50

Elica Floor Pad 16" - ø 410mm

601158	Elica 000	grit 60	€ 57,50
601159	Elica 00	grit 120	€ 57,50
601160	Elica 0	grit 220	€ 57,50
601161	Elica 1	grit 400	€ 57,50
601162	Elica 2	grit 800	€ 57,50
601163	Elica 3	grit 1500	€ 57,50
601164	Elica 4	grit 3000	€ 57,50

Elica Floor Pad 20" - ø 500mm

601198	Elica 000	grit 60	€ 79,50
601199	Elica 00	grit 120	€ 79,50
601200	Elica 0	grit 220	€ 79,50
601201	Elica 1	grit 400	€ 79,50
601202	Elica 2	grit 800	€ 79,50
601203	Elica 3	grit 1500	€ 79,50
601204	Elica 4	grit 3000	€ 79,50



Elica Floor Pad 4" - ø 100mm

601040	Elica 000	grit 60	€ 16,50
601041	Elica 00	grit 120	€ 16,50
601042	Elica 0	grit 220	€ 16,50
601043	Elica 1	grit 400	€ 16,50
601044	Elica 2	grit 800	€ 16,50
601045	Elica 3	grit 1500	€ 16,50
601046	Elica 4	grit 3000	€ 16,50

Elica Floor Pad 9,5" - ø 240mm

601088	Elica 000	grit 60	€ 32,50
601088	Elica 00	grit 120	€ 32,50
601090	Elica 0	grit 220	€ 32,50
601091	Elica 1	grit 400	€ 32,50
601092	Elica 2	grit 800	€ 32,50
601093	Elica 3	grit 1500	€ 32,50
601094	Elica 4	grit 3000	€ 32,50

Elica Floor Pad 17" - ø 430mm

601168	Elica 000	grit 60	€ 58,50
601169	Elica 00	grit 120	€ 58,50
601170	Elica 0	grit 220	€ 58,50
601171	Elica 1	grit 400	€ 58,50
601172	Elica 2	grit 800	€ 58,50
601173	Elica 3	grit 1500	€ 58,50
601174	Elica 4	grit 3000	€ 58,50

Elica Floor Pad 26" - ø 660mm

601260	Elica 000	grit 60	€ 93,50
601261	Elica 00	grit 120	€ 93,50
601262	Elica 0	grit 220	€ 93,50
601263	Elica 1	grit 400	€ 93,50
601264	Elica 2	grit 800	€ 93,50
601265	Elica 3	grit 1500	€ 93,50
601266	Elica 4	grit 3000	€ 93,50

SuperClean Diamond Floor Pads

For daily maintenance of the floors. This step will effectively maintain a high gloss on the surface when used regularly. Its ideal for use on all floor surfaces such as marble, stone, vinyl and linoleum floors, terrazzo and natural stone surfaces. Its also very effective in polishing polish-coated vinyl and linoleum floors.



Save your money



They no need chemical products



They only need water

▶ Diamond Floor Pad for cleaning and for floor maintenance.

We are aware of the importance of always having a clean and well maintained floor, though this is not always easy and not expensive.

The **SuperClean** discs allow you to wash the floor in an effective, ecological and economical way. **SuperClean** is available in all sizes for use with both single disc and scrubbing machines. Using **SuperClean** on regular basis to wash the surface will help achieving an incredibly clean and shiny floor without the use of wax or chemicals.

NEEDS WATER ONLY !

BENEFITS

- Low costs.
- Improved results.
- High customers satisfaction.
- Floor is always clean and shine
- Ecological
- Needs water only

Where to use the SUPERCLEAN?

- Marble and terrazzo
- Klinker and ceramics
- Natural stone
- PVC / vinyl
- Epoxy resin
- Rubber
- Wood
- Superconcrete® - polished concrete

SuperClean Floor pads

605044	SuperClean	4"/100mm	€ 9,90
605054	SuperClean	5,5"/140mm	€ 13,90
605084	SuperClean	8"/200mm	€ 18,50
605094	SuperClean	9,5"/240mm	€ 21,50
605134	SuperClean	13"/330mm	€ 27,50
605164	SuperClean	16"/410mm	€ 37,50
605174	SuperClean	17"/430mm	€ 39,50
605184	SuperClean	18"/450mm	€ 41,50
605204	SuperClean	20"/500mm	€ 46,50



King Conc Pad

Superconcrete HS System

GRINDING

SINGLE DISC

TOOLS

SPECIAL

VACUUM

CHEMICALS

MARKETING

Polished Concrete Diamond Floor Pads

KING CONC are Special Floor pads with the impregnation of diamond abrasive for dry restoration and maintenance of polished concrete and terrazzo floors. Designed to revitalize the shine and the gloss of old and new dulled concrete surfaces. They are available in grit sizes 0, 1, 2, 3 and 4 and in all dimensions. Used dry with Tornado, Hurrikane and high speed machines, they remove scratches, opacity and polish the concrete floor.

Use the KING CONC discs is the easiest and fastest way to turn any trowelled industrial concrete floor into a beautiful, durable, stain-resistant, easy to clean and mirror polished surface. Thanks to the new KING CONC "abrasive diamond discs" technology, to achieve a polished concrete floor has never been so easy.

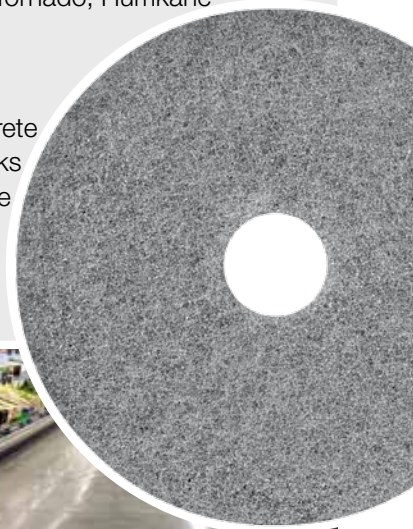

KING CONC 26" - HURRIKANE 28"

30420	King Conc 0	€ 77,50
30421	King Conc 1	€ 77,50
30422	King Conc 2	€ 77,50
30423	King Conc 3	€ 77,50
30424	King Conc 4	€ 77,50



KING CONC 24" - HURRIKANE 24"

602240	King Conc 0	€ 69,50
602241	King Conc 1	€ 69,50
602242	King Conc 2	€ 69,50
602243	King Conc 3	€ 69,50
602244	King Conc 4	€ 69,50



KING CONC 20" - TORNADO

30410	King Conc 0	€ 59,50
30411	King Conc 1	€ 59,50
30412	King Conc 2	€ 59,50
30413	King Conc 3	€ 59,50
30414	King Conc 4	€ 59,50



KING CONC 17" - FUTURA

30400	King Conc 0	€ 49,50
30401	King Conc 1	€ 49,50
30402	King Conc 2	€ 49,50
30403	King Conc 3	€ 49,50
30404	King Conc 4	€ 49,50



KING CONC 5,5" - EXTREMA

30430	King Conc 0	€ 24,50
30431	King Conc 1	€ 24,50
30432	King Conc 2	€ 24,50
30433	King Conc 3	€ 24,50
30434	King Conc 4	€ 24,50

HURRIKANE and KING CONC:
The easiest and fastest system to grind and polish large surfaces.

After



Before



GRINDING

SINGLE DISC

TOOLS

SPECIAL

VACUUM

CHEMICALS

MARKETING

DIAMOND TOOLS FOR POLISHING MARBLE FLOORS



MS series

Metallic diamond discs for grinding marble floors.

PICTURE	CODE	NAME	SIZE	MACHINE	€ each
---------	------	------	------	---------	--------



MS Diamond Tools 4"/ø100mm 7 Segments

100900	MS0		4"/ø100mm	Levighetor 640	€ 136,00
100901	MS1		4"/ø100mm	Levighetor 640	€ 132,50
100902	MS2		4"/ø100mm	Levighetor 640	€ 132,00



MS Diamond Tools 5,5"/ø140mm 7 Segments

140900	MS0		5,5"/ø140mm	Levighetor 645	€ 136,00
140901	MS1		5,5"/ø140mm	Levighetor 645	€ 136,00
140902	MS2		5,5"/ø140mm	Levighetor 645	€ 136,00



MS Diamond Tools 8"/ø200mm 7 Segments

200900	MS0		8"/ø200mm	Lev.650, Herc.450-451-550-551, Exp 530	€ 145,00
200901	MS1		8"/ø200mm	Lev.650, Herc.450-451-550-551, Exp 530	€ 145,00
200902	MS2		8"/ø200mm	Lev.650, Herc.450-451-550-551, Exp 530	€ 145,00



MS Diamond Tools 9,5"/ø240mm 12 Segments

240900MS12S	MS0		9,5"/ø240mm	Exp.1000-850-750-650-580, Lev.Max, Herc.800-650-601	€ 245,00
240901MS12S	MS1		9,5"/ø240mm	Exp.1000-850-750-650-580, Lev.Max, Herc.800-650-601	€ 245,00
240902MS12S	MS2		9,5"/ø240mm	Exp.1000-850-750-650-580, Lev.Max, Herc.800-650-601	€ 245,00



MS Diamond Tools 9,5"/ø240mm 16 Segments

240900MS16S	MS0		9,5"/ø240mm	Exp.1000-850-750-650-580, Lev.Max, Herc.800-650-601	€ 295,00
240901MS16S	MS1		9,5"/ø240mm	Exp.1000-850-750-650-580, Lev.Max, Herc.800-650-601	€ 295,00
240902MS16S	MS2		9,5"/ø240mm	Exp.1000-850-750-650-580, Lev.Max, Herc.800-650-601	€ 295,00



MS Diamond Tools 13,5"/ø340mm 16 Segments

340900MS16S	MS0		13,5"/ø340mm	Expander 950, Hercules 750	€ 315,00
340901MS16S	MS1		13,5"/ø340mm	Expander 950, Hercules 750	€ 315,00
340902MS16S	MS2		13,5"/ø340mm	Expander 950, Hercules 750	€ 315,00

GRINDING

SINGLE DISC

TOOLS

SPECIAL

VACUUM

CHEMICALS

MARKETING

ORANGE series

Diamond resin discs to remove mastic and for abrasive Marble, Terrazzo and Limestone.

PICTURE	CODE	NAME	SIZE	MACHINE	€ each
	JUMPER CK ORANGE Diamond Tools				
	075793OR	Jumper Orange 3	3"/ø75mm	Lev650,Hercules,Lev.Max,Exp.	€ 20,50
	100793AS	CK3 Orange	4"/ø100mm	Levighetor 640	€ 39,50
	140793AS	CK3 Orange	5,5"/ø140mm	Levighetor 645	€ 43,50

YELLOW series

Resinbond diamond disc for polishing marble floors. For abrasive marbles like travertino we suggest to use series ck orange.

JUMPER YELLOW Diamond Tools 3"/ø75mm VELCRO BACKED

	0750060	Jumper Yellow grit 60	3"/ø75mm	Lev.,Hercules,Lev.Max,Expander	€ 25,00
	0750120	Jumper Yellow grit 120	3"/ø75mm	Lev.,Hercules,Lev.Max,Expander	€ 25,00
	0750220	Jumper Yellow grit 220	3"/ø75mm	Lev.,Hercules,Lev.Max,Expander	€ 25,00
	0750400	Jumper Yellow grit 400	3"/ø75mm	Lev.,Hercules,Lev.Max,Expander	€ 25,00
	0750800	Jumper Yellow grit 800	3"/ø75mm	Lev.,Hercules,Lev.Max,Expander	€ 25,00
	0751500	Jumper Yellow grit 1500	3"/ø75mm	Lev.,Hercules,Lev.Max,Expander	€ 25,00

MK YELLOW Diamond Tools 4"/ø100mm

	100693	MK 3	4"/ø100mm	Levighetor 640	€ 47,00
	100694	MK 4	4"/ø100mm	Levighetor 640	€ 47,00
	100695	MK 5	4"/ø100mm	Levighetor 640	€ 47,00
	100696	MK 6	4"/ø100mm	Levighetor 640	€ 47,00
	100697	MK 7	4"/ø100mm	Levighetor 640	€ 47,00
	100698	MK 8	4"/ø100mm	Levighetor 640	€ 47,00

MK YELLOW Diamond Tools 5,5"/ø140mm

	140693	MK 3	5,5"/ø140mm	Levighetor 645	€ 49,00
	140694	MK 4	5,5"/ø140mm	Levighetor 645	€ 49,00
	140695	MK 5	5,5"/ø140mm	Levighetor 645	€ 49,00
	140696	MK 6	5,5"/ø140mm	Levighetor 645	€ 49,00
	140697	MK 7	5,5"/ø140mm	Levighetor 645	€ 49,00
	140698	MK 8	5,5"/ø140mm	Levighetor 645	€ 49,00

POLISH POWDER

	000650	Polish KP92	kg 5	For standard marbles and limestone	€ 82,00
	000663	Polish KP85	kg 5	For marble, terrazzo, porcelain	€ 69,00
	000647	Polish KMT	kg 5	for marble very soft	€ 86,00
	000649	Polish COLOR	kg 5	for colored or ferrous marbles	€ 146,50

STONE SOAP

Daily cleaner and sealer soap for polished marble and terrazzo floors. It leaves the floors waterproof and high glossy. Ideal to be used to wash the floor after Polish powder.

	00604LT5	Stone Soap	5 l		€ 75,00
	00604Box	Stone Soap	3x5 l		€ 208,00

CRYSTALLIZING MARBLE

Crystallization products to maintain polished marble and terrazzo floor surfaces. Their formula allows the surface to "breathe" through microscopic pores of the stone. Provides a high level of long lasting and resistant shine in first crystallizations, being also suitable for periodical maintenance of floors already crystallized. Its use guarantees the maximum protection for the pavement for long time. High Gloss - Not slippery.

	04828TAK4	Kristallux	4x5 l	Liquid Crystallizer for marbles.	€ 154,00
	04838TA	Kristal Green	3,8 l	Polish cream for artificial marble, conglomerate and marble-quartz	€ 122,00

DIAMOND TOOLS FOR POLISHING TERRAZZO AND LIMESTONE



MTS series

Diamond tools for travertine, terrazzo, limestone, agglomerate and abrasive marble floors. Wet & dry system.

PICTURE	CODE	NAME	SIZE	MACHINE	€ each
---------	------	------	------	---------	--------



MTS Diamond Tools 4"/ø100mm 5 Segments

100910AS	MTS0	4"/ø100mm	Levighetor 640	€ 98,00
100911AS	MTS1	4"/ø100mm	Levighetor 640	€ 98,00
100912AS	MTS2	4"/ø100mm	Levighetor 640	€ 98,00



MTS Diamond Tools 5,5"/ø140mm 5 Segments

140910AS	MTS0	5,5"/ø140mm	Levighetor 645	€ 104,00
140911AS	MTS1	5,5"/ø140mm	Levighetor 645	€ 104,00
140912AS	MTS2	5,5"/ø140mm	Levighetor 645	€ 104,00



MTS Diamond Tools 8"/ø200mm 4 Segments

200410	MTS0	8"/ø200mm	Lev.650, Herc.450-451-550-551, Exp 530	€ 106,00
200411	MTS1	8"/ø200mm	Lev.650, Herc.450-451-550-551, Exp 530	€ 106,00
200412	MTS2	8"/ø200mm	Lev.650, Herc.450-451-550-551, Exp 530	€ 106,00



MTS Diamond Tools 8"/ø200mm 6 Segments

200910QA	MTS0	8"/ø200mm	Lev.650, Herc.450-451-550-551, Exp 530	€ 126,00
200911QA	MTS1	8"/ø200mm	Lev.650, Herc.450-451-550-551, Exp 530	€ 126,00
200912QA	MTS2	8"/ø200mm	Lev.650, Herc.450-451-550-551, Exp 530	€ 126,00



MTS Diamond Tools 9,5"/ø240mm 6 Segments

240910S6QA	MTS0	9,5"/ø240mm	Exp.1000-850-750-650-580, Lev.Max, Herc.800-650-601	€ 135,00
240911S6QA	MTS1	9,5"/ø240mm	Exp.1000-850-750-650-580, Lev.Max, Herc.800-650-601	€ 135,00
240912S6QA	MTS2	9,5"/ø240mm	Exp.1000-850-750-650-580, Lev.Max, Herc.800-650-601	€ 135,00



MTS Diamond Tools 9,5"/ø240mm 12 Segments

240910S12QA	MTS0	9,5"/ø240mm	Exp.1000-850-750-650-580, Lev.Max, Herc.800-650-601	€ 199,00
240911S12QA	MTS1	9,5"/ø240mm	Exp.1000-850-750-650-580, Lev.Max, Herc.800-650-601	€ 199,00
240912S12QA	MTS2	9,5"/ø240mm	Exp.1000-850-750-650-580, Lev.Max, Herc.800-650-601	€ 199,00



BETON HARDENER

BETON HARDENER is a special product to improve the hardness and quality of new and old concrete floors. It reacts with the salt of cement increasing the hardness and resistance to the abrasion and protecting against oils, greases and other agents contaminating.

04820	Beton Hardener K10	5 Lt	SODIUM-POTASSIUM	€ 52,00
04822	Beton Hardener Lithium	5 Lt	LITHIUM ready to use	€ 125,00
04818	Beton Hardener K35	25 Lt.	SODIUM-POTASSIUM	€ 168,00

GRINDING

SINGLE DISC

TOOLS

SPECIAL

VACUUM

CHEMICALS

MARKETING

ORANGE series

Diamond resin discs for Terrazzo, Limestone and abrasive Marble floors. For Terrazzo rich of cement use series "Green".

PICTURE	CODE	NAME	SIZE	MACHINE	€ each
---------	------	------	------	---------	--------

JUMPER ORANGE Diamond Tools 3"/ø75mm VELCRO BACKED



075793OR	Jumper Orange 3	3"/ø75mm	Lev.,Hercules,Lev.Max,Expander	€ 20,50
075794OR	Jumper Orange 4	3"/ø75mm	Lev.,Hercules,Lev.Max,Expander	€ 20,50
075795OR	Jumper Orange 5	3"/ø75mm	Lev.,Hercules,Lev.Max,Expander	€ 20,50
075796OR	Jumper Orange 6	3"/ø75mm	Lev.,Hercules,Lev.Max,Expander	€ 20,50
075797OR	Jumper Orange 7	3"/ø75mm	Lev.,Hercules,Lev.Max,Expander	€ 20,50
075798OR	Jumper Orange 8	3"/ø75mm	Lev.,Hercules,Lev.Max,Expander	€ 20,50

CK ORANGE Diamond Tools 4"/ø100mm



100793	CK Orange 3	4"/ø100mm	Levighetor 640	€ 39,50
100794	CK Orange 4	4"/ø100mm	Levighetor 640	€ 39,50
100795	CK Orange 5	4"/ø100mm	Levighetor 640	€ 39,50
100796	CK Orange 6	4"/ø100mm	Levighetor 640	€ 39,50
100797	CK Orange 7	4"/ø100mm	Levighetor 640	€ 39,50
100798	CK Orange 8	4"/ø100mm	Levighetor 640	€ 39,50

CK ORANGE Diamond Tools 5,5"/ø140mm



140793	CK Orange 3	5,5"/ø140mm	Levighetor 645	€ 43,50
140794	CK Orange 4	5,5"/ø140mm	Levighetor 645	€ 43,50
140795	CK Orange 5	5,5"/ø140mm	Levighetor 645	€ 43,50
140796	CK Orange 6	5,5"/ø140mm	Levighetor 645	€ 43,50
140797	CK Orange 7	5,5"/ø140mm	Levighetor 645	€ 43,50
140798	CK Orange 8	5,5"/ø140mm	Levighetor 645	€ 43,50

JUMBO GREEN Diamond Tools

Requires tool holder amortized for Jumbo.



AP011102	Plate Jumbo (3pcs)	9,5"/ø240mm	Exp.1000-850-750-650-580, Lev.Max, Herc.800-650-601	€ 590,00
PD3201	Plate Jumbo (3pcs)	13"/ø340mm	Expander 950, Hercules 750	€ 630,00
JMB493	Jumbo Green 3	Jumbo	Exp.1000-850-750-650-580, Lev.Max, Herc.800-650-601	€ 66,50
JMB494	Jumbo Green 4	Jumbo	Exp.1000-850-750-650-580, Lev.Max, Herc.800-650-601	€ 66,50
JMB495	Jumbo Green 5	Jumbo	Exp.1000-850-750-650-580, Lev.Max, Herc.800-650-601	€ 66,50
JMB496	Jumbo Green 6	Jumbo	Exp.1000-850-750-650-580, Lev.Max, Herc.800-650-601	€ 66,50
JMB497	Jumbo Green 7	Jumbo	Exp.1000-850-750-650-580, Lev.Max, Herc.800-650-601	€ 66,50
JMB498	Jumbo Green 8	Jumbo	Exp.1000-850-750-650-580, Lev.Max, Herc.800-650-601	€ 66,50

BRILL&MORE

A silicon-based stone polish to improve the shine on marble, granite and terrazzo. It also water-proofs the surface of the stone. Ideal for routine maintenance.



01126SBox	Brill&More	12 x l 1	Solvent Base	€ 245,00
-----------	------------	----------	--------------	----------

POLISH TERRAZZO



000648	Polish Terrazzo	kg 5		€ 155,00
--------	-----------------	------	--	----------

KRISTAL GREEN

Polish cream for artificial marble, conglomerate and marble-quartz.



04838TA	Kristal Green	3,8 l		€ 122,00
---------	---------------	-------	--	----------

GRINDING

SINGLE DISC

TOOLS

SPECIAL

VACUUM

CHEMICALS

MARKETING

DIAMOND TOOLS FOR POLISHING GRANITE AND GRES TILES



GRINDING

SINGLE DISC

TOOLS

SPECIAL

VACUUM

CHEMICALS

MARKETING

GS series

Metallic diamond discs for grinding granite floors.

PICTURE	CODE	NAME	SIZE	MACHINE	€ each
---------	------	------	------	---------	--------



GS Diamond Tools 4"/ø100mm 6 Segments

100711	GS1		4"/ø100mm	Levighetor 640	€ 145,00
100712	GS2		4"/ø100mm	Levighetor 640	€ 145,00
100713	GS3		4"/ø100mm	Levighetor 640	€ 145,00



GS Diamond Tools 5,5"/ø140mm 6 Segments

140711	GS1		5,5"/ø140mm	Levighetor 645	€ 149,00
140712	GS2		5,5"/ø140mm	Levighetor 645	€ 149,00
140713	GS3		5,5"/ø140mm	Levighetor 645	€ 149,00



GS Diamond Tools 8"/ø200mm 6 Segments

200711GS6S	GS1		8"/ø200mm	Lev.650, Herc.450-451-550-551, Exp 530	€ 169,00
200712GS6S	GS2		8"/ø200mm	Lev.650, Herc.450-451-550-551, Exp 530	€ 159,00
200713GS6S	GS3		8"/ø200mm	Lev.650, Herc.450-451-550-551, Exp 530	€ 159,00



GS Diamond Tools 9,5"/ø240mm 12 Segments

240716GS12S	GS1		9,5"/ø240mm	Exp.1000-850-750-650-580, Lev.Max, Herc.800-650-601	€ 285,00
240717GS12S	GS2		9,5"/ø240mm	Exp.1000-850-750-650-580, Lev.Max, Herc.800-650-601	€ 265,00
240718 GS12S	GS3		9,5"/ø240mm	Exp.1000-850-750-650-580, Lev.Max, Herc.800-650-601	€ 265,00



GSDA Diamond Tools 8"/ø200mm 6 Segments

200690	GSDA0		8"/ø200mm	Lev.650, Herc.450-451-550-551, Exp 530	€ 126,00
200691	GSDA1		8"/ø200mm	Lev.650, Herc.450-451-550-551, Exp 530	€ 126,00
200692	GSDA2		8"/ø200mm	Lev.650, Herc.450-451-550-551, Exp 530	€ 126,00



GSDA Diamond Tools 9,5"/ø240mm 6 Segments

240690	GSDA0		9,5"/ø240mm	Exp.1000-850-750-650-580, Lev.Max, Herc.800-650-601	€ 135,00
240691	GSDA1		9,5"/ø240mm	Exp.1000-850-750-650-580, Lev.Max, Herc.800-650-601	€ 135,00
240692	GSDA2		9,5"/ø240mm	Exp.1000-850-750-650-580, Lev.Max, Herc.800-650-601	€ 135,00

GK RED series

Resinbond diamond disc for polishing granite floors.

PICTURE	CODE	NAME	SIZE	MACHINE	€ each
---------	------	------	------	---------	--------

JUMPER RED Diamond Tools 3"/ø75mm VELCRO BACKED



075733	Jumper Red 3	3"/ø75mm	Lev.,Hercules,Lev.Max,Expander	€ 25,00
075734	Jumper Red 4	3"/ø75mm	Lev.,Hercules,Lev.Max,Expander	€ 25,00
075735	Jumper Red 5	3"/ø75mm	Lev.,Hercules,Lev.Max,Expander	€ 25,00
075736	Jumper Red 6	3"/ø75mm	Lev.,Hercules,Lev.Max,Expander	€ 25,00
075737	Jumper Red 7	3"/ø75mm	Lev.,Hercules,Lev.Max,Expander	€ 25,00
075738	Jumper Red 8	3"/ø75mm	Lev.,Hercules,Lev.Max,Expander	€ 25,00
075739	Jumper Red 9	3"/ø75mm	Lev.,Hercules,Lev.Max,Expander	€ 25,00

GK RED Diamond Tools 4"/ø100mm



100733	GK Red 3	4"/ø100mm	Levighetor 640	€ 47,00
100734	GK Red 4	4"/ø100mm	Levighetor 640	€ 47,00
100735	GK Red 5	4"/ø100mm	Levighetor 640	€ 47,00
100736	GK Red 6	4"/ø100mm	Levighetor 640	€ 47,00
100737	GK Red 7	4"/ø100mm	Levighetor 640	€ 47,00
100738	GK Red 8	4"/ø100mm	Levighetor 640	€ 47,00
100739	GK Red 9	4"/ø100mm	Levighetor 640	€ 47,00

POLISH KG

The best polishing powder for granites.



000657	Polish Kg	kg 5		€ 195,00
000659	Polish Kg Clear	kg 5		€ 195,00

KRISTAL BLU

KRISTAL BLU is a new polishing cream specifically made for polishing granite and gres. The periodic use allows to maintain the brightness and improve the resistance to high traffic. Periodically used, it avoids the micro-abrasion and opacification of floor.



04826TA	Kristal Blu	3,8 l / 1 Gal		€ 89,00
04826Box	Kristal Blu	4 x 3,8 l		€ 340,00

ANTIKO 60

Water-oil-repellent antique finishing for interior.



00619	Antiko 60	1 Lt	Solvent Based	€ 19,50
00619Box	Antiko 60	12 x 1 Lt	Solvent Based	€ 210,00

KORREKTOR

An effective stone colour enhancer ideal for darker-coloured stones such as marble, granite, sandstone, etc.



01122BLU	Korrektor	1 l	Blue	€ 46,50
01122N	Korrektor	1 l	Black	€ 46,50
01122M	Korrektor	1 l	Brown	€ 46,50
01122V	Korrektor	1 l	Green	€ 46,50
01122R	Korrektor	1 l	Red	€ 46,50

FOR MARBLE, TERRAZZO, GRANITE AND GRES

JUMPER BLACK series

Resinbond diamond disc with special components, designed for mastic and grouting removal.

PICTURE	CODE	NAME	SIZE	MACHINE	€ each
---------	------	------	------	---------	--------



JUMPER BLACK Diamond Tools 3"/ø75mm VELCRO BACKED

075383	Jumper Black 3	3"/75mm	Lev.,Hercules,Lev.Max,Expander	€ 21,50
075384	Jumper Black 4	3"/75mm	Lev.,Hercules,Lev.Max,Expander	€ 21,50
075385	Jumper Black 5	3"/75mm	Lev.,Hercules,Lev.Max,Expander	€ 21,50



JUMPER BLACK Diamond Tools 4"/ø100mm VELCRO BACKED

100383	Jumper Black 3	4"/100mm	Lev.,Hercules,Lev.Max,Expander	€ 31,50
100384	Jumper Black 4	4"/100mm	Lev.,Hercules,Lev.Max,Expander	€ 31,50
100385	Jumper Black 5	4"/100mm	Lev.,Hercules,Lev.Max,Expander	€ 31,50

PAVELUX M series

PAVELUX are tools for removing mastic and grinding any very abrasive floors.

PICTURE	CODE	NAME	SIZE	MACHINE	€ each
---------	------	------	------	---------	--------



PAVELUX M Diamond Tools 4"/ø100mm

100253	Pavelux M 3	4"/ø100mm	Levighetor 640	€ 15,50
100254	Pavelux M 4	4"/ø100mm	Levighetor 640	€ 15,50
100255	Pavelux M 5	4"/ø100mm	Levighetor 640	€ 15,50



PAVELUX M Diamond Tools 5,5"/ø140mm

140253	Pavelux M 3	5,5"/ø140mm	Levighetor 645	€ 21,75
140254	Pavelux M 4	5,5"/ø140mm	Levighetor 645	€ 21,75
140255	Pavelux M 5	5,5"/ø140mm	Levighetor 645	€ 21,75





DIAMOND TOOLS FOR ANTIQUE FINISHING



Standard Process: •1) Start grinding with ANTIKE BRUSH grit 46 until you obtain an irregular surface. In case you want to achieve a very irregular surface, start with ANTIKE BRUSH grit 36 or STEEL BRUSH. •2) Proceed with ANTIKE FLOOR grit 70. •3) Complete the work with grit 120 and grit 240, in order to achieve an antique look with semi-polished finish. 4) To obtain a polished look, proceed with antique floor grit 320 and grit 500. •5) To leave the surface waterproofed and to improve the colour, apply "ANTIKO".

ANTIKE FLOOR series

The ANTIKE FLOOR BRUSHES are the best way to achieve an antique look on marble floors in a natural and strictly mechanical way without using any chemical products. Do not apply any extra weight to avoid bending the bristles.

PICTURE	CODE	NAME	SIZE	MACHINE	€ each
---------	------	------	------	---------	--------

STEEL BRUSH



10009	Steel Brush	4"/ø100mm	Levighetor 640	€ 68,00
14009	Steel Brush	5,5"/ø140mm	Levighetor 645, Timba	€ 78,00

ANTIKE FLOOR Tools 4"/ø100mm



155036	Antike Floor grit 36	4"/ø100mm	Levighetor 640	€ 44,50
155046	Antike Floor grit 46	4"/ø100mm	Levighetor 640	€ 44,50
155070	Antike Floor grit 70	4"/ø100mm	Levighetor 640	€ 44,50
155120	Antike Floor grit 120	4"/ø100mm	Levighetor 640	€ 44,50
155220	Antike Floor grit 220	4"/ø100mm	Levighetor 640	€ 44,50
155320	Antike Floor grit 320	4"/ø100mm	Levighetor 640	€ 44,50
155500	Antike Floor grit 500	4"/ø100mm	Levighetor 640	€ 44,50

ANTIKE FLOOR Tools 5,5"/ø140mm



153036	Antike Floor grit 36	5,5"/ø140mm	Levighetor 645, Timba	€ 58,00
153046	Antike Floor grit 46	5,5"/ø140mm	Levighetor 645, Timba	€ 58,00
153070	Antike Floor grit 70	5,5"/ø140mm	Levighetor 645, Timba	€ 58,00
153120	Antike Floor grit 120	5,5"/ø140mm	Levighetor 645, Timba	€ 58,00
153220	Antike Floor grit 220	5,5"/ø140mm	Levighetor 645, Timba	€ 58,00
153320	Antike Floor grit 320	5,5"/ø140mm	Levighetor 645, Timba	€ 58,00
153500	Antike Floor grit 500	5,5"/ø140mm	Levighetor 645, Timba	€ 58,00

ANTIKE FLOOR Tools 8"/ø200mm



200036	Antike Floor grit 36	8"/ø200mm	Lev.650, Herc.450-451-550-551, Exp 530	€ 155,00
200046	Antike Floor grit 46	8"/ø200mm	Lev.650, Herc.450-451-550-551, Exp 530	€ 155,00
200070	Antike Floor grit 70	8"/ø200mm	Lev.650, Herc.450-451-550-551, Exp 530	€ 155,00
200120	Antike Floor grit 120	8"/ø200mm	Lev.650, Herc.450-451-550-551, Exp 530	€ 155,00
200220	Antike Floor grit 220	8"/ø200mm	Lev.650, Herc.450-451-550-551, Exp 530	€ 155,00
200320	Antike Floor grit 320	8"/ø200mm	Lev.650, Herc.450-451-550-551, Exp 530	€ 155,00
200500	Antike Floor grit 500	8"/ø200mm	Lev.650, Herc.450-451-550-551, Exp 530	€ 155,00

GRINDING

SINGLE DISC

TOOLS

SPECIAL

VACUUM

CHEMICALS

MARKETING

PICTURE	CODE	NAME	SIZE	MACHINE	€ each
---------	------	------	------	---------	--------

ANTIKE FLOOR Tools 9,5"/ø240mm



24036	Antike Floor grit 36	9,5"/ø240mm	Exp.1000-850-750-650-580, Lev.Max, Herc.800-650-601	€ 185,00
240046	Antike Floor grit 46	9,5"/ø240mm	Exp.1000-850-750-650-580, Lev.Max, Herc.800-650-601	€ 185,00
240070	Antike Floor grit 70	9,5"/ø240mm	Exp.1000-850-750-650-580, Lev.Max, Herc.800-650-601	€ 185,00
240120	Antike Floor grit 120	9,5"/ø240mm	Exp.1000-850-750-650-580, Lev.Max, Herc.800-650-601	€ 185,00
240220	Antike Floor grit 220	9,5"/ø240mm	Exp.1000-850-750-650-580, Lev.Max, Herc.800-650-601	€ 185,00
24320	Antike Floor grit 320	9,5"/ø240mm	Exp.1000-850-750-650-580, Lev.Max, Herc.800-650-601	€ 185,00
240500	Antike Floor grit 500	9,5"/ø240mm	Exp.1000-850-750-650-580, Lev.Max, Herc.800-650-601	€ 185,00



PICTURE	CODE	NAME	SIZE	TYPE	€ each
---------	------	------	------	------	--------



KLINLUX 5 I

Polishing wax carnauba based.

04120	Klinlux	Box 4 x 5 l	€ 132,00
-------	---------	-------------	----------



KI WATERPROOFING 1 I

Water repellent sealer for both indoor and outdoor applications. It's ideal for marble, granite and any other natural stone.

00646SB	KI	1 l	Solvent Based	€ 26,50
00646SBBox	KI	12 x 1 l	Solvent Based	€ 295,00



ANTIKO 60

Water and oil-repellent for indoor use to produce a satin finish antique look.

00619	Antiko 60	1 l	Solvent Based	€ 19,50
00619Box	Antiko 60	12 x 1 l	Solvent Based	€ 210,00

GRINDING

SINGLE DISC

TOOLS

SPECIAL

VACUUM

CHEMICALS

MARKETING

TRAPEZOID DIAMONDS TOOLS LINE

SKRAPER series

Very aggressive Poly crystalline Diamond used for the removal of thick coatings, glue, adhesives and screeds. SKRAPER has been designed for an incredibly fast and aggressive removal.

PICTURE	CODE	NAME	SIZE	TYPE	€ each
	SKRAPER TRAPEZOID				
	70090	Skraper Trapezoid	5,5"/ø140mm	2 Segments	€ 85,00

BT series

Diamond tools with round segments designed for effective grinding and removing resin and varnish. Also suitable for grinding concrete floors.

PICTURE	CODE	NAME	SIZE	TYPE	€ each
	BT00 TRAPEZOID				
	70049BT1S	BT00 Trapezoid	grit 20	1 Segment	€ 36,00
	70049BT2S	BT00 Trapezoid	grit 20	2 Segments	€ 49,00

DA series

Diamond tools for medium abrasive concrete floors.

PICTURE	CODE	NAME	SIZE	TYPE	€ each
	DA TRAPEZOID				
	700819	DA00 Trapezoid	grit 20	2 Segments	€ 54,00
	700820	DA0 Trapezoid	grit 40	2 Segments	€ 39,00
	700821	DA1 Trapezoid	grit 70	2 Segments	€ 39,00
	700822	DA2 Trapezoid	grit 140	2 Segments	€ 39,00

CA series

Diamond tools for abrasive concrete.

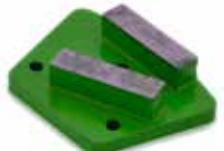
PICTURE	CODE	NAME	SIZE	TYPE	€ each
	CA TRAPEZOID				
	700839	CA00 Trapezoid	grit 16-20	2 Segments	€ 64,00
	700840	CA0 Trapezoid	grit 30-40	2 Segments	€ 59,00
	700841	CA1 Trapezoid	grit 60-80	2 Segments	€ 56,00
	700842	CA2 Trapezoid	grit 120-150	2 Segments	€ 52,00

series CF

Diamond tools for asphalt and very abrasive concrete.

PICTURE	CODE	NAME	SIZE	TYPE	€ each
	CF TRAPEZOID				
	700859	CF00 Trapezoid	grit 16-20	2 Segments	€ 75,00
	700860	CF0 Trapezoid	grit 30-40	2 Segments	€ 69,00
	700861	CF1 Trapezoid	grit 60-80	2 Segments	€ 49,00

GRINDING

SINGLE DISC

TOOLS

SPECIAL

VACUUM

CHEMICALS

MARKETING

CD series

Diamond tools for hard concrete floors. Not for use on abrasive floors.

PICTURE	CODE	NAME	SIZE	TYPE	€ each
	CD TRAPEZOID 2 Segments				
	70031CD2S	CD00 Trapezoid	grit 20	2 Segments	€ 56,00
	70032CD2S	CD0 Trapezoid	grit 40	2 Segments	€ 49,00
	70033CD2S	CD1 Trapezoid	grit 70	2 Segments	€ 47,00
	70034CD2S	CD2 Trapezoid	grit 140	2 Segments	€ 45,00

MS series

Trapezoid diamond tools for marble floors.

PICTURE	CODE	NAME	SIZE	TYPE	€ each
	MS TRAPEZOID				
	70000	MS0 Trapezoid		3 Segments	€ 61,00
	70001	MS1 Trapezoid		3 Segments	€ 61,00
	70002	MS2 Trapezoid		3 Segments	€ 61,00

GSDA series

Trapezoid diamond tools for granite floors.

PICTURE	CODE	NAME	SIZE	TYPE	€ each
	GSDA TRAPEZOID				
	70014	GSDA00 Trapezoid		2 Segments	€ 54,00
	70015	GSDA0 Trapezoid		2 Segments	€ 39,00
	70016	GSDA1 Trapezoid		2 Segments	€ 39,00
	70017	GSDA2 Trapezoid		2 Segments	€ 39,00

HAND Diamond series

Hand pads are designed to improve quick grinding and polishing for manual application. They are available in resin bond "R" or in electroplated "E".

PICTURE	CODE	NAME	SIZE	TYPE	€ each
	HAND DIAMOND TOOLS				
	00911R	Hand Pad Resinbond	grit 60		€ 11,88
	00912R	Hand Pad Resinbond	grit 120		€ 11,88
	00913R	Hand Pad Resinbond	grit 220		€ 11,88
	00914R	Hand Pad Resinbond	grit 400		€ 11,88
	00915R	Hand Pad Resinbond	grit 800		€ 11,88
	00916R	Hand Pad Resinbond	grit 1800		€ 11,88
	00911E	Hand Pad Electroplated	grit 60		€ 39,50
	00912E	Hand Pad Electroplated	grit 120		€ 36,50
	00913E	Hand Pad Electroplated	grit 220		€ 31,50



VELCRO BACKED DIAMOND DISCS

INTERNATIONAL CODE OF DIAMOND DISCS. The colours show the grit.

30	60	120	220	400	800	1800	3500



PUMA series

Flexible resin bonded diamond disc designed for universal application.

PICTURE	CODE	NAME	SIZE	THICKNESS	€ each
PUMA 4"/ø100mm					
	1050060	Puma grit 60	4"/ø100mm	4mm	€ 14,50
	1050120	Puma grit 120	4"/ø100mm	4mm	€ 14,50
	1050220	Puma grit 220	4"/ø100mm	4mm	€ 14,50
	1050400	Puma grit 400	4"/ø100mm	4mm	€ 14,50
	1050800	Puma grit 800	4"/ø100mm	4mm	€ 14,50
	1051500	Puma grit 1500	4"/ø100mm	4mm	€ 14,50
	1053500	Puma grit 3500	4"/ø100mm	4mm	€ 14,50
PUMA 5"/ø125mm					
	1270060	Puma grit 60	5"/ø125mm	4mm	€ 19,80
	1270120	Puma grit 120	5"/ø125mm	4mm	€ 19,80
	1270220	Puma grit 220	5"/ø125mm	4mm	€ 19,80
	1270400	Puma grit 400	5"/ø125mm	4mm	€ 19,80
	1270800	Puma grit 800	5"/ø125mm	4mm	€ 19,80
	1271500	Puma grit 1500	5"/ø125mm	4mm	€ 19,80
	1273500	Puma grit 3500	5"/ø125mm	4mm	€ 19,80
PUMA 6"/ø150mm					
	1580060	Puma grit 60	6"/ø150mm	4mm	€ 29,50
	1580120	Puma grit 120	6"/ø150mm	4mm	€ 29,50
	1580220	Puma grit 220	6"/ø150mm	4mm	€ 29,50
	1580400	Puma grit 400	6"/ø150mm	4mm	€ 29,50
	1580800	Puma grit 800	6"/ø150mm	4mm	€ 29,50
	1581500	Puma grit 1500	6"/ø150mm	4mm	€ 29,50
	1583500	Puma grit 3500	6"/ø150mm	4mm	€ 29,50

CYCLON UNIVERSAL series

Manufactured with large, raised segments for long life and high glossy finish. They don't break although the floor is uneven. Long Performance.

CYCLON UNIVERSAL 3"/ø75mm					
	0720060	Cyclon universal grit 60	3"/ø75mm	9mm	€ 14,50
	0720120	Cyclon universal grit 120	3"/ø75mm	9mm	€ 14,50
	0720220	Cyclon universal grit 220	3"/ø75mm	9mm	€ 14,50
	0720400	Cyclon universal grit 400	3"/ø75mm	9mm	€ 14,50
	0720800	Cyclon universal grit 800	3"/ø75mm	9mm	€ 14,50
	0721500	Cyclon universal grit 1500	3"/ø75mm	9mm	€ 14,50
CYCLON UNIVERSAL 4"/ø100mm					
	1020060	Cyclon universal grit 60	4"/ø100mm	9mm	€ 19,50
	1020120	Cyclon universal grit 120	4"/ø100mm	9mm	€ 19,50
	1020220	Cyclon universal grit 220	4"/ø100mm	9mm	€ 19,50
	1020400	Cyclon universal grit 400	4"/ø100mm	9mm	€ 19,50
	1020800	Cyclon universal grit 800	4"/ø100mm	9mm	€ 19,50
	1021500	Cyclon universal grit 1500	4"/ø100mm	9mm	€ 19,50

GRINDING

SINGLE DISC

TOOLS

SPECIAL

VACUUM

CHEMICALS

MARKETING

LYON YELLOW series

Diamond resin disc specially designed for marble.

PICTURE	CODE	NAME	SIZE	THICKNESS	€ each
	LYON YELLOW 3"/ø75mm				
	075743	Lyon yellow grit 60	3"/ø75mm	11mm	€ 17,50
	075744	Lyon yellow grit 120	3"/ø75mm	11mm	€ 17,50
	075745	Lyon yellow grit 220	3"/ø75mm	11mm	€ 17,50
	075746	Lyon yellow grit 400	3"/ø75mm	11mm	€ 17,50
	075747	Lyon yellow grit 800	3"/ø75mm	11mm	€ 17,50
	075748	Lyon yellow grit 1500	3"/ø75mm	11mm	€ 17,50

	LYON YELLOW 4"/ø100mm				
	100743	Lyon yellow grit 60	4"/ø100mm	11mm	€ 28,00
	100744	Lyon yellow grit 120	4"/ø100mm	11mm	€ 28,00
	100745	Lyon yellow grit 220	4"/ø100mm	11mm	€ 28,00
	100746	Lyon yellow grit 400	4"/ø100mm	11mm	€ 28,00
	100747	Lyon yellow grit 800	4"/ø100mm	11mm	€ 28,00
	100748	Lyon yellow grit 1500	4"/ø100mm	11mm	€ 28,00

LEOPARD series

Flexible resin bonded diamond disc designed for universal application.

	LEOPARD 4"/ø100mm				
	1040060	Leopard grit 60	4"/ø100mm	4mm	€ 19,50
	1040120	Leopard grit 120	4"/ø100mm	4mm	€ 19,50
	1040220	Leopard grit 220	4"/ø100mm	4mm	€ 19,50
	1040400	Leopard grit 400	4"/ø100mm	4mm	€ 19,50
	1040800	Leopard grit 800	4"/ø100mm	4mm	€ 19,50
	1041500	Leopard grit 1500	4"/ø100mm	4mm	€ 19,50
1043500	Leopard grit 3500	4"/ø100mm	4mm	€ 19,50	

	LEOPARD 5"/ø125mm				
	1240060	Leopard grit 60	5"/ø125mm	4mm	€ 24,50
	1240120	Leopard grit 120	5"/ø125mm	4mm	€ 24,50
	1240220	Leopard grit 220	5"/ø125mm	4mm	€ 24,50
	1240400	Leopard grit 400	5"/ø125mm	4mm	€ 24,50
	1240800	Leopard grit 800	5"/ø125mm	4mm	€ 24,50
	12401500	Leopard grit 1500	5"/ø125mm	4mm	€ 24,50
12403500	Leopard grit 3500	5"/ø125mm	4mm	€ 24,50	

	LEOPARD 6"/ø150mm				
	1540060	Leopard grit 60	6"/ø150mm	4mm	€ 33,00
	1540120	Leopard grit 120	6"/ø150mm	4mm	€ 33,00
	1540220	Leopard grit 220	6"/ø150mm	4mm	€ 33,00
	1540400	Leopard grit 400	6"/ø150mm	4mm	€ 33,00
	1540800	Leopard grit 800	6"/ø150mm	4mm	€ 33,00
	15401500	Leopard grit 1500	6"/ø150mm	4mm	€ 33,00
15403500	Leopard grit 3500	6"/ø150mm	4mm	€ 33,00	

GRINDING

SINGLE DISC

TOOLS

SPECIAL

VACUUM

CHEMICALS

MARKETING

JUMPER UNIVERSAL series

Diamond resin discs manufactured with large, raised segments for long life and high glossy finish. They don't break although the floor is uneven. Long Performance.

PICTURE	CODE	NAME	SIZE	THICKNESS	€ each
	JUMPER UNIVERSAL 3"/ø75mm				
	0780060	Jumper universal grit 60	3"/ø75mm	11mm	€ 15,50
	0780120	Jumper universal grit 120	3"/ø75mm	11mm	€ 15,50
	0780220	Jumper universal grit 220	3"/ø75mm	11mm	€ 15,50
	0780400	Jumper universal grit 400	3"/ø75mm	11mm	€ 15,50
	0780800	Jumper universal grit 800	3"/ø75mm	11mm	€ 15,50
	0781800	Jumper universal grit 1500	3"/ø75mm	11mm	€ 15,50

	JUMPER UNIVERSAL 4"/ø100mm				
	1080060	Jumper universal grit 60	4"/ø100mm	11mm	€ 22,50
	1080120	Jumper universal grit 120	4"/ø100mm	11mm	€ 22,50
	1080220	Jumper universal grit 220	4"/ø100mm	11mm	€ 22,50
	1080400	Jumper universal grit 400	4"/ø100mm	11mm	€ 22,50
	1080800	Jumper universal grit 800	4"/ø100mm	11mm	€ 22,50
	1081800	Jumper universal grit 1500	4"/ø100mm	11mm	€ 22,50

JUMPER GREEN series

Designed for concrete and terrazzo rich of the cement. Long performance. They don't leave colour marks on the floor!

	JUMPER GREEN 3"/ø75mm				
	075493	Jumper green grit 60	3"/ø75mm	11mm	€ 19,50
	075494	Jumper green grit 120	3"/ø75mm	11mm	€ 19,50
	075495	Jumper green grit 220	3"/ø75mm	11mm	€ 19,50
	075496	Jumper green grit 400	3"/ø75mm	11mm	€ 19,50
	075497	Jumper green grit 800	3"/ø75mm	11mm	€ 19,50
	075498	Jumper green grit 1500	3"/ø75mm	11mm	€ 19,50

	JUMPER GREEN 4"/ø100mm				
	100493	Jumper green grit 60	4"/ø100mm	11mm	€ 29,90
	100494	Jumper green grit 120	4"/ø100mm	11mm	€ 29,90
	100495	Jumper green grit 220	4"/ø100mm	11mm	€ 29,90
	100496	Jumper green grit 400	4"/ø100mm	11mm	€ 29,90
	100497	Jumper green grit 800	4"/ø100mm	11mm	€ 29,90
	100498	Jumper green grit 1500	4"/ø100mm	11mm	€ 29,90

JUMPER YELLOW series

Diamond resin disc specially designed for marble. They don't break although the floor is uneven. Long Performance.

	JUMPER YELLOW 3"/ø75mm				
	0750060	Jumper yellow grit 60	3"/ø75mm	11mm	€ 25,00
	0750120	Jumper yellow grit 120	3"/ø75mm	11mm	€ 25,00
	0750220	Jumper yellow grit 220	3"/ø75mm	11mm	€ 25,00
	0750400	Jumper yellow grit 400	3"/ø75mm	11mm	€ 25,00
	0750800	Jumper yellow grit 800	3"/ø75mm	11mm	€ 25,00
	0751800	Jumper yellow grit 1500	3"/ø75mm	11mm	€ 25,00

	JUMPER YELLOW 4"/ø100mm				
	1000060	Jumper yellow grit 60	4"/ø100mm	11mm	€ 32,50
	1000120	Jumper yellow grit 120	4"/ø100mm	11mm	€ 32,50
	1000220	Jumper yellow grit 220	4"/ø100mm	11mm	€ 32,50
	1000400	Jumper yellow grit 400	4"/ø100mm	11mm	€ 32,50
	1000800	Jumper yellow grit 800	4"/ø100mm	11mm	€ 32,50
	1001800	Jumper yellow grit 1500	4"/ø100mm	11mm	€ 32,50

GRINDING

SINGLE DISC

TOOLS

SPECIAL

VACUUM

CHEMICALS

MARKETING

PANTERA series

Diamond resin discs specially designed with large, raised segments for long life.

PICTURE	CODE	NAME	SIZE	THICKNESS	€ each
---------	------	------	------	-----------	--------



PANTERA 4"/ø100mm

1030030	Pantera grit 30	4"/ø100mm	4mm	€ 24,50
1030060	Pantera grit 60	4"/ø100mm	4mm	€ 24,50
1030120	Pantera grit 120	4"/ø100mm	4mm	€ 24,50
1030220	Pantera grit 220	4"/ø100mm	4mm	€ 24,50
1030400	Pantera grit 400	4"/ø100mm	4mm	€ 24,50
1030800	Pantera grit 800	4"/ø100mm	4mm	€ 24,50
1031500	Pantera grit 1500	4"/ø100mm	4mm	€ 24,50
1033500	Pantera grit 3500	4"/ø100mm	4mm	€ 24,50



PANTERA 5"/ø125mm

1260030	Pantera grit 30	5"/ø125mm	4mm	€ 30,50
1260060	Pantera grit 60	5"/ø125mm	4mm	€ 30,50
1260120	Pantera grit 120	5"/ø125mm	4mm	€ 30,50
1260220	Pantera grit 220	5"/ø125mm	4mm	€ 30,50
1260400	Pantera grit 400	5"/ø125mm	4mm	€ 30,50
1260800	Pantera grit 800	5"/ø125mm	4mm	€ 30,50
12601500	Pantera grit 1500	5"/ø125mm	4mm	€ 30,50
12603500	Pantera grit 3500	5"/ø125mm	4mm	€ 30,50



PANTERA 6"/ø150mm

1560030	Pantera grit 30	5"/ø125mm	4mm	€ 30,50
1560060	Pantera grit 60	6"/ø150mm	4mm	€ 41,50
1560120	Pantera grit 120	6"/ø150mm	4mm	€ 41,50
1560220	Pantera grit 220	6"/ø150mm	4mm	€ 41,50
1560400	Pantera grit 400	6"/ø150mm	4mm	€ 41,50
1560800	Pantera grit 800	6"/ø150mm	4mm	€ 41,50
15601500	Pantera grit 1500	6"/ø150mm	4mm	€ 41,50
15603500	Pantera grit 3500	6"/ø150mm	4mm	€ 41,50



GRIMPEUR series

To use before resin discs. They have special bevelled lips that ride over lipages without damaging the floor.



GRIMPEUR 3"/ø75mm

1070030	Grimpeur grit 30	3"/ø75mm	€ 69,00
1070060	Grimpeur grit 60	3"/ø75mm	€ 69,00
1070120	Grimpeur grit 120	3"/ø75mm	€ 69,00



GRIMPEUR 4"/ø100mm

1071030	Grimpeur grit 30	4"/ø100mm	€ 115,00
1071060	Grimpeur grit 60	4"/ø100mm	€ 115,00
1071120	Grimpeur grit 120	4"/ø100mm	€ 115,00

GRINDING

SINGLE DISC

TOOLS

SPECIAL

VACUUM

CHEMICALS

MARKETING

Ready Cool

GRINDING

SINGLE DISC

TOOLS

SPECIAL

VACUUM

CHEMICALS

MARKETING

► **Keep your diamonds cool and increase performance!**



Amortized support

► **“READY COOL” is the new AUTO-COOLING DIAMOND PLATE HOLDER BY KLINDEX®, developed to solve some of the common problems of dry grinding, “the excessive heat of the tool adversely affect the efficiency and performance”.**

Experienced operators know the challenges of maintaining diamond tool performance due to the diamonds heating up excessively. The temperature rise is caused by friction, concentrations of dust under the hood of the planetarium, and accumulation of heat trapped in the hood.

The heat increase makes losing cutting performance and durability of the tool, thanks to the new plate “READY COOL”, which helps to cool the tool during use, the problem is solved!



The new plate holder "Ready Cool" creates a vortex of air around the diamond tools thanks to the SUSPENSION SYSTEM. The air flow generated due to the space between the plate holder cools the diamonds effectively and at the same time, helps the aspiration process of the vacuum to more effectively extract the dust generated during the grinding process.



KEY BENEFITS:

- Longer tool life.
- Dust extraction is more efficient.
- Lower risk of blunting the tools by excessive heat.
- Increase performance of dry grinding.
- Lower operating costs.
- Easy delivery.
- More flexibility to adjust the speed of the grinding performance of the machine by removing or adding diamond segments.
- Same tools for different size machines.

Ready Cool plate holder

UT025201	ø 5,5"/140mm	Levighetor 645	Can fix 3 tools	€ 90,00
UT025301	ø 8"/200mm	Levighetor 650, Expander 530, Hercules 450-451-550-551	Can fix 3 or 6 tools	€ 94,50
UT025401	ø 9,5"/240mm	Expander 1000-850-750-650-580, Levighetor Max, Hercules 800-650-601, Rotoklin 240	Can fix 3 or 6 tools	€ 99,50
UT025501	ø 13,5"/340mm	Expander 950, Hercules 750	Can fix 3 or 6 tools	€ 115,00
UT025601	ø 17"/430mm	Single disc machines	Can fix 3, 6 or 9 tools	n.a.



Quick Lock

GRINDING
SINGLE DISC
TOOLS
SPECIAL
VACUUM
CHEMICALS
MARKETING

Keep your diamonds cool and increase performance!

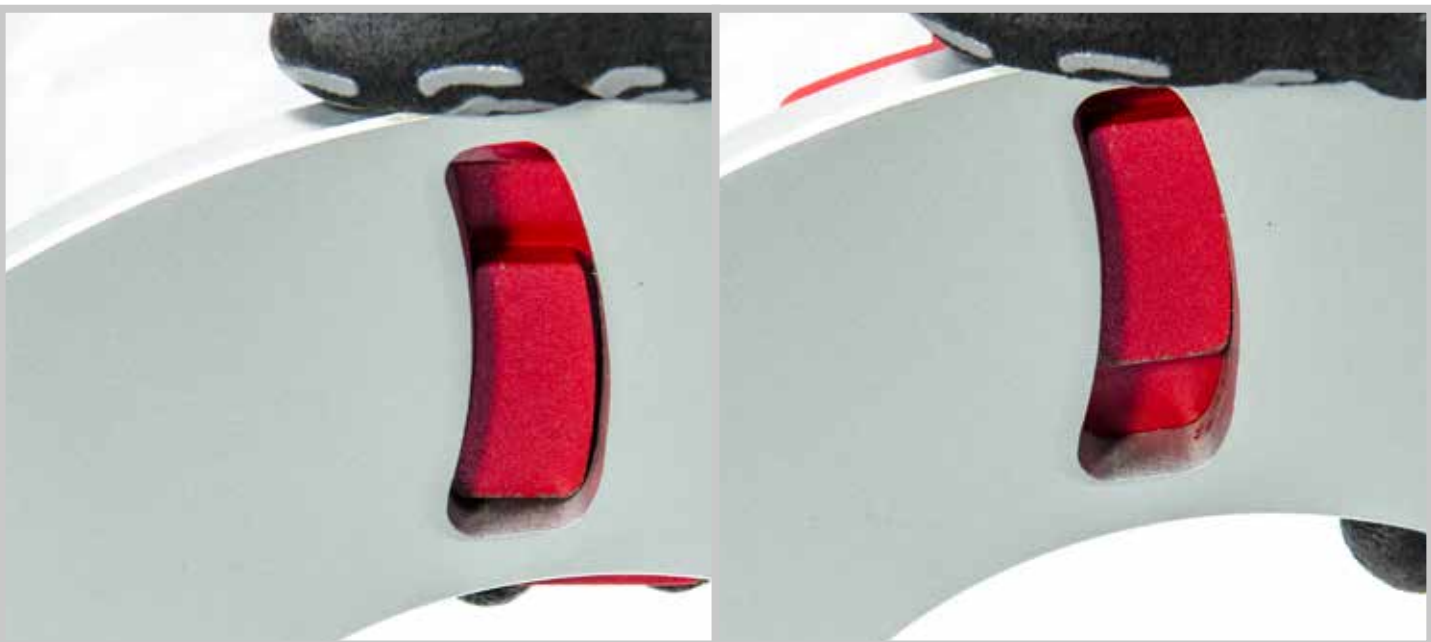

Quick Lock is the new line of diamond tools by Klindex® designed for the new Ready Cool plate. Thanks to the handy curved locking system the Quick Lock diamond pad can be fitted and removed by one simple movement while remaining perfectly anchored when in use.

The Quick Lock can be mounted on any size Ready Cool plate, facilitating the operator that owns multiple machines and will not be obliged to have a number of tools helping to reduce management costs.



“Ready cool” plate holder can be used with Klindex tools “Quick Lock”. Others usage can ‘cause damage or violate any warranty claim.

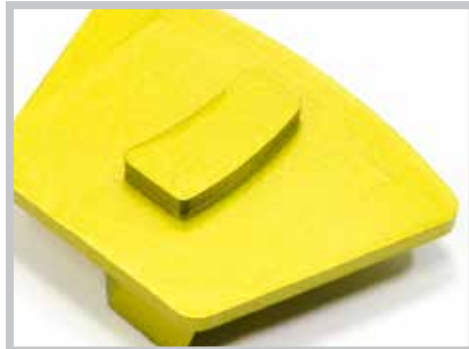

Compact packaging saves delivery costs.



GRINDING

SINGLE DISC

TOOLS

SPECIAL

VACUUM

CHEMICALS

MARKETING



**000 YELLOW
SUPER COARSE**



**00 BLUE
EXTRA COARSE**

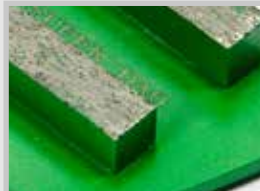

**0 GREEN
COARSE**



**1 RED
MEDIUM**



**2 BLACK
FINE**



SURFACE PREPARATION



DA Quick Lock

Diamond tools for medium abrasive concrete. Cost effective with high efficiency.



DA Quick Lock

700239	DA00 Quick Lock	grit 16/20	2 Segments	€ 58,50
700240	DA0 Quick Lock	grit 30/40	2 Segments	€ 45,80
700241	DA1 Quick Lock	grit 70	2 Segments	€ 45,80
700242	DA2 Quick Lock	grit 140	2 Segments	€ 45,80



DA Quick Lock

700139	DA00 Quick Lock	grit 20	1 segment	€ 38,50
700140	DA0 Quick Lock	grit 40	1 segment	€ 33,50
700141	DA1 Quick Lock	grit 70	1 segment	€ 33,50
700142	DA2 Quick Lock	grit 140	1 segment	€ 33,50

CD Quick Lock

Premium Diamond tools for hard concrete. Not for use on abrasive floors.



CD Quick Lock

700339	CD00 Quick Lock	grit 20	2 Segments	€ 56,50
700340	CD0 Quick Lock	grit 40	2 Segments	€ 49,50
700341	CD1 Quick Lock	grit 70	2 Segments	€ 47,50
700342	CD2 Quick Lock	grit 140	2 Segments	€ 47,50



CD Quick Lock

700439	CD00 Quick Lock	grit 20	1 segment	€ 39,50
700440	CD0 Quick Lock	grit 40	1 segment	€ 38,50
700441	CD1 Quick Lock	grit 70	1 segment	€ 36,50
700442	CD2 Quick Lock	grit 140	1 segment	€ 36,50

CA Quick Lock

Premium quality diamond tools. The most commonly used tools for general surface preparation.



CA Quick Lock

700539	CA00 Quick Lock	grit 16-20	2 Segments	€ 59,50
700540	CA0 Quick Lock	grit 30-40	2 Segments	€ 56,50
700541	CA1 Quick Lock	grit 60-80	2 Segments	€ 52,50
700542	CA2 Quick Lock	grit 120-150	2 Segments	€ 52,50



CA Quick Lock

700535	CA00 Quick Lock	grit 16-20	1 segment	€ 42,50
700536	CA0 Quick Lock	grit 30-40	1 segment	€ 39,50
700537	CA1 Quick Lock	grit 60-80	1 segment	€ 37,50
700538	CA2 Quick Lock	grit 120-150	1 segment	€ 37,50

GRINDING

SINGLE DISC

TOOLS

SPECIAL

VACUUM

CHEMICALS

MARKETING

COATING REMOVAL



GRINDING

SINGLE DISC

BT00 ARROW Quick Lock

THIN RESIN/PAINT REMOVAL ON HARD CONCRETE. Diamond tools with arrow segments with special TCK inserts designed for fast and effective thin resin and paint removal on hard or good substrate cement floors. It does not damage the floor. Not for use on green concrete or abrasive concrete floors.

BT00 Arrow



700836	BT00 Arrow Quick Lock	2 segments	€ 63,50
--------	-----------------------	------------	---------

TOOLS

Skraper PCD Quick Lock

TO REMOVE THICK RUBBERY MATERIAL, EXTREMELY THICK COATING AND PRESSURE SENSITIVE MATERIAL ON THE FLOOR. PCD SKRAPER made up of 1 poly-crystalline diamond skrapper and 1 round diamond with TCK insert and is suggested to remove all types of hard coatings such as: paint, varnish, glue, epoxy, acrylic, screed residue, mastic, black tar adhesive as well as thick rubbery material. Not for use for conventional grinding or for green concrete. It works fast while leaving the surface very rough.

PCD Skrapper Quick Lock



700837	Skraper PCD Quick Lock	1 segments	€ 87,50
--------	------------------------	------------	---------

SPECIAL

Super Skrapper PCD Quick Lock

TO REMOVE THICK RUBBERY MATERIAL, EXTREMELY THICK COATING AND PRESSURE SENSITIVE MATERIAL ON THE FLOOR. PCD SUPER SKRAPER is made up of 2 poly-crystalline diamond and 2 arrow diamond skrapper with TCK insert and is suggested to remove all types of hard coatings such as: paint, varnish, glue, epoxy, acrylic, screed residue, mastic, black tar adhesive as well as thick rubbery material. Not for use for conventional grinding or for green concrete. Compared to PCD SKRAPER it works slower but leaves the surface regularly scratched.

PCD Super Skrapper Quick Lock



700838	Super Skrapper PCD Quick Lock	2 segments	€ 141,50
--------	-------------------------------	------------	----------

VACUUM

BT Quick Lock

Diamond tools with round segments designed for effective grinding and removing resin, glue and varnish. Also suitable for concrete grinding.

BT00 Quick Lock



700959	BT00 Quick Lock	grit 20	2 segments	€ 49,50
--------	-----------------	---------	------------	---------

MARKETING

TCK Quick Lock

LEVELLING, COATING REMOVAL ON GREEN CONCRETE FLOOR. Very tough and hard bond together with special TCK diamond segments, it provides fast and very durable grinding for soft and abrasive concrete. Fast and efficient heavy duty removal of humps, mastics, thin-set, self-levelling compounds and various light coatings on soft concrete floor. For fast removal of various coatings, levelling and grinding soft and very abrasive concrete. Suitable for green concrete, soft and very abrasive concrete with very long lifetime.



TCK Quick Lock

700638	TCK000 Quick Lock		2 segments	€ 75,50
700639	TCK00 Quick Lock		2 segments	€ 69,50
700640	TCK0 Quick Lock		2 segments	€ 65,50



TCK Quick Lock

700658	TCK000 Quick Lock		1 Segment	€ 49,50
700659	TCK00 Quick Lock		1 Segment	€ 47,50
700660	TCK0 Quick Lock		1 Segment	€ 46,50

CF Quick Lock

Diamond tools for asphalt and very abrasive concrete. Super hard bond.



CF Quick Lock

700739	CF00 Quick Lock	grit 20	2 segments	€ 69,50
700740	CF0 Quick Lock	grit 40	2 segments	€ 65,50

DIAMOND TOOLS FOR POLISHING TERRAZZO AND LIMESTONE



MTS Quick Lock

Diamond tools for travertine, terrazzo, limestone, agglomerate and abrasive marble floors. Wet & dry system.



MTS diamond Tools

700940	MTS0 Quick Lock	grit 40	2 segments	€ 46,50
700941	MTS1 Quick Lock	grit 70	2 segments	€ 46,50
700942	MTS2 Quick Lock	grit 140	2 segments	€ 46,50

X-LINE



**Discovery the advantages
of new "X line" diamond tools:**

- High quality**
- High performance**
- Best value**

X-LINE RESIN DIAMOND TOOLS



JUMPER GREEN X-Line

Diamond resin discs manufactured with raised segments for longer life and a better finish for polished concrete. Can be used wet & dry.

Jumper Green X-Line 3"/ø75mm



075512		Jumper Green 2 X-Line	3"/ø75mm	grit 30	€ 13,50
075513		Jumper Green 3 X-Line	3"/ø75mm	grit 60	€ 13,50
075514		Jumper Green 4 X-Line	3"/ø75mm	grit 120	€ 13,50
075515		Jumper Green 5 X-Line	3"/ø75mm	grit 220	€ 13,50
075516		Jumper Green 6 X-Line	3"/ø75mm	grit 400	€ 13,50
075517		Jumper Green 7 X-Line	3"/ø75mm	grit 800	€ 13,50
075518		Jumper Green 8 X-Line	3"/ø75mm	grit 1500	€ 13,50

Jumper Green X-Line 4"/ø100mm



100512		Jumper Green 2 X-Line	4"/ø100mm	grit 30	€ 19,50
100513		Jumper Green 3 X-Line	4"/ø100mm	grit 60	€ 19,50
100514		Jumper Green 4 X-Line	4"/ø100mm	grit 120	€ 19,50
100515		Jumper Green 5 X-Line	4"/ø100mm	grit 220	€ 19,50
100516		Jumper Green 6 X-Line	4"/ø100mm	grit 400	€ 19,50
100517		Jumper Green 7 X-Line	4"/ø100mm	grit 800	€ 19,50
100518		Jumper Green 8 X-Line	4"/ø100mm	grit 1500	€ 19,50

JUMPER YELLOW X-Line

Diamond resin disc specially designed for marble. They don't break although the floor is uneven. Long Performance.

Jumper Yellow X-Line 3"/ø75mm



075533		Jumper Yellow 3 X-Line	3"/ø75mm	grit 60	€ 17,50
075534		Jumper Yellow 4 X-Line	3"/ø75mm	grit 120	€ 17,50
075535		Jumper Yellow 5 X-Line	3"/ø75mm	grit 220	€ 17,50
075536		Jumper Yellow 6 X-Line	3"/ø75mm	grit 400	€ 17,50
075537		Jumper Yellow 7 X-Line	3"/ø75mm	grit 800	€ 17,50
075538		Jumper Yellow 8 X-Line	3"/ø75mm	grit 1500	€ 17,50

Jumper Yellow X-Line 4"/ø100mm



100533		Jumper Yellow 3 X-Line	4"/ø100mm	grit 60	€ 24,50
100534		Jumper Yellow 4 X-Line	4"/ø100mm	grit 120	€ 24,50
100535		Jumper Yellow 5 X-Line	4"/ø100mm	grit 220	€ 24,50
100536		Jumper Yellow 6 X-Line	4"/ø100mm	grit 400	€ 24,50
100537		Jumper Yellow 7 X-Line	4"/ø100mm	grit 800	€ 24,50
100538		Jumper Yellow 8 X-Line	4"/ø100mm	grit 1500	€ 24,50

GRINDING

SINGLE DISC

TOOLS

SPECIAL

VACUUM

CHEMICALS

MARKETING

JUMPER UNIVERSAL X-Line

Diamond resin discs manufactured with large, raised segments for long life and high glossy finish. They don't break although the floor is uneven. Long Performance.

GRINDING



Jumper Universal X-Line 3"/ø75mm

075523	●	Jumper Universal 3 X-Line	3"/ø75mm	grit 60	€ 13,50
075524	●	Jumper Universal 4 X-Line	3"/ø75mm	grit 120	€ 13,50
075525	●	Jumper Universal 5 X-Line	3"/ø75mm	grit 220	€ 13,50
075526	●	Jumper Universal 6 X-Line	3"/ø75mm	grit 400	€ 13,50
075527	●	Jumper Universal 7 X-Line	3"/ø75mm	grit 800	€ 13,50
075528	●	Jumper Universal 8 X-Line	3"/ø75mm	grit 1500	€ 13,50

SINGLE DISC



Jumper Universal X-Line 4"/ø100mm

100523	●	Jumper Universal 3 X-Line	4"/ø100mm	grit 60	€ 19,50
100524	●	Jumper Universal 4 X-Line	4"/ø100mm	grit 120	€ 19,50
100525	●	Jumper Universal 5 X-Line	4"/ø100mm	grit 220	€ 19,50
100526	●	Jumper Universal 6 X-Line	4"/ø100mm	grit 400	€ 19,50
100527	●	Jumper Universal 7 X-Line	4"/ø100mm	grit 800	€ 19,50
100528	●	Jumper Universal 8 X-Line	4"/ø100mm	grit 1500	€ 19,50

KONDOR GREEN X-Line

Diamond resin discs manufactured with raised segments for longer life and a better finish for polished concrete. Can be used wet & dry.

TOOLS



Kondor Green X-Line 3"/ø75mm

075542	●	Kondor Green 2 X-Line	3"/ø75mm	grit 30	€ 14,90
075543	●	Kondor Green 3 X-Line	3"/ø75mm	grit 60	€ 14,90
075544	●	Kondor Green 4 X-Line	3"/ø75mm	grit 120	€ 14,90
075545	●	Kondor Green 5 X-Line	3"/ø75mm	grit 220	€ 14,90
075546	●	Kondor Green 6 X-Line	3"/ø75mm	grit 400	€ 14,90
075547	●	Kondor Green 7 X-Line	3"/ø75mm	grit 800	€ 14,90
075548	●	Kondor Green 8 X-Line	3"/ø75mm	grit 1500	€ 14,90

SPECIAL



Kondor Green X-Line 4"/ø100mm

100542	●	Kondor Green 2 X-Line	4"/ø100mm	grit 60	€ 20,90
100543	●	Kondor Green 3 X-Line	4"/ø100mm	grit 60	€ 20,90
100544	●	Kondor Green 4 X-Line	4"/ø100mm	grit 120	€ 20,90
100545	●	Kondor Green 5 X-Line	4"/ø100mm	grit 220	€ 20,90
100546	●	Kondor Green 6 X-Line	4"/ø100mm	grit 400	€ 20,90
100547	●	Kondor Green 7 X-Line	4"/ø100mm	grit 800	€ 20,90
100548	●	Kondor Green 8 X-Line	4"/ø100mm	grit 1500	€ 20,90

VACUUM

LYON UNIVERSAL X-Line

Diamond resin discs manufactured with large, raised segments for long life and high glossy finish. They don't break although the floor is uneven. Long Performance.

CHEMICALS



Lyon Universal X-Line 3"/ø75mm

075643	●	Lyon Universal 3	3"/ø75mm	grit 60	€ 13,50
075644	●	Lyon Universal 4	3"/ø75mm	grit 120	€ 13,50
075645	●	Lyon Universal 5	3"/ø75mm	grit 220	€ 13,50
075646	●	Lyon Universal 6	3"/ø75mm	grit 400	€ 13,50
075647	●	Lyon Universal 7	3"/ø75mm	grit 800	€ 13,50
075648	●	Lyon Universal 8	3"/ø75mm	grit 1500	€ 13,50

MARKETING



Lyon Universal X-Line 4"/ø100mm

100643	●	Lyon Universal 3	4"/ø100mm	grit 60	€ 19,50
100644	●	Lyon Universal 4	4"/ø100mm	grit 120	€ 19,50
100645	●	Lyon Universal 5	4"/ø100mm	grit 220	€ 19,50
100646	●	Lyon Universal 6	4"/ø100mm	grit 400	€ 19,50
100647	●	Lyon Universal 7	4"/ø100mm	grit 800	€ 19,50
100648	●	Lyon Universal 8	4"/ø100mm	grit 1500	€ 19,50



NEW DIAMOND DISC **X-LINE**

- New formula
- Excellent performance
- Better price

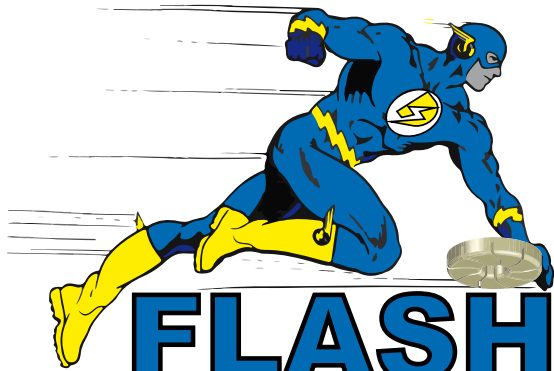

FLASH DIAMOND

Klindex introduces Flash Diamond The new 3 steps polishing system for all marble, terrazzo and concrete surfaces

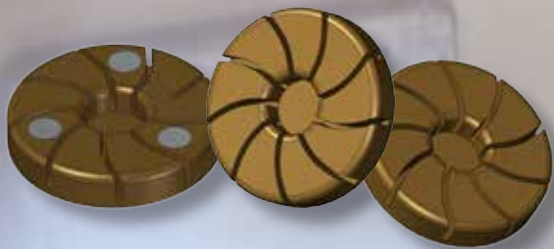

3-STEPS

3 STEPS ONLY FAST POLISHING SYSTEM

Klindex 3 stages system reduces into **only 3 passages the polishing of all pavement** lowering significantly costs and working times Ideal for marble, terrazzo and concrete surfaces they **increase productivity ensuring Klindex' excellent finishing standards.**

- Works both wet and dry • Fit all machines • Available in all sizes • Made in Italy

Advantages:

- ✓ Floor polishing in 3 steps only.
- ✓ Usable both wet and dry.
- ✓ Easy removal of grouting.
- ✓ Flawless finishing.
- ✓ Less time.
- ✓ Higher productivity compared to similar products.
- ✓ Easy to use also for beginners.
- ✓ Reduced labour costs for m².
- ✓ Reduced warehousing costs.
- ✓ Extremely fast system from the first to the last step.

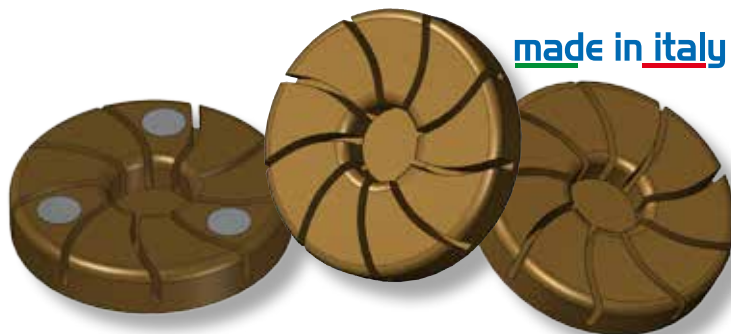

The 3 Steps Of Klindex Flash Diamond

STAGE 1 **Flash Diamond 1** starting tool has been designed to remove simple gaps and minor scratches even on the hardest surfaces. Its hybrid composition allows to remove easily also grouting excesses and prepares the surface for the following steps.

STAGE 2 **Flash Diamond 2** tool is an hybrid disc that makes the surface uniform and ready for the final phase.

STAGE 3 **Flash Diamond 3** final tool gives the surface extraordinary brightness and finishing.

Flash Diamond 3"/ø75mm					
075901VEL	Flash Diamond 1	3"/ø75mm	Step 1		€ 67,50
075902VEL	Flash Diamond 2	3"/ø75mm	Step 2		€ 22,50
075903VEL	Flash Diamond 3	3"/ø75mm	Step 3		€ 22,50

Flash Diamond 4"/ø100mm					
140901VEL	Flash Diamond 1	4"/ø100mm	Step 1		€ n.a.
140902VEL	Flash Diamond 2	4"/ø100mm	Step 2		€ n.a.
140903VEL	Flash Diamond 3	4"/ø100mm	Step 3		€ n.a.

GRINDING

SINGLE DISC

TOOLS

SPECIAL

VACUUM

CHEMICALS

MARKETING

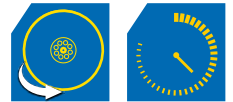

GRINDING
SINGLE DISC
TOOLS
SPECIAL
VACUUM
CHEMICALS
MARKETING

Grinding and polishing machine for WALLS AND VERTICAL SURFACES with built-in vacuum system.



VERTIKA IS ANOTHER KLINDEX EXCLUSIVE. It is the only machine in the world that cleans and polishes vertical surfaces!!! It is also ideal for walls, columns, stairs, bathrooms, kitchens, counter tops etc. It has a variable speed from 0-1000 RPM and it can work both wet and dry. Thanks to its incorporated vacuum system there is no dust or splashing.

*Complete With: Tank, Vacuum System, 5 mt pipe, Kit pad holder, handle.



EASY KIT VERTIKA - set of jaguar flex from grit 30 up to grit 3500, Abrasive Floor Pad White, Green, Black and Red in a duty inox trolley box. (The easy kit does not include grinding head).

EASYKITVTK 100	EASY KIT Marble and Granite	ø100mm	€ 460,00
EASYKITVTK 125	EASY KIT Marble and Granite	ø125mm	€ 530,00
EASYKITVTK 150	EASY KIT Marble and Granite	ø150mm	€ 710,00
EASYKITVTK 165	EASY KIT Marble and Granite	ø165mm	€ 760,00

TECHNICAL DATA

Model	Motor Watt max	Volt	Hertz	Speed Tools	Dimensions tools	Water Tank	Waste Tank	Dimensions WxHxD cm	Weight	Price
VERTIKA CPL	1900	220	50/60	0-1000 rpm	100/150/240mm (4/6/9,5")	20 l	27 l	118x81x57	55 kg	€ 5.795,00
VERTIKA CPL USA	1900	110	60	0-1000 rpm	100/150/240mm (4/6/9,5")	20 l	27 l	118x81x57	55 kg	€ 5.795,00

DATA FOR SHIPPING

Vol. Packaging	Size Packaging	Weight
0,72 m³	120x80x75 cm	94 Kg



JAGUAR FLEX 4"/ø100mm



1000030JA	Jaguar Flex grit 30	4"/ø100mm	4mm	€ 29,50
1000060JA	Jaguar Flex grit 60	4"/ø100mm	4mm	€ 29,50
1000120JA	Jaguar Flex grit 120	4"/ø100mm	4mm	€ 29,50
1000220JA	Jaguar Flex grit 220	4"/ø100mm	4mm	€ 29,50
1000400JA	Jaguar Flex grit 400	4"/ø100mm	4mm	€ 29,50
1000800JA	Jaguar Flex grit 800	4"/ø100mm	4mm	€ 29,50
1001800JA	Jaguar Flex grit 1500	4"/ø100mm	4mm	€ 29,50
1003500JA	Jaguar Flex grit 3500	4"/ø100mm	4mm	€ 29,50

JAGUAR FLEX 5"/ø125mm



1250030JA	Jaguar Flex grit 30	5"/ø125mm	4mm	€ 36,50
1250060JA	Jaguar Flex grit 60	5"/ø125mm	4mm	€ 36,50
1250120JA	Jaguar Flex grit 120	5"/ø125mm	4mm	€ 36,50
1250220JA	Jaguar Flex grit 220	5"/ø125mm	4mm	€ 36,50
1250400JA	Jaguar Flex grit 400	5"/ø125mm	4mm	€ 36,50
1250800JA	Jaguar Flex grit 800	5"/ø125mm	4mm	€ 36,50
1251800JA	Jaguar Flex grit 1500	5"/ø125mm	4mm	€ 36,50
1253500JA	Jaguar Flex grit 3500	5"/ø125mm	4mm	€ 36,50

JAGUAR FLEX 6"/ø150mm

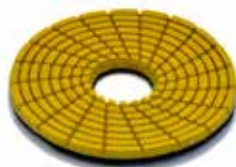

1500030JA	Jaguar Flex grit 30	6"/ø150mm	4mm	€ 59,00
1500060JA	Jaguar Flex grit 60	6"/ø150mm	4mm	€ 59,00
1500120JA	Jaguar Flex grit 120	6"/ø150mm	4mm	€ 59,00
1500220JA	Jaguar Flex grit 220	6"/ø150mm	4mm	€ 59,00
1500400JA	Jaguar Flex grit 400	6"/ø150mm	4mm	€ 59,00
1500800JA	Jaguar Flex grit 800	6"/ø150mm	4mm	€ 59,00
1501800JA	Jaguar Flex grit 1500	6"/ø150mm	4mm	€ 59,00
1503500JA	Jaguar Flex grit 3500	6"/ø150mm	4mm	€ 59,00

JAGUAR FLEX 6,5"/ø165mm



1650030JA	Jaguar Flex grit 30	6,5"/ø165mm	4mm	€ 65,00
1650060JA	Jaguar Flex grit 60	6,5"/ø165mm	4mm	€ 65,00
1650120JA	Jaguar Flex grit 120	6,5"/ø165mm	4mm	€ 65,00
1650220JA	Jaguar Flex grit 220	6,5"/ø165mm	4mm	€ 65,00
1650400JA	Jaguar Flex grit 400	6,5"/ø165mm	4mm	€ 65,00
1650800JA	Jaguar Flex grit 800	6,5"/ø165mm	4mm	€ 65,00
1651800JA	Jaguar Flex grit 1500	6,5"/ø165mm	4mm	€ 65,00
1653500JA	Jaguar Flex grit 3500	6,5"/ø165mm	4mm	€ 65,00

ML FLEXIBLE 9,5"/ø240mm



240001	ML 1	9,5"/ø240mm	4mm	€ 225,00
240002	ML 2	9,5"/ø240mm	4mm	€ 98,00
240003	ML 3	9,5"/ø240mm	4mm	€ 98,00
240004	ML 4	9,5"/ø240mm	4mm	€ 98,00
240005	ML 5	9,5"/ø240mm	4mm	€ 98,00
240006	ML 6	9,5"/ø240mm	4mm	€ 98,00
240007	ML 7	9,5"/ø240mm	4mm	€ 98,00
240008	ML 8	9,5"/ø240mm	4mm	€ 98,00

ML FLEXIBLE 6"/ø150mm



00971	ML 1	6"/ø150mm	4mm	€ 199,00
00972	ML 2	6"/ø150mm	4mm	€ 59,00
00973	ML 3	6"/ø150mm	4mm	€ 59,00
00974	ML 4	6"/ø150mm	4mm	€ 59,00
00975	ML 5	6"/ø150mm	4mm	€ 59,00
00976	ML 6	6"/ø150mm	4mm	€ 59,00
00977	ML 7	6"/ø150mm	4mm	€ 59,00
00978	ML 8	6"/ø150mm	4mm	€ 59,00

ACCESSORIES FOR VERTIKA

PICTURE	CODE	NAME	SIZE	MACHINE	€ each
FLOOR PAD					
	30046	Discolux	4"/ø100mm		€ 4,10
	30066	Discolux	6"/ø150mm		€ 4,90
	30041	White Pad	4"/ø100mm		€ 3,90
	30061	White Pad	6"/ø150mm		€ 4,50
	30042	Green Pad	4"/ø100mm		€ 3,90
	30062	Green Pad	6"/ø150mm		€ 4,50
	30043	Black Pad	4"/ø100mm		€ 3,90
	30063	Black Pad	6"/ø150mm		€ 4,50

PICTURE	CODE	NAME	SIZE	MACHINE	€ each
KIT PAD HOLDER					
	UT5001	Kit Pad Holder	4"/ø100mm		€ 92,00
	UT012101	Kit Pad Holder	5"/ø125mm		€ 125,00
	UT5101	Kit Pad Holder	6"/ø150mm		€ 113,00
	UT012001	Kit Pad Holder	6,5"/ø165mm		€ 130,00
	UT5201	Kit Pad Holder	9,5"/ø240mm		€ 155,00

PICTURE	CODE	NAME	SIZE	MACHINE	€ each
KIT BUSH HAMMER					
To make anti-slip surfaces on stairs.					
	UT5401	Complete of rollers			€ 1.450,00
	45031	Roller spare part			€ 185,00

PICTURE	CODE	NAME	SIZE	MACHINE	€ each
BRUSHES					
	10002	Nylon	4"/ø100mm		€ 59,00
	15002	Nylon	6"/ø150mm		€ 65,00
	24002	Nylon	9,5"/ø240mm		€ 98,00
	15005	Soft Nylon	6"/ø150mm		€ 49,00
	24005	Soft Nylon	9,5"/ø240mm		€ 70,00
	10004	Winnex	4"/ø100mm		€ 70,00
	15004	Winnex	6"/ø150mm		€ 79,80
	24004	Winnex	9,5"/ø240mm		€ 120,00

PICTURE	CODE	NAME	SIZE	MACHINE	€ each
"GRAVITY FREE" KIT					
Gravity free kit for Vertika. Adjustable height up to 3 meters.					
	TE022301	Gravity free kit			€ 1.950,00



GRINDING

SINGLE DISC

TOOLS

SPECIAL

VACUUM

CHEMICALS

MARKETING



VERTIKA

The only grinding and polishing machine for walls and vertical surfaces.



Waterfire



New Edge and Corners MULTI FEATURES Hand Grinder

- The Unique in the Worldwide, with adjustable head
- IP 54 Water and Dust proof

GRINDING

SINGLE DISC

TOOLS

SPECIAL

VACUUM

CHEMICALS

MARKETING



WaterFire Top includes: Back Spherical wheels with independent adjusting, protective sucking cap 125mm, splashguard 125mm, soft platorello 125mm, adjustable head with spherical guides.

WaterFire Top VS includes: Back Spherical wheels with independent adjusting, protective sucking cap 125mm, splashguard 125mm, soft platorello 125mm, adjustable head with spherical guides, variable speed.

Led light and other accessories are optional.



Hand grinder with adjustable head, for corners, Edges, Countertops, skirtings, stairs, for bush-hammer stairs and small surfaces and for open the joints.

WaterFire is the ideal machine to achieve a perfect grinding of natural stones, concrete, wood and a perfect polishing of countertops, shelves, tables and narrow areas. It can be used as a edge grinder, as well as a stairs bush-hammer and as a joint chaser thanks to its extra accessories. **Main Features:** • The only hand grinder with IP54 Protection in the World. • Exceptional asynchronous motor strength, compared to a traditional motor it lasts longer thanks to the protection from external agents like water or dust. • Oversized Gears and bearings, compared to a traditional hand grinder. • Spherical wheels to achieve a perfectly flat surface (to avoid the wave effect). • Front led light to check the working area. • Rotating head feature, for Joint chasing application. • Variable Speed. • Wet or Dry grinding operation (equipped of a water nozzle).

TECHNICAL DATA

Model	Motor	Volt	Hertz	Speed Tools	Dimensions tools	Dimensions WxHxD cm	Weight	Price
WATERFIRE TOP VS Adjustable head	750 Watt	220/110	50/60	500-1600 rpm	125/150mm (5/6")	45x33x23	10 kg	€ 2.650,00

DATA FOR SHIPPING

Vol. Packaging	Size Packaging	Weight
0,10 m ³	45x45x50 cm	20 Kg



Wet and Dry grinding operation.



Wood Sanding.



Grinding and polishing perimeters and edges.

PICTURE	CODE	NAME	SIZE	TYPE	€ each
---------	------	------	------	------	--------



JAGUAR FLEX 5"/ø125mm

1250030JA	Jaguar Flex Grit 30	5"/ø125mm	4mm	€ 36,50
1250060JA	Jaguar Flex Grit 60	5"/ø125mm	4mm	€ 36,50
1250120JA	Jaguar Flex Grit 120	5"/ø125mm	4mm	€ 36,50
1250220JA	Jaguar Flex Grit 220	5"/ø125mm	4mm	€ 36,50
1250400JA	Jaguar Flex Grit 400	5"/ø125mm	4mm	€ 36,50
1250800JA	Jaguar Flex Grit 800	5"/ø125mm	4mm	€ 36,50
1251800JA	Jaguar Flex Grit 1500	5"/ø125mm	4mm	€ 36,50
1253500JA	Jaguar Flex Grit 3500	5"/ø125mm	4mm	€ 36,50

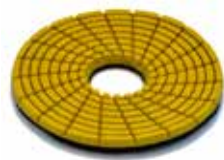

JAGUAR FLEX 6"/ø150mm

1500030JA	Jaguar Flex Grit 30	6"/ø150mm	4mm	€ 59,00
1500060JA	Jaguar Flex Grit 60	6"/ø150mm	4mm	€ 59,00
1500120JA	Jaguar Flex Grit 120	6"/ø150mm	4mm	€ 59,00
1500220JA	Jaguar Flex Grit 220	6"/ø150mm	4mm	€ 59,00
1500400JA	Jaguar Flex Grit 400	6"/ø150mm	4mm	€ 59,00
1500800JA	Jaguar Flex Grit 800	6"/ø150mm	4mm	€ 59,00
1501800JA	Jaguar Flex Grit 1500	6"/ø150mm	4mm	€ 59,00
1503500JA	Jaguar Flex Grit 3500	6"/ø150mm	4mm	€ 59,00



GRINDING CUP: Grinding cup for WaterFire.

125DRC	Double Row Grinding cup	5"/ø125mm	€ 115,00
150DRC	Double Row Grinding cup	6"/ø150mm	€ 134,00



GRINDING CUP: Grinding cup for WaterFire.

125PCD	Grinding cup big PCD	5"/ø125mm	€ 179,00
--------	----------------------	-----------	----------



CRACK CHASER: Crack chaser for WaterFire.

125CCL06	Crack chaser	5"/ø125mm	2mm	€ 85,00
150CCL06	Crack chaser	6"/ø150mm	2mm	€ 112,00



DIAMOND DISC - hole 22,22mm

Thickness of 1,6 mm, designed to re-open the joints of the floor before grouting.

125EL4R	Open-Joints	5"/ø125mm	1,6mm	€ 49,50
150EL4R	Open-Joints	6"/ø150mm	1,6mm	€ 77,00



EASY KIT - WATERFIRE - The Kit includes: WaterFire, a set of JaguarFlex gr. 30,60,120,220,400,800,1500,3500 and inox trolley.

366WTF125GKIT	Kit WaterFire 125 Adjustable Head	5"/ø125mm	€ 2.462,00
370WTF125VSGKIT	Kit WaterFire 125 VS Adjustable Head	5"/ø125mm	€ 3.117,00
366WTF150GKIT	Kit WaterFire 150 Adjustable Head	6"/ø150mm	€ 2.510,00
370WTF150VSGKIT	Kit WaterFire 150 VS Adjustable Head	6"/ø150mm	€ 3.165,00



LED LIGHT: Powerful Led light, battery powered with attack magnetized.

UT023801	Led Light WaterFire	€ 142,50
----------	---------------------	----------



SANDPAPER 5"/ø140mm VELCRO BACKED

140024	Sandpaper grit 24	5,5"/ø140mm	€ 66,80
140036	Sandpaper grit 36	5,5"/ø140mm	€ 64,80
140060	Sandpaper grit 60	5,5"/ø140mm	€ 50,75
140080	Sandpaper grit 80	5,5"/ø140mm	€ 42,50
140100	Sandpaper grit 100	5,5"/ø140mm	€ 42,50

GRINDING

SINGLE DISC

TOOLS

SPECIAL

VACUUM

CHEMICALS

MARKETING

GRINDING

PICTURE	CODE	NAME	SIZE	TYPE	€ each
	TOOLS HOLDER KIT: The Kit includes: vacuum hood, platorello and splashguard.				
	45047	Tools holder kit	5"/ø125mm		€ 110,00
	45049	Tools holder kit	6"/ø150mm		€ 115,00

SINGLE DISC

	BUSH-HAMMER KIT				
	UT026001	Vacuum hood kit: vacuum hood, guide for stairs.			€ 295,00
	UT025001	Bush-Hammer kit: vacuum hood, guide for stairs and art. 45044			€ 925,00

TOOLS

	BUSH-HAMMER DISC ø110 - M14				
	45044	Bush-Hammer	4,5"-ø110mm		€ 675,00

SPECIAL

	SANDBLASTING ø110 - M14				
	45046	Sandblasting	4,5"-ø110mm		€ 615,00

VACUUM

	EDGING KIT: The ideal machine for grinding and polishing countertop edges. *The Kit does not include any tool.				
	45041	Edging Kit			€ 995,00

CHEMICALS

	OPEN-JOINTS KIT: With double guide and assisted spring for a perfect cut. *The Kit does not include the machine.				
	45040	Open-joints Kit			€ 385,00

MARKETING

	AMORTIZED TOOLS HOLDER KIT ø140mm The Kit includes: vacuum hood, tools holder and splashguard.				
	UT026701	Tools holder KIT to use ø140mm AS Diamond disc			€ 315,00.

WaterFire



Maximum protection against water and dust.

UFO CounterTop



GRINDING

SINGLE DISC

TOOLS

SPECIAL

VACUUM

CHEMICALS

MARKETING

Portable grinding planetary machine to polish counter tops and stairs.



▶ UFO is a manual planetary polisher for grinding and polishing counter tops, stairs, edges and narrow areas. Thanks to its powerful motor and to the counter-rotating planetary it is possible to grind and to polish marble, granite and concrete. It differs from all the others machines on the market for its robustness and its perfect balance. The speed of the abrasives is studied in order to make the machine stable, easing the grinding and polishing operations. It is supplied with splash guard and connection for vacuum cleaner. Thanks to its accessories, you can transform the Ufo in to a Floor machine for:

- Grinding and polishing stairs.
- Grinding and polishing marble, stones and concrete.
- Sanding wooden floors.
- Making antique finish of marbles, stones and wood.

*Complete of tank, splash guard and kit velcro pad holder.

TECHNICAL DATA

Model	Motor	Volt	Hertz	Speed Tools	Working Width	Tools Size	Water Tank	Dimensions WxHxD cm	Weight	Price
UFO 290 VS	750 Watt	110/220	50/60	330-770 rpm	290mm (11,5")	3x100mm (4")	2 l	37x39x30	26 kg	€ 3.350,00
UFO 330 VS	750 Watt	110/220	50/60	330-770 rpm	330mm (13")	3x140mm (5,5")	2 l	37x39x34	27 kg	€ 3.450,00



DATA FOR SHIPPING		
Vol. Packaging	Size Packaging	Weight
0,15 m ³	45x45x65cm	31 kg



ACCESSORIES FOR UFO

PICTURE	CODE	NAME	SIZE	TYPE	€ each
---------	------	------	------	------	--------

EASY KIT UFO

Complete of: Ufo, Tank, pad holder, complete set of Jaguar Flex from grit 30 to grit 3500 and inox Trolley.



UFOKIT290VS	Kit Ufo 290 Vs				€ 3.995,00
UFOKIT330VS	Kit Ufo 330 Vs				€ 4.450,00

JAGUAR FLEX 4"/ø100mm



100030JA	Jaguar Flex grit 30	4"/ø100mm	4mm	€ 29,50
100060JA	Jaguar Flex grit 60	4"/ø100mm	4mm	€ 29,50
1000120JA	Jaguar Flex grit 120	4"/ø100mm	4mm	€ 29,50
1000220JA	Jaguar Flex grit 220	4"/ø100mm	4mm	€ 29,50
1000400JA	Jaguar Flex grit 400	4"/ø100mm	4mm	€ 29,50
1000800JA	Jaguar Flex grit 800	4"/ø100mm	4mm	€ 29,50
1001800JA	Jaguar Flex grit 1500	4"/ø100mm	4mm	€ 29,50
1003500JA	Jaguar Flex grit 3500	4"/ø100mm	4mm	€ 29,50

JAGUAR FLEX 5,5"/ø140mm

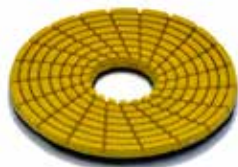

140030JA	Jaguar Flex grit 30	5,5"/ø140mm	4mm	€ 47,00
140060JA	Jaguar Flex grit 60	5,5"/ø140mm	4mm	€ 47,00
1400120JA	Jaguar Flex grit 120	5,5"/ø140mm	4mm	€ 47,00
1400220JA	Jaguar Flex grit 220	5,5"/ø140mm	4mm	€ 47,00
1400400JA	Jaguar Flex grit 400	5,5"/ø140mm	4mm	€ 47,00
1400800JA	Jaguar Flex grit 800	5,5"/ø140mm	4mm	€ 47,00
1401800JA	Jaguar Flex grit 1500	5,5"/ø140mm	4mm	€ 47,00
1403500JA	Jaguar Flex grit 3500	5,5"/ø140mm	4mm	€ 47,00

VELCRO PAD HOLDER



00686	Velcro pad holder	5,5"/ø140mm	UFO 330	€ 25,00
00687	Velcro pad holder	4"/ø100mm	UFO 290	€ 16,00

HANDLES WATER TANK INCLUDED

CM018501CPL	Short Handle with Tank 8lt		UFO 290, UFO 330	€ 595,00
CM018301CPL	Long Handle with Tank 12lt		UFO 290, UFO 330	€ 625,00



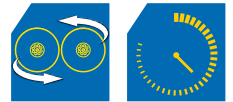

Perimetric grinding and polishing machine with double counter-rotating head.



GRINDING

SINGLE DISC

TOOLS

SPECIAL

VACUUM

CHEMICALS

MARKETING

NO MORE PAIN !! Klindex' patented 360° directional wheels that allow to move the machine in any direction also a long the edges. Ergonomic handle permits standing up working position to avoid back pain and sore knees!
Dust free working. Very balanced thanks counter rotating double disc.

*Complete of water tank, splash guard and velcro baked pad holders.

TECHNICAL DATA

Model	Motor Watt max	Volt	Hertz	Speed Tools	Working Width	Tools Size	Water Tank	Dimensions WxHxD cm	Weight	Price
EXTREMA	1900	110/220	50/60	1000 rpm	304mm (12")	2x146mm (5,7")	8 l	66x101x35	51 kg	€ 3.750,00
EXTREMA VS	1900	110/220	50/60	700-1200 rpm	304mm (12")	2x146mm (5,7")	8 l	66x101x35	60 kg	€ 4.350,00



DATA FOR SHIPPING		
Vol. Packaging	Size Packaging	Weight
0,54 m³	120x60x75 cm	70 kg



ACCESSORIES FOR EXTREMA

DA series

For medium hard concrete. Not for use on abrasive floors. Designed for effective, efficient grinding, Achieve maximum square footage.

PICTURE	CODE	NAME	SIZE	€ each
---------	------	------	------	--------



DA Diamond Tools 5,7''/ø146mm

146719DAEXT	DA00 grit 20	5,7''/ø146mm	€ 128,00
146720DAEXT	DA0 grit 40	5,7''/ø146mm	€ 120,00
146721DAEXT	DA1 grit 60-80	5,7''/ø146mm	€ 120,00
146722DAEXT	DA2 grit 120-150	5,7''/ø146mm	€ 120,00



JAGUAR FLEX GREEN Diamond Tools 5,7''/ø146mm

146303	Jaguar Flex 3 Green	5,7''/ø146mm	€ 39,50
146304	Jaguar Flex 4 Green	5,7''/ø146mm	€ 39,50
146305	Jaguar Flex 5 Green	5,7''/ø146mm	€ 39,50
146306	Jaguar Flex 6 Green	5,7''/ø146mm	€ 39,50
146307	Jaguar Flex 7 Green	5,7''/ø146mm	€ 39,50
146308	Jaguar Flex 8 Green	5,7''/ø146mm	€ 39,50
146309	Jaguar Flex 9 Green	5,7''/ø146mm	€ 39,50

Marble and Terrazzo series

The best diamond tools for polishing marble, terrazzo and stones.



MS Diamond Tools 5,7''/ø146mm

146900EXT	MS0 grit 40	5,7''/ø146mm	€ 146,00
146901EXT	MS1 grit 60-80	5,7''/ø146mm	€ 146,00
146902EXT	MS2 grit 120-150	5,7''/ø146mm	€ 146,00

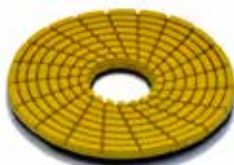

JAGUAR FLEX 5,7''/ø146mm

146322	Jaguar Flex grit 30	5,7''/ø146mm	4mm	€ 49,00
146323	Jaguar Flex grit 60	5,7''/ø146mm	4mm	€ 49,00
146324	Jaguar Flex grit 120	5,7''/ø146mm	4mm	€ 49,00
146325	Jaguar Flex grit 220	5,7''/ø146mm	4mm	€ 49,00
146326	Jaguar Flex grit 400	5,7''/ø146mm	4mm	€ 49,00
146327	Jaguar Flex grit 800	5,7''/ø146mm	4mm	€ 49,00
146328	Jaguar Flex grit 1500	5,7''/ø146mm	4mm	€ 49,00
146329	Jaguar Flex grit 3500	5,5''/ø140mm	4mm	€ 49,00

SPARE PARTS

Main accessories and spare parts for Extrema machine.



VELCRO PAD HOLDER

00684	Soft pad holder with velcro	5,7''/ø146mm	€ 25,00
00683	Hard pad holder with velcro	5,7''/ø146mm	€ 25,00

Baby



Compact and powerful grinding and polishing machine ideal for stairs and narrow areas.



GRINDING

SINGLE DISC

TOOLS

SPECIAL

VACUUM

CHEMICALS

MARKETING

Light and compact floor care machine designed for polishing stairs, bathroom, kitchen and narrow areas. The multidirectional wheels, with adjustable height, allow to easily adjust it to any stair. Pad holders and brushes of size 330mm/(13") or 280mm/(11") are available at customer's choice. The powerful motor of 1,7 HP allows the use Planetary 1000/800 rpm.

*Complete with Water tank and Pad Holder 280 mm.

TECHNICAL DATA



Model	Motor Watt max	Volt	Hertz	Speed	Working Width	Water Tank	Dimensions WxHxD cm	Weight	Price
BABY CPL	1450	110/220	50/60	155 rpm	280/330mm (11/13")	8 l	59x81x29	38 kg	€ 2.255,00



DATA FOR SHIPPING		
Vol. Packaging	Size Packaging	Weight
0,45 m³	60x120x62 cm	49 kg



ACCESSORIES FOR BABY

PICTURE	CODE	NAME	SIZE	THICKNESS	€ each
	EASY PLATE Pad holder for 3 abrasive floor pads and velcro backed diamond discs 5"/ø140mm.				
	280159	Easy Plate 280	11"/ø280mm		€ 76,00
	330159	Easy Plate 330	13"/ø330mm		€ 79,00
	PAD HOLDER BASIC WITHOUT ADAPTER CLUTCH The prices of pad holders does not include the Adapter Clutch. Please specify if you also want the Clutch.				
	526113	Pad Holder 13"	13"/ø330mm	For any machine 13"	€ 52,00
	STANDARD BRUSH WITHOUT ADAPTER CLUTCH - FOR MAINTENANCE The prices of brushes does not include the Adapter Clutch. Please specify if you also want the Clutch. The adapter clutch can be reused when the brush has worn out.				
	626113P1	Nylon Brush	13"/ø330mm	For any machine 13"	€ 42,50
	SOFT BRUSH WITHOUT ADAPTER CLUTCH - FOR CARPET CLEANING The prices of brushes does not include the Adapter Clutch. Please specify if you also want the Clutch. The adapter clutch can be reused when the brush has worn out.				
	626113P3	Soft Brush	13"/ø330mm	For any machine 13"	€ 46,50
	POLISHING BRUSH WITHOUT ADAPTER CLUTCH The prices of brushes does not include the Adapter Clutch. Please specify if you also want the Clutch. The adapter clutch can be reused when the brush has worn out.				
	626113U	Polishing Brush	13"/ø330mm	For any machine 13"	€ 56,50
	HARD BRUSH WITHOUT ADAPTER CLUTCH - FOR HEAVY DUTY CLEANING The prices of brushes does not include the Adapter Clutch. Please specify if you also want the Clutch. The adapter clutch can be reused when the brush has worn out.				
	626113S	Winnex Brush	13"/ø330mm	For any machine 13"	€ 105,00
	MS 11"/ø280mm 12 Segments Metalbond Diamond Tools for Marble and terrazzo grinding.				
	280900	MS0	11"/ø280mm		€ 255,00
	280901	MS1	11"/ø280mm		€ 255,00
	280902	MS2	11"/ø280mm		€ 255,00
	SPLASH GUARD				
	AP3301	Splash Guard	124x10cm	7mm	€ 68,00

GRINDING

SINGLE DISC

TOOLS

SPECIAL

VACUUM

CHEMICALS

MARKETING

MiniPower

Orbital machine. Clean and polish where rotary cleaners cannot work



GRINDING
SINGLE DISC
TOOLS
SPECIAL
VACUUM
CHEMICALS
MARKETING



▶ Minipower is a little machine with a big performance! With its “square” brush it can clean and polish even where the rotary cleaning machines cannot. It’s the ideal solution for stairs, corners, small bathrooms, kitchens and narrow areas.

*MINIPOWER CPL Complete With: tank, long handle, short handle, lateral grip, holding plate 25x12, black white and green cleaning pads 25x12.

*MINIPOWER SHORT Complete With: short handle, holding plate 25x12, black white and green cleaning pads 25x12.

TECHNICAL DATA











Model	Motor	Volt	Hertz	Speed	Working Width	Water Tank	Dimensions WxHxD cm	Weight	Price
MINIPOWER CPL	150 Watt	110/220	50/60	45 osc/s	250x120/310x140mm (10,4x5”/13x5,8”)	8 l	42x110x25	11 kg	€ 1.165,00
MINIPOWER SHORT	150 Watt	110/220	50/60	45 osc/s	250x120/310x140mm (10,4x5”/13x5,8”)	Optional	42x42x25	11 kg	€ 995,00

DATA FOR SHIPPING

Vol. Packaging	Size Packaging	Weight
0,20 m³	40x40x115 cm	15 kg

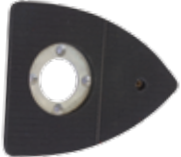

ACCESSORIES FOR MINIPOWER

PICTURE	CODE	NAME	SIZE	TYPE	€ each
	PLATE PAD HOLDER				
	000126	Plate	250x120mm (10,4x5")		€ 48,50
	000129	Plate	310x140mm (13x5,8")		€ 55,00
	ABRASIVE PAD BLACK				
	000217	Black Pad	250x120mm (10,4x5")	Box 10 pcs	€ 44,00
	000216	Black Pad	310x140mm (13x5,8")	Box 10 pcs	€ 49,50
	ABRASIVE PAD WHITE				
	000218	White Pad	250x120mm (10,4x5")	Box 10 pcs	€ 44,00
	000219	White Pad	310x140mm (13x5,8")	Box 10 pcs	€ 49,50
	ABRASIVE PAD GREEN				
	000232	Green Pad	250x120mm (10,4x5")	Box 10 pcs	€ 44,00
	000233	Green Pad	310x140mm (13x5,8")	Box 10 pcs	€ 49,50
	S DIAMOND TOOLS				
	000302	S2	310x140mm (13x5,8")	Box 2 pcs	€ 59,00
	000303	S3	310x140mm (13x5,8")	Box 2 pcs	€ 59,00
	000304	S4	310x140mm (13x5,8")	Box 2 pcs	€ 59,00
	000305	S5	310x140mm (13x5,8")	Box 2 pcs	€ 59,00
	000306	S6	310x140mm (13x5,8")	Box 2 pcs	€ 59,00
	000307	S7	310x140mm (13x5,8")	Box 2 pcs	€ 59,00
	PPL BRUSH				
	000250	PPL Brush	250x120mm (10,4x5")		€ 71,50
	PAD HOLDER DELTA				
	000126D	Delta plate	165x215mm (6,5x8")		€ 48,50
	S DELTA DIAMOND TOOLS				
	000302D	S2 DELTA	165x215mm (6,5x8")		€ 59,00
	000303D	S3 DELTA	165x215mm (6,5x8")		€ 59,00
	000304D	S4 DELTA	165x215mm (6,5x8")		€ 59,00
	000305D	S5 DELTA	165x215mm (6,5x8")		€ 59,00
	000306D	S6 DELTA	165x215mm (6,5x8")		€ 59,00
	000307D	S7 DELTA	165x215mm (6,5x8")		€ 59,00
	KIT SUPERSHINE and SPONGELUX DELTA				
	00300KIT	Complete Kit Supershine	165x215mm (6,5x8")		€ 155,50
	00301DS	Supershine 1 DELTA	165x215mm (6,5x8")		€ 39,50
	00302DS	Supershine 2 DELTA	165x215mm (6,5x8")		€ 39,50
	00303DS	Supershine 3 DELTA	165x215mm (6,5x8")		€ 39,50
	00310	Spongelux	165x215mm (6,5x8")		€ 37,00
	HANDLE				
	000101	Short Handle			€ 78,50

GRINDING

SINGLE DISC

TOOLS

SPECIAL

VACUUM

CHEMICALS

MARKETING

Maxi Quadra

GRINDING
SINGLE DISC
TOOLS
SPECIAL
VACUUM
CHEMICALS
MARKETING

- Ideal for accurate grinding and polishing, flush with the wall and in the corners.
- Grinds, polishes, washes, restores and sands.
- Environmentally friendly: reduces the consumption of water and chemicals.



Maxi Quadra TP
with swinging plate
and big wheels



Maxi Quadra, powerful single-brush floor care machine with 20"/510mm swinging and rectangular plate, is perfect for working on any surface, both with and without water. Thanks to the complete range of tools, Maxi Quadra is a machine suitable for many applications:

- It can be used to restore and thoroughly clean resin, PVC, linoleum and rubber floors, without the need to use chemicals, thus protecting the environment and the health of users.
- Grinds and sands various surfaces such as wood, marble, concrete, reconstructed stone and stone.
- Polishes like a traditional single-brush floor care machine but with the advantage of being able to reach into corners.
- Thanks to the rectangular plate, it is ideal for working under radiators or to reach tight spaces.
- Thanks to the very low level of noise, it is also recommended for sensitive environments such as hospitals, hotels, etc...
- Ensures water-free and completely dust-free operation, thanks to the powerful dedicated extraction kit (optional).

* The price does not include dust extractor, water tank and any other accessories.

TECHNICAL DATA

Model	Motor Watt max	Volt	Hertz	Number of oscillations	Working width	Water Tank	Measurements WxHxD cm	Weight	Price
MAXI QUADRA TP	1900	110/220	50/60	2890 osc/m	360mm x 510mm	12/18 Lt.	51x117x84	42 Kg	€ 3.395,00
MAXI QUADRA TP VS	1900	110/220	50/60	2100-3000 osc/m	360mm x 510mm	12/18 Lt.	51x117x84	42 Kg	€ 3.995,00

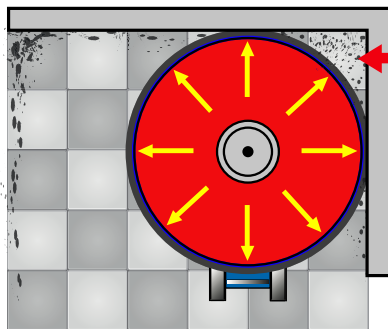
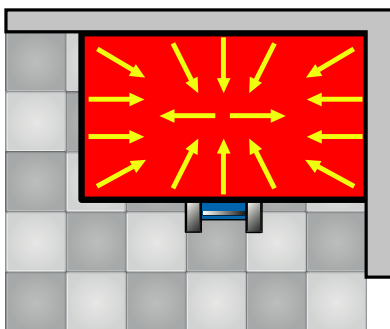

Unlike the circular pad, the rectangular pad reaches corners easily and works evenly flush with the wall.

DATA FOR SHIPPING

Vol. Packaging	Size Packaging	Weight
0,72 m³	120x80x75 cm	85 kg

ACCESSORIES FOR MAXIQUADRA

PICTURE	CODE	NAME	SIZE	€
	FLOOR PADS			
	609361	White Pad	510mm/20"	€ 15,40
	609365	Red Pad	510mm/20"	€ 15,40
	609363	Black Pad	510mm/20"	€ 15,40
	609362	Green Pad	510mm/20"	€ 15,40
	609366	Discolux	510mm/20"	€ 19,50
	SUPERSHINE PLUS			
	604360KIT	KIT Supershine Plus	510mm/20"	n.a.
	604360	Supershine Plus 0	510mm/20"	€ 106,00
	604361	Supershine Plus 1	510mm/20"	€ 106,00
	604362	Supershine Plus 2	510mm/20"	€ 106,00
	604363	Supershine Plus 3	510mm/20"	€ 106,00
	604364	Supershine Plus 4	510mm/20"	€ 106,00
	330110	Spongelux	510mm/20"	€ 126,00
	SUPERSHINE SOFT			
	603360KIT	KIT Supershine Soft	510mm/20"	€ 247,50
	603360	Supershine Soft 0	510mm/20"	€ 49,50
	603361	Supershine Soft 1	510mm/20"	€ 49,50
	603362	Supershine Soft 2	510mm/20"	€ 49,50
	603363	Supershine Soft 3	510mm/20"	€ 49,50
	603364	Supershine Soft 4	510mm/20"	€ 49,50
	KING CONC			
	30909KIT	KIT King Conc	510mm/20"	n.a.
	602359	King Conc 00	510mm/20"	€ 59,50
	30910	King Conc 0	510mm/20"	€ 59,50
	30911	King Conc 1	510mm/20"	€ 59,50
	30912	King Conc 2	510mm/20"	€ 59,50
	602363	King Conc 3	510mm/20"	€ 59,50
	602364	King Conc 4	510mm/20"	€ 59,50
	SANDPAPER			
	510036	Sandpaper grit 36	510mm/20"	€ 19,50
	510060	Sandpaper grit 60	510mm/20"	€ 17,50
	510080	Sandpaper grit 80	510mm/20"	€ 16,50
	510100	Sandpaper grit 100	510mm/20"	€ 16,50
	MESH SCREEN			
	510060R	Mesh Screen grit 60	510mm/20"	€ 12,50
	510080R	Mesh Screen grit 80	510mm/20"	€ 12,50
	510120R	Mesh Screen grit 120	510mm/20"	€ 12,50
	510220R	Mesh Screen grit 220	510mm/20"	€ 12,50

GRINDING

SINGLE DISC





TOOLS

SPECIAL

VACUUM

CHEMICALS

MARKETING

PICTURE	CODE	NAME	SIZE	€
	STRIPPWAX: is a pad designed for removing wax from linoleum, pvc, rubber etc. and for removing varnish from parquet. No needs water and chemical wax stripper.			
	30118	Stripwax	510mm/20"	€ 11,00
MICROFIBRE CLOTHS				
	04232	Microfibre Cloths	510mm/20"	€ 36,50
EXTRACTION KIT				
	AP1201S	Extraction Kit	18 l	€ 795,00
FLUID TANK				
	45000	Fluid tank 12 Lt.		€ 108,50
	SE4501	Fluid tank 18 Lt.		€ 131,00
	EXTRA WEIGHTS 6.5Kg each It can be fitted with up to 4 extra weights.			
	UT80101	Extra Weights		€ 162,00





Perfect grinding in corners and flush with the wall



Works in tight spaces



Cleans and polishes stone and cultured marble floors



before

after

Restores and cleans linoleum, PVC, and rubber



Restores and removes scratches from marble and stone



Polishes concrete floors



Cleans carpets and rugs



Restores and cleans resin and painted floors



GRINDING
SINGLE DISC
TOOLS
SPECIAL
VACUUM
CHEMICALS
MARKETING

Professional wood sanding machine with planetary head

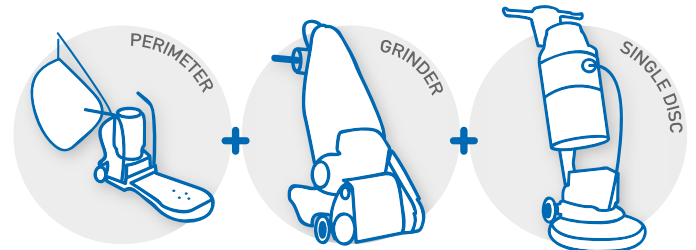
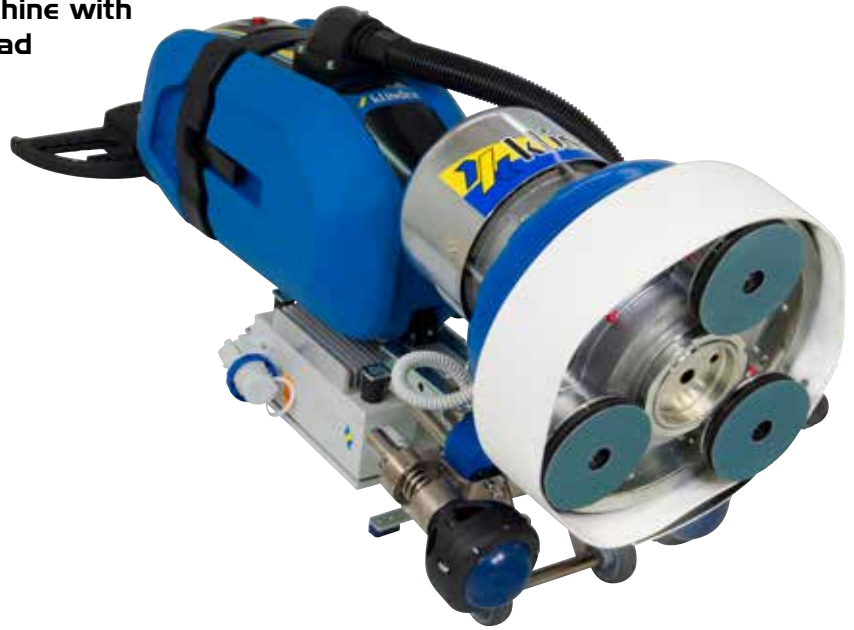

- ▶ TIMBA can do, on any type of wood floor, jobs that traditionally are made with 3 different machines:
- It smooths like a traditional belt sanding machine.
 - It finishes the floor like a mono-brush.
 - It sands up to the skirting borders of the walls like a edge machine. ABSOLUTE PLANARITY. With TIMBA an unrivaled floor planarity can be achieved thanks to its planetary system. The 360° multi-directional wheels allow to move the machine in any direction even very close along the border. Work is FASTER AND COST EFFICIENT!
 - It is easy to use and doesn't need special training like the belt sanding machines.
 - Free of dust thanks to the improved vacuum system.

Complete with: Planetary K800W, directional wheels, transport wheels, vacuum, tuboflex, hood for planetary, hood for pad holder, pad holder 430mm, 3 pcs velcro pad holder 140mm.

TECHNICAL DATA

Model	Motor Watt max	Volt	Hertz	Speed motor	Speed Tools	Working Width	Tools Size	Vacuum Tank	Dimensions WxHxD cm	Weight	Price
TIMBA	2900	220	50/60	155 rpm	800 rpm	450mm	3x140mm (5,5")	18 l	65x135x49	115 kg	€ 5.970,00
TIMBA VS	3000	220	50/60	100-200 rpm	500-1000 rpm	450mm	3x140mm (5,5")	18 l	65x135x49	126 kg	€ 7.570,00



DATA FOR SHIPPING		
Vol. Packaging	Size Packaging	Weight
0,72 m³	80x120x75 cm	150 kg



Ideal to work at the same level of the wall



**TIMBA, for fast and easy sanding
of wooden floors.**

Bella Sander



GRINDING
SINGLE DISC
TOOLS
SPECIAL
VACUUM
CHEMICALS
MARKETING

Professional wood sanding machine with planetary head



***Bella Sander includes:** adjustable wheels, carrying handle, splashguard, K4 wood planetary with 8 pad holders 140mm, pad holder 450mm.
Bella Sander Top includes: adjustable wheels, carrying handle, splashguard, K4 wood planetary with 8 pad holders 140mm, dust control kit, pad holder 450mm.*

Bella is the innovative wood sanding machine born in Klindex home. Available with 2900Watt motor is ideal for cleaning, treatment, grinding and polishing wooden surface. Bella features all the interchangeable accessories to overcome all challenges that occur at construction sites. **Main Features:** • Ergonomically designed handle with hand protection • Sturdy frame, reinforced handle rod • Body carcase in shockproof and scratchproof polyurethane material. • Built in dust vacuum hood. • Centre of the disc water hose release output. • Powerful motors available also with speed controller (VS version). • New compact and modern Made in Italy design • Big wheels for easier transport • Wide range of handle's adjusting positions to permit comfortable working. • Ergonomic carrying handle. • Features the unique K4 planetary system. • High autonomy of water thanks to the 18-liter tank. • Predisposition to the use of dedicated weights. • Power outlet for accessories (optional). • Adjustable height of the wheels. • Led lamp for working in poorly lit environments (optional). • Along the wall grinding • Designed for working also under heaters.

TECHNICAL DATA

Model	Motor Watt max	Volt	Hertz	Speed motor	Working Width	Tools size	Vacuum Tank	Dimensions WxHxD cm	Weight	Price
BELLA SANDER	2900	230	50	140 rpm	450mm (18")	4x140mm	18 l	70x126x50	68 kg	€ 3.995,00
BELLA SANDER VS	2900	230	50	95-165 rpm	450mm (18")	4x140mm	18 l	70x126x50	69 kg	€ 5.595,00
BELLA SANDER TOP	2900	230	50	140 rpm	450mm (18")	4x140mm	18 l	70x126x50	79 kg	€ 4.595,00
BELLA SANDER TOP VS	2900	230	50	95-165 rpm	450mm (18")	4x140mm	18 l	70x126x50	80 kg	€ 6.195,00



Adjustable wheels



Powerful led light

DATA FOR SHIPPING		
Vol. Packaging	Size Packaging	Weight
0,72 m³	80x12x72 cm	92 Kg



Ergonomic handle for an easy transport



New **K4 Planetary**: designed exclusively for the Bella single brush, allows for sanding, grinding and polishing of all stones, concrete and wooden surfaces. It is easy to install, thanks to its quick attach system the operation only takes few seconds. Its "not visible" gears are protected from dirt, sludge and dust guarantee optimum functionality and durability. The 4 rotating heads (140mm) allow to perform even the most demanding sanding jobs with exceptional results in terms of planarity and finish. The outlet at the centre of the planetary K4 reduces the use of water, improves the performance of diamond disks granting working homogeneity. Easy to use, removes the risk of marks on wooden floors and provides a perfectly flat and smooth surface, smooths up to bare wood and flat all unevenness. Smooths along walls allowing to save time and resources. It 'easy to handle even in tight spaces and corners.

Possible applications:

- Grinding and polishing of marble and granite
- Levelling of screeds.
- Grinding and polishing of concrete.
- Sanding of wooden floor and prefinished ones.
- Intermediate wood sanding.
- Grinding and levelling of wood.

Built in dust vacuum hood



Gear protection against dust and slurry

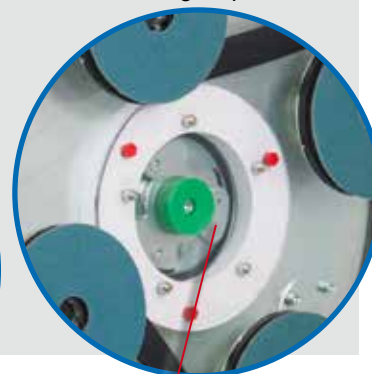

SPLASH GUARD

AP8403 K4 Splash guard € 68,00



WOOD PLANETARY

LU0502LEGNO K4 - 4 heads € 1.565,00



PAD HOLDER

47001 Pad holder 18"Ø450mm € 98,00



EXTRACTION KIT

AP1201S Extraction Kit 18 l € 795,00



EXTRA WEIGHTS KIT - 8,5Kg

CA017502 Extra weight with support € 125,00



LED LIGHT

TE026301 Led light € 333,00

Kroma Sander



GRINDING

SINGLE DISC

TOOLS

SPECIAL

VACUUM

CHEMICALS

MARKETING

Professional planetary sanding machine with integrated dust extraction especially designed for prefinished parquets



DATA FOR SHIPPING		
Vol. Packaging	Size Packaging	Weight
0,72 m ³	80x120x72 cm	81 kg

Ideal for prefinished parquet.

Professional planetary sanding machine with integrated dust extraction especially designed for sanding and restoring of prefinished parquets. Strong and reliable, very powerful with up to 4HP Motor, delivers exceptional results. The wide range of proposed Accessories permit to perform any kind of application on a wide series of surfaces (from parquet to cement substrates, removal of resins and glues)

Main Features: • Base frame in die-cast aluminium. • Strong 3 gears gearbox. • Reinforced handle rod (version 4HP). • Vacuum cleaner with a stellar filter.

*Kroma Sander Includes: Kit dust control, Tuboflex, vacuum guard, Multidisk planetary A3-140AS and Pad Holder for 17" sand paper" and standard pad holder

TECHNICAL DATA									
Model	Motor Watt max	Volt	Hertz	Speed	Working Width	Vacuum Tank	Dimensions WxHxD cm	Weight	Price
KROMA SANDER 18" TOP	2300	220	50/60	150 rpm	450mm (18")	18 l	61x118x45	67 kg	€ 3.790,00
KROMA SANDER 18" TOP	2900	220	50/60	150 rpm	450mm (18")	18 l	61x118x45	72 kg	€ 3.990,00
KROMA SANDER 18" VS TOP	3000	220	50/60	150 - 350 rpm	450mm (18")	18 l	61x118x45	73 kg	€ 5.550,00



Skraper ring



DaOO



Double Sand paper

Maxi Orbit Sander



Roto-Orbital sanding machine with integrated dust extraction



DATA FOR SHIPPING		
Vol. Packaging	Size Packaging	Weight
0,72 m ³	80x120x72 cm	66 kg

Maxi Orbit Sander is the professional, innovative and multi-functional single-brush that makes working on all surfaces quickly and easily. The oscillating head adapts to all surfaces and allows for easy manoeuvres also on uneven surfaces, thereby minimising operator fatigue. Countless accessories available and the large wheels resting on the ground allow for the work to be simple and efficient. Thanks to the roto-orbital principle with high-frequency oscillations, Maxi Orbit is surprising for its excellent stability and manoeuvrability. The robust and compact frame, the ergonomic handle with reinforced rod, the large wheels, the light weight and the release system of the main components (optional) make Maxi Orbit a durable machine but also one that is easy to transport. Thanks to its roto-orbital movement, Maxi Orbit offers excellent performance while simultaneously maintaining great stability and uniquely simple manoeuvrability, a level of quality that allows the machine to also be used by inexperienced operators or others with no particular physical strength. Thanks to the roto-orbital technology you can even work in homes with old electrical systems because the machine consumes less power than a traditional single-brush. Excellent not only for parquet but also for treatments and washing brick, carpet, marble, etc.

TECHNICAL DATA									
Model	Motor Watt max	Volt	Hertz	Speed	Working width	Vacuum tank	Dimensions WxHxD cm	Weight	Price
MAXI ORBIT SANDER 1500	1500	230	50	1400 rpm	430mm (17")	18 lt	70x43x128	40 Kg	€ 2.550,00
MAXI ORBIT SANDER 3000	3000	230	50	1400 rpm	430mm (17")	18 lt	70x43x128	52 Kg	€ 3.195,00



Grinding and sanding parquet



Velcro pad holder with sandpaper



Oil finishing with raised wheels

Futura Sander



GRINDING
SINGLE DISC
TOOLS
SPECIAL
VACUUM
CHEMICALS
MARKETING



Professional sanding machine with Variable Speed motor and integrated dust extraction especially designed for prefinished parquets.



- Ideal for prefinished parquet.**
3HP Variable Speed Motor very noiseless and powerful.
The price includes:
- KIT DUST CONTROL it allows to work "dust free".
 - Pad holder for sand paper ø430mm.
 - Pad Holder standard to use abrasive floor pads.
 - Multidisk A3 - 140AS.

DATA FOR SHIPPING		
Vol. Packaging	Size Packaging	Weight
0,72 m³	80x120x72 cm	70 kg

TECHNICAL DATA									
Model	Motor Watt max	Volt	Hertz	Speed	Working Width	Vacuum Tank	Dimensions WxHxD cm	Weight	Price
FUTURA SANDER 18"	2200	220	50/60	50-450 rpm	450mm (18")	18 l	61x132x45	60 kg	€ 4.695,00



Tytan Ring



Tytan Disc



Double Sand paper

Unika Sander



Professional sanding machine with integrated dust extraction especially designed for prefinished parquets



GRINDING

SINGLE DISC

TOOLS

SPECIAL

VACUUM

CHEMICALS

MARKETING

Ideal for prefinished parquet.

UNIKA SANDER is the ideal floor sanding machine for ordinary maintenance and polishing of wood floor. Strong and very powerful thank to its powerful motor with 1,7 Hp and very strong gear box.

UNIKA SANDER BASIC includes: • kit dust control it allows to work "dust free".

• Pad holder for sand paper ø430mm. • Standard pad holder to use the machine for all other applications.

UNIKA SANDER TOP includes: • kit dust control it allows to work "dust free".

• Pad holder for sand paper ø430mm. • Standard pad holder • Multidisk A3

DATA FOR SHIPPING

Vol. Packaging	Size Packaging	Weight
0,72 m ³	80x120x72 cm	66 kg

TECHNICAL DATA

Model	Motor Watt max	Volt	Hertz	Speed	Working Width	Vacuum Tank	Dimensions WxHxD cm	Weight	Price
UNIKA SANDER 18" BASIC	1450	220	50/60	155 rpm	450mm (18")	18 l	61x132x45	56 kg	€ 2.595,00
UNIKA SANDER 18" TOP	1450	220	50/60	155 rpm	450mm (18")	18 l	61x132x45	56 kg	€ 2.995,00



Tytan Ring



Tytan Disc



Double Sand paper

MiniTimba



Wood sanding machine with twin counter-rotating heads.



Goodbye back pain!

Compact and powerful twin counter-rotating heads sanding machine. It quickly levels very close to the wall, thanks to the two counter-rotating heads which are perfectly balanced, Minitimba is easy to be used even by operators with little experience. Directional wheels drive Minitimba in all directions with the same easiness of a computer mouse. It is ideal for both finishing works and for levelling a screed. Light and easy to carry. Designed to work in tight spaces but its great effectiveness allows to work even in bigger ones. The top handle improves the quality of work allowing to operate in a stand-up position and thanks to the innovative directional and swivel rod, Minitimba is extremely easy to maneuver.

* Complete with central handle, velcro pad holders and dust guard.

TECHNICAL DATA

Model	Motor Watt max	Volt	Hertz	Speed Tools	Working Width	Tools Size	Dimensions WxHxD cm	Weight	Price
MINITIMBA	1300	110/220	50/60	1400 rpm	300mm (12")	2x140mm (5,5")	30x110x63	36 kg	€ 2.995,00
MINITIMBA VS	1300	110/220	50/60	1000-2000 rpm	300mm (12")	2x140mm (5,5")	30x110x63	38 kg	€ 3.495,00

DATA FOR SHIPPING

Vol. Packaging	Size Packaging	Weight
0,58 m ³	60x75x123 cm	45 kg



GRINDING

SINGLE DISC

TOOLS

SPECIAL

VACUUM

CHEMICALS

MARKETING

WE



WOOD



ACCESSORIES FOR WOOD

PICTURE	CODE	NAME	SIZE	€ each
---------	------	------	------	--------

GRINDING
SINGLE DISC
TOOLS
SPECIAL
VACUUM
CHEMICALS
MARKETING



EASY KIT WOOD

Complete kit for Wood.

EASYKITWOOD	Complete kit for Wood.			€ 695,55
140024	Sand paper grit 24	5,5"/ø140mm	Box 30 pcs	included
140036	Sand paper grit 36	5,5"/ø140mm	Box 30 pcs	included
140060	Sand paper grit 60	5,5"/ø140mm	Box 30 pcs	included
140080	Sand paper grit 80	5,5"/ø140mm	Box 30 pcs	included
140100	Sand paper grit 100	5,5"/ø140mm	Box 30 pcs	included
430120R	Mesh Disc grit 120	16"/ø406mm	Box 5 pcs	included
430220R	Mesh Disc grit 220	16"/ø406mm	Box 5 pcs	included
30175	Floor Pad Red	17"/ø430mm	Box 5 pcs	included

PARKET DIAMOND 5,5"/ø140mm 4 Segments

Diamond tools to sand wooden floors



140861AS	Parket Diamond 1	5,5"/ø140mm	K800W, Multidisk 430, K3, K4	€ 145,00
140862AS	Parket Diamond 2	5,5"/ø140mm	K800W, Multidisk 430, K3, K4	€ 145,00

CARBORUNDUM ø406mm (16")

It is an ideal accessory for levelling cement floors.
It eliminates brush marks and surplus materials.



410728	Complete with flange	16"/ø406mm	Timba, Single Discs	€ 230,00
410729	Spare part ring	16"/ø406mm		€ 142,00
410728FUT	Complete with flange	16"/ø406mm	Unika Sander, Futura Sander	€ 230,00
410728BEL	Complete with flange	16"/ø406mm	Bella Sander	€ 230,00

TYTAN RING VIDIA ø440mm (17,5")

Special vidia discs for quick removal of glue and thick resin coatings and for floor preparation.



430170	Complete with flange	Coarse	Timba, Single Discs	€ 298,00
430180	Spare part ring	Coarse		€ 225,00
430171	Complete with flange	Medium	Timba, Single Discs	€ 298,00
430181	Spare part ring	Medium		€ 198,00
430170FUT	Complete with flange	Coarse	Unika Sander, Futura Sander	€ 298,00
430170BEL	Complete with flange	Coarse	Bella Sander	€ 298,00
430171FUT	Complete with flange	Medium	Unika Sander, Futura Sander	€ 298,00
430171BEL	Complete with flange	Medium	Bella Sander	€ 298,00

TYTAN DISK ø430mm (17")

Special vidia discs for quick removal on cement, painted cement, RESIN floors and on foundations. (To use only by Pad Holder SAND PAPER cod.45027).



431112	TYTAN DISK ø 430	Fine	Timba, Single Discs	€ 139,00
431111	TYTAN DISK ø 430	Medium	Timba, Single Discs	€ 139,00
431110	TYTAN DISK ø 430	Coarse	Timba, Single Discs	€ 139,00

DA Diamond Tools 5,5"/ø140mm 5 Segments



140819	DA00 grit 20	5,5"/ø140mm	Levighetor 645	€ 129,00
140820	DA0 grit 40	5,5"/ø140mm	Levighetor 645	€ 98,00
140821	DA1 grit 70	5,5"/ø140mm	Levighetor 645	€ 98,00
140822	DA2 grit 140	5,5"/ø140mm	Levighetor 645	€ 98,00

PICTURE	CODE	NAME	SIZE	MACHINE	€ each
---------	------	------	------	---------	--------



HARD BRUSH WITHOUT ADAPTER CLUTCH - FOR HEAVY DUTY CLEANING

The prices of brushes does not include the Adapter Clutch. Please specify if you also want the Clutch. The adapter clutch can be reused when the brush has worn out.

626117S	Winnex Brush	17"/ø430mm	For any machine 17" and 18"	€ 159,00
---------	--------------	------------	-----------------------------	----------



VELCRO PAD HOLDER

00684	Soft Pad Holder	5,5"/ø140mm	K800W, Multidisk 430, K3, K4	€ 16,50
00683	Hard Pad Holder	5,5"/ø140mm	K800W, Multidisk 430, K3, K4	€ 16,50



DIRECTIONAL WHEELS 360°

CA0405	Kit Directional wheels	360°	Levighetor 600-640-645-650, Timba	€ 755,00
RTO025	Single Sphere		Levighetor 600-640-645-650, Timba	€ 58,00
CA016101	Gasket with sphere		Levighetor 600-640-645-650, Timba	€ 151,00
RTO026	Gasket without sphere		Levighetor 600-640-645-650, Timba	€ 146,00
CA32201	Axle for Directional wheels Kit		Levighetor 600-640-645-650, Timba	€ 32,00



DUST CONTROL KIT

AP6601	Includes vacuum Silurtech, tube and vacuum hood for pad holder.	Levighetor 155, Timba with Pad Holder	€ 860,00
AP6701	Includes vacuum Silurtech, tube and vacuum hood for pad holder.	Levighetor 200 with Pad Holder	€ 860,00
AP6801	Includes vacuum Silurtech, tube and vacuum hood for Planetary with diamond or pavelux.	Levighetor, Timba with Planetary	€ 860,00
AP1201S	Vacuum Silurtech, tube.	Levighetor, Timba, Kroma Sander, Bella Sander, Unika Sander, Futura Sander	€ 795,00



VACUUM HOOD FOR PAD HOLDER

Vacuum hood includes support ring and vacuum guard.

AP2401	Vacuum hood for Pad Holder	Levighetor 200	€ 215,00
AP0201	Vacuum hood for Pad Holder	Levighetor 155, Timba	€ 215,00
AP1902	Vacuum Guard Pad Holder	Levighetor, Timba	€ 68,00
AP1801P	Plastic ring CPL	Levighetor, Timba	€ 155,00
AP022501	Vacuum Guard H 90mm	Levighetor, Timba	€ 98,00



VACUUM HOOD FOR PLANETARY

Vacuum hood includes support ring and vacuum guard.

AP0501NEW	Vacuum hood Planetary (AP1501 + AP2001)	K800W, K1000, K2000	€ 215,00
AP9601	Vacuum hood Planetary	K1200	€ 370,00
AP0501B	Vacuum hood Planetary (AP9401)	K1500	€ 250,00
AP0501C	Vacuum hood Planetary (AP9401)	Planetary with Spring Holder	€ 250,00
AP9701	Vacuum Guard 115X1565mm	K1200	€ 68,00
AP1501	Vacuum Guard 115X1565mm	K1000, K2000, K800W	€ 68,00
AP9501	Vacuum Guard 115X1750mm	K1500	€ 68,00
AP1701	Vacuum Guard 115X1565mm	Planetary with Pavelux or Antike brushes	€ 68,00
AP8403	Rubber Guard K3 and K4	K3, K4 Planetary	€ 68,00

GRINDING

SINGLE DISC

TOOLS

SPECIAL

VACUUM

CHEMICALS

MARKETING

GRINDING

PICTURE	CODE	NAME	SIZE	TYPE	€ each
	SAND PAPER 5,5"/ø140mm VELCRO BACKED				
	140024	Sand paper grit 24	5,5"/ø140mm	Box 30 pcs	€ 66,80
	140036	Sand paper grit 36	5,5"/ø140mm	Box 30 pcs	€ 64,80
	140060	Sand paper grit 60	5,5"/ø140mm	Box 30 pcs	€ 50,75
	140080	Sand paper grit 80	5,5"/ø140mm	Box 30 pcs	€ 42,50
	140100	Sand paper grit 100	5,5"/ø140mm	Box 30 pcs	€ 42,50
	140050C	Ceramic Sand paper grit 50	5,5"/ø140mm	Box 30 pcs	€ 99,00

SINGLE DISC

	DOUBLE SAND PAPER 16,7"/ø425mm				
	430016	Double Sand paper grit 16	16,7"/ø425mm	Timba, Single Discs	€ 22,50
	430024	Double Sand paper grit 24	16,7"/ø425mm	Timba, Single Discs	€ 20,90
	430036	Double Sand paper grit 36	16,7"/ø425mm	Timba, Single Discs	€ 19,50
	430060	Double Sand paper grit 60	16,7"/ø425mm	Timba, Single Discs	€ 10,95

TOOLS

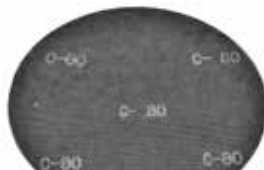
	MESH DISC 16"/ø406mm				
	430060R	Mesh Disc grit 60	16"/ø406mm	Timba, Single Discs	€ 7,35
	430080R	Mesh Disc grit 80	16"/ø406mm	Timba, Single Discs	€ 7,35
	430120R	Mesh Disc grit 100	16"/ø406mm	Timba, Single Discs	€ 7,35
	430220R	Mesh Disc grit 220	16"/ø406mm	Timba, Single Discs	€ 7,35

SPECIAL

	MESH DISC 5,5"/ø140mm				
	140080RVEL	Mesh Disc grit 80	5,5"/ø140mm	Box 30 pcs	€ 46,50
	140120RVEL	Mesh Disc grit 120	5,5"/ø140mm	Box 30 pcs	€ 46,50
	140240RVEL	Mesh Disc grit 240	5,5"/ø140mm	Box 30 pcs	€ 46,50

	PAD HOLDER FOR ABRASIVE SANDPAPERS				
	45027	Pad Holder Sand paper	17"/ø430mm	Single Discs, Levighetor, Timba	€ 122,50
	45027FUT	Pad Holder Sand paper	17"/ø430mm	Futura Sander	€ 122,50
	45027BEL	Pad Holder Sand paper	17"/ø430mm	Bella Sander	€ 122,50
	45027MAXIORB	Pad Holder Sand paper	17"/ø430mm	Maxi Orbit	€152,00

VACUUM

	CLOTHS AND TOOLS				
	2000303	Antistatic cloth	60X22mm	1000pcs	€ 82,00
	1100404	Antistatic cloth tools	60X22mm		€ 36,00

CHEMICALS











ANTIQUE FINISHING



MARKETING

PICTURE	CODE	NAME	SIZE	MACHINE	€ each
	KIT BRUSHES TO ACHIEVE THE ANTIQUE EFFECT ON THE PARQUET				
	14009AS	Steel Brush	5,5"/ø140mm	K800W, Multidisk 430, K3, K4	€ 78,00
	153046	Antike Floor grit 46	5,5"/ø140mm	K800W, Multidisk 430, K3, K4	€ 58,00
	153070	Antike Floor grit 70	5,5"/ø140mm	K800W, Multidisk 430, K3, K4	€ 58,00
	153120	Antike Floor grit 120	5,5"/ø140mm	K800W, Multidisk 430, K3, K4	€ 58,00

PICTURE	CODE	NAME	SIZE	TYPE	€ each
	WOOD KOLLA 60 One component adhesive, based on sililated polymers, for all types of wooden floorings.	042040	Wood Kolla 60	15 Kg	€ 158,00
	WOOD STUKKO K30 Solvent and nmp-free water-based binder to be mixed with sawdust from any type of wood, including merbau, for grouting wooden floors. Suitable for water-based varnishing cycles and Wood Oil.	042058	Wood Stukko K30	5 l	Water based € 49,00
	WOOD NATURAL 10 BASE One-component, rapid-drying, water-based basecoat for preparing wooden floors before applying Wood Natural 11 with low emission of volatile organic compounds and nmp-free.	042050	Wood Natural 10 Base	5 l	Water based € 174,00
	WOOD NATURAL 11 Two-component, water-based, 100% polyurethane varnish with low emission of volatile organic compounds (VOC). Natural, soft finish for protecting wooden floors in residential and commercial environments.	042051	Wood Natural 11	5,5 l	€ 210,00
	WOOD HT 20 BASE Two-component, NMP-free, water-based undercoat with low emission of volatile organic compounds (VOC) and high insulating capacity, for preparing solid and pre-sanded wooden floors and wooden floors under repair for water-based finishing cycles.	042059	Wood HT20 Base	6 l	€ 148,00
	WOOD HT21 Two-component, 100% polyurethane water-based varnish with high resistance to wear and abrasion with low emission of volatile organic compounds (VOC) for wooden floors. Suitable for floors subject to extremely high pedestrian use.	042060	Wood HT21	5,5 l	Water based € 178,00
	WOOD OIL 40 BASE Low-odour urethane oil finish for wooden floors. It can be painted over with the Klindex Wood finishes.	042070	Wood Oil 40 Base	2,5 l	€ 130,00
	WOOD OIL 41 FINISH Natural drying resin oil in water dispersion for finishing wooden floors treated with oil.	042072	Wood Oil 41 Finish	5 l	€ 155,00
	WOOD OIL WAX 50 Water and oil-repellent oil/wax finish with very little odour used to protect wooden surfaces and give them a delicate, warm colour.	042071	Wood Oil Wax 50	2,5 l	€ 124,00

GRINDING

SINGLE DISC

TOOLS

SPECIAL

VACUUM

CHEMICALS

MARKETING

Rafter T - Rafter M



GRINDING

SINGLE DISC

TOOLS

SPECIAL

VACUUM

CHEMICALS

MARKETING



Scraper machine designed for formwork rectification in the precasting industry. Ideal also to remove welding residual, varnish, glue and any hard residual.



Scraper machine designed for formwork rectification in the precasting industry. Ideal also to remove welding residual, varnish, glue and any hard residual. Main characteristics: • 4, 5 or 7 HP single-phase or 3-phase motor. • Working section 400/500/580mm. • Ergonomic and strong handle. • Vacuum hood for perfect dust control.

*Include one set of steel brushes.

TECHNICAL DATA

Model	Motor Watt max	Volt	Hertz	Amp	Speed motor	Speed Tools	Working Width	Tools Size	Water Tank	Dimensions WxHxD cm	Weight	Price
RAFTER 400M	2900	220-240	50/60	--	155 rpm	1000 rpm	400mm (15,5")	3x100mm (4")	18 lt	65x135x43	88 Kg	€ 4.950,00
RAFTER 500M	2900	220-240	50/60	--	155 rpm	1000 rpm	500mm (19,5")	3x200mm (8")	18 lt	65x135x50	88 Kg	€ 5.495,00
RAFTER 500 T	5 HP	380-480	50/60	16	200 rpm	800 rpm	500mm (19,5")	3x200mm (8")	18 lt	95x130x58	130 Kg	€ 5.795,00
RAFTER 580 T	7 HP	380-480	50/60	16	200 rpm	800 rpm	580mm (23")	3x240mm (9,5")	18 lt	95x130x58	160 Kg	€ 7.395,00



DATA FOR SHIPPING

	Vol. Packaging	Size Packaging	Weight
Rafter M	0,45 m³	60x120x62 cm	94 Kg
Rafter T	1,25 m³	120x80x130 cm	175 Kg



RAFTER ACCESSORIES

PICTURE	CODE	NAME	SIZE	MACHINE	€ each
	STEEL BRUSH				
	10009AS	Steel Brush AS	4"/ø100mm	Rafter 400	€ 68,00
	20009RIC	Steel Brush	8"/ø200mm	Rafter 500	€ 75,00
	20009QA	Steel Brush QA	8"/ø200mm	Rafter 500	€ 119,00
	24006RIC	Steel Brush QA	9,5"/ø240mm	Rafter 580	€ 78,00
	STEEL SPIKES				
	20010	Spikes	8"/ø200mm	Rafter 500	€ 88,00
	20010QA	Spikes QA	8"/ø200mm	Rafter 500	€ 149,00
	24010EXP	Spikes QA	9,5"/ø240mm	Rafter 580	€ 155,00
	WINNEX BRUSH grit 120				
	155036AS	Winnex Brush AS	4"/ø100mm	Rafter 400	€ 42,50
	20004	Winnex Brush	8"/ø200mm	Rafter 500	€ 69,00
	20004QA	Winnex Brush QA	8"/ø200mm	Rafter 500	€ 135,00
	24004	Winnex Brush	9,5"/ø240mm	Rafter 580	€ 120,00
	24004QA	Winnex Brush QA	9,5"/ø240mm	Rafter 580	€ 165,00
	ANTIKE FLOOR grit 36				
	155036AS	Antike Floor AS	4"/ø100mm	Rafter 400	€ 42,50
	20036	Antike Floor	8"/ø200mm	Rafter 500	€ 95,00
	20036QA	Antike Floor QA	8"/ø200mm	Rafter 500	€ 155,00
	24036	Antike Floor	9,5"/ø240mm	Rafter 580	€ 185,00
	24036QA	Antike Floor QA	9,5"/ø240mm	Rafter 580	€ 189,00
	PLANETARY MULTIDISK A5 Without brushes.				
	00500	Planetary Multidisk A5	21"/ø530mm	Single Disc 17,18,21"	€ 550,00
	STEEL BRUSH FINE 8" For heavy duty cleaning when the spikes are too aggressive.				
	20009	Steel Brush	8"/ø200mm	Multidisk A5	€ 51,50
	POLISHING BRUSH 8" Polishing brush. Special for terracotta floors.				
	20005	Polishing brush	8"/ø200mm	Multidisk A5	€ 49,00
	DA Diamond Tools 4"/ø100mm 5 Segments				
	100821	DA1 grit 70	4"/ø100mm		€ 95,00
	DA Diamond Tools 8"/ø200mm 6 Segments				
	200821	DA1 grit 70	8"/ø200mm	Lev.650, Herc.450-451-550-551, Exp 530	€ 126,00
	DA Diamond Tools 9,5"/ø240mm 6 Segments				
	240821	DA1 grit 70	9,5"/ø240mm	Rafter 580	€ 135,00

GRINDING

SINGLE DISC

TOOLS

SPECIAL

VACUUM

CHEMICALS

MARKETING

SUPERVAK

Patented System



INDUSTRIAL DUST EXTRACTORS

ASC and SC CLEANING SYSTEMS

VACUUM

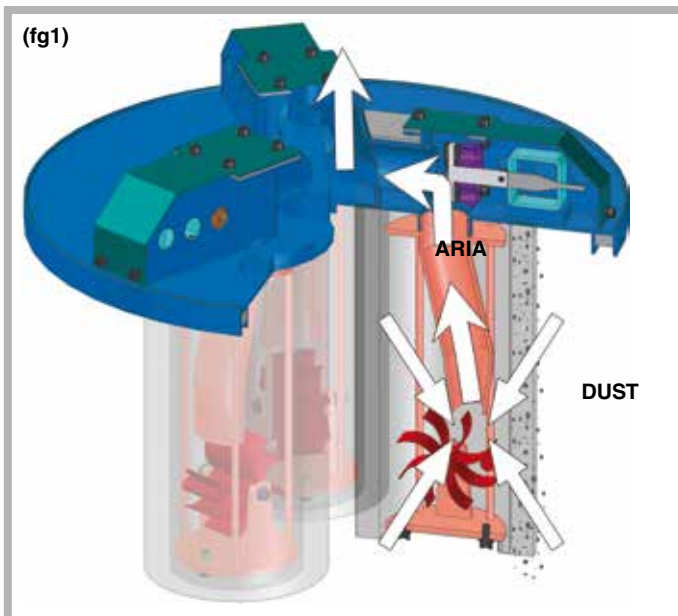

AUTOMATIC SELF-CLEANING

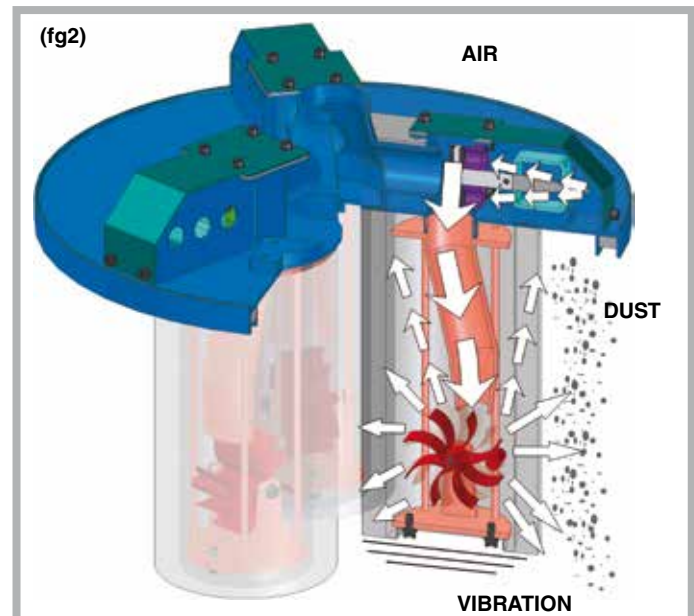

▶ Klindex has developed the new line of SUPERVAK dust collectors, specially designed to handle huge quantity of dust powders without any interruption for the filter blinding. Thanks to the ASC PATENT (Automatic Self Cleaning Filters) the new vacuums allow operators to continuously vacuum also the finest powder without filter troubles. The new dust collectors SUPERVAK series ASC are the only vacuums in the world that, thanks to a "timer connected to the VIBRATION and CONTRA BLOWING patented system" clean the filter at a definite time, automatically, allowing you to work continuously without stopping. In the series SC (Self Cleaning Filter) operating by a simple lever it is possible to automatically clean the filters without removing them.

Main features:

- Patented system to shake and blow the filter at the same time.
- Continuous cleaning: vacuum is always working even during filter cleaning
- Electronic Timer (for ASC models) to control the self cleaning: Cleaning cycles can be modified according to the job and to the vacuum dust.
- Big filter surface thanks to the big cartridge filters.
- Easy removal of the collection tank with the chance (optional) to use normal plastic bags.
- Longopac System (standard on series BAG LINE).
- Robust and long lasting aluminium coated cartridge filters, so that the dust doesn't adhere but slips away.
- Anti-static filters to avoid electrostatic shocks (optional).
- Height-reducing telescopic frame which makes transportation much easier even in normal Vans (models 100, 200, 250).

How the systems works:

The device consists of three filters in cartridge. During vacuum (fig.1), air passes through the filters to the outside. During automatic self-filter cleaning (fig2): At certain intervals (governed by a timer) the machine automatically cleans the filters one at a time. During this phase the intake air is sent inside the filter producing at the same time two effects:

- It starts an eccentric device that will produce a strong vibration effect of the filter.
- Simultaneously it blows the air out off the filter granting a perfect cleaning. During this phase of cleaning a filter the others two filters still work without stopping to vacuum dust.

Supervak 300

GRINDING
SINGLE DISC
TOOLS
SPECIAL
VACUUM
CHEMICALS
MARKETING

HEPA Filter included



► SUPERVAK 300 is the largest of the Supervak vacuums series. The twin in-series pre-separator cyclones greatly reduce the servicing activities of the filters extending their life time. Its great power allows huge continuous air flow and heavy duty operations. Suitable for stationary and mobile use on lines of production or industrial installations. Engineered to aspirate very fine dusts. Available in ASC or SC versions. The RX version is equipped with a wireless remote control to power on or off the vacuum cleaner. It also has a device that automatically corrects the rotation of the motors.

TECHNICAL DATA

Model	Motor	Depress. max mm H ₂ O	Volt	Hertz	Amp	Filter surface cm ²	Air flow max m ³ /h	Noise level dB(A)	Tank capacity	Dimensions WxHxD cm	Weight	Price
SUPERVAK 300 SC	15 kW	2750	380/480	50/60	32	240000	1250	70	140 l	240x230x85	620 kg	n.a.
SUPERVAK 300 ASC	15 kW	2750	380/480	50/60	32	240000	1250	70	140 l	240x230x85	620 kg	n.a.
SUPERVAK 300 ASC RX	15 kW	2750	380/480	50/60	32	240000	1250	70	140 l	240x230x85	620 kg	n.a.



Immediate tank release



Can also be used without cyclones



Height reduction for transport



Powerful, reliable and equipped with twin cyclones pre-separators



Double Independent Turbines



3 big main Filters



Filter cleaning Controls

Supervak 250 Propane

GRINDING
SINGLE DISC
TOOLS
SPECIAL
VACUUM
CHEMICALS
MARKETING

Propane Industrial Dust Extractor



The propane engine makes Klindex SUPERVAK 250 industrial dust collector the most powerful ever built. Kawasaki engine is reliable and sturdy. Perfect to use in combination with big blasting, scarifying or grinding machines. The advanced ASC system allows to keep filters always clean automatically. Large air filtering surface with 3 primary cartridge filters and 2 HEPA secondary filters.

Main advantages: • No limitations due to cables or lack of electric power. • High reliability with Kawasaki engines. • Collapsible frame for easy transportation. • No performance drop and loss of time caused by the power grid. • Free from the hassle and costs of extension cords in the yard. • No need of generator.

Recommended batteries: battery 12V 550 ACC Class.

TECHNICAL DATA

Model	Motor	Power	Propane tank	Depress. max mm H ₂ O	Filter surface cm ²	Air flow max m ³ /h	Tank capacity	Dimensions WxHxD cm	Weight	Price
SUPERVAK 250 Propane	Kawasaki FS603V	12,7KW	9Kg/20lbs	2750	97000	1250	100 lt	154x220x64	342 Kg	€ n.a.



Height reduction for transport



DATA FOR SHIPPING		
Vol. Packaging	Size Packaging	Weight
2,70 m ³	150x80x225 cm	355 Kg



2 additional Hepa filters

Supervak 250

HEPA Filter included



▶ SUPERVAK 250 is equipped with 2 independent Motors 4 kW each for a total power of 8 kW or HP 11 and a large filtering room, it is the ideal dust extractor for efficient vacuuming of large quantities of dust in special industrial applications. Perfect to be connected to big grinder machines like the EXPANDER 1000 or to large scarifiers and shot blasting machines. Available in ASC or SC version. Equipped with various safety systems:

- A vacuum limiter valve ensures the cooling of the engines even in continuative and heavy duty use.
- A pressure indicator allows the monitoring of any malfunctions or filters clogging.
- A Thermal safety switch stops the motors in case of overheating.
- Two secondary filters protect the engine in case of accidental passage of dust through the main filters.

TECHNICAL DATA

Model	Motor	Depress. max mm H ₂ O	Volt	Hertz	Amp	Filter surface cm ²	Air flow max m ³ /h	Noise level dB/(A)	Tank capacity	Dimensions WxHxD cm	Weight	Price
SUPERVAK 250 SC	8 kW	2750	380/480	50/60	16	97000	724	65	100 l	154x220x64	342 kg	€ 16.450,00
SUPERVAK 250 ASC	8 kW	2750	380/480	50/60	16	97000	724	65	100 l	154x220x64	342 kg	€ 17.850,00
SUPERVAK 250 ASC RX	8 kW	2750	380/480	50/60	16	97000	724	65	100 l	154x220x64	342 kg	€ 18.995,00

DATA FOR SHIPPING

Vol. Packaging	Size Packaging	Weight
2,70 m ³	150x80x225 cm	355 kg



Height reduction for transport



2 additional Hepa filters

Supervak 200

GRINDING

SINGLE DISC

TOOLS

SPECIAL

VACUUM

CHEMICALS

MARKETING



HEPA Filter included



► SUPERVAK 200 is the ideal dust collector for all those who have to vacuum big quantities of dust and who have to carry the machine from a place to another. It has been specifically designed to be connected to floor sanders, to grinders, to scarifiers or to shot blasting machines. It is equipped with a telescopic frame which can be used:

- In the “high position” while working to greatly amplify the “cyclone effect” and the filtering power. The higher is the filter chamber, the easier is the separation of dust from the air, resulting in less clogging of filters.
 - In the “low” position for transportation in order to reduce its dimensions and to be easily loaded even in small vans.
- The ASC series is equipped with a control unit with 4 automatic self-cleaning programs that greatly increases the performance of the vacuum cleaner. A secondary filter protects the engine in case of accidental passage of dust through the main filters.

TECHNICAL DATA

Model	Motor	Depress. max mm H ₂ O	Volt	Hertz	Amp	Filter surface cm ²	Air flow max m ³ /h	Tank capacity	Dimensions WxHxD cm	Weight	Price
SUPERVAK 200 T5 ASC	5,5kW	2400	380/480	50/60	16	97000	640	bag	137x203x60	159 Kg	€ 9.650,00
SUPERVAK 200 T5 ASC RX	5,5 kW	2400	380/480	50/60	16	97000	640	bag	137x203x60	159 Kg	€ 11.295,00



Height reduction for transport



DATA FOR SHIPPING		
Vol. Packaging	Size Packaging	Weight
1,26 m ³	120x60x175 cm	179 kg



Control panels

Supervak Oil

separates shavings from oil when cleaning machine tools.



Supervak I44-I55-I75 Oil

Supervak Oil, separates shavings from oil when cleaning machine tools. Industrial vacuum cleaners to recover and separate oil and shavings when cleaning machine tools for mechanical and automotive industries. Supervak Oil vacuum cleaners are designed and built to suction lubricants, coolants, and emulsions mixed with shavings. Inside the collection drum, a filter separates the liquids from the solids, thereby allowing the suctioned oil to be reused, putting it back into the machine tools with obvious economic benefits. New Klindex vacuum cleaners are powerful and reliable, ideal for tank emptying, 5 times more quickly when compared to conventional methods. They also increase the final level of cleanliness and make the operation safer health-wise for the operator.

TECHNICAL DATA

Model	Motor	Depress. max mm H ₂ O	Volt	Hertz	Phases	Blower Type	Air flow max m ³ /h	Liquid capacity	Shaving capacity	Dimensions WxHxD cm	Weight	Price
SUPERVAK 144 OIL	4 kW	2750	230/400	50/60	3F	1ST.	362	60 lt.	40 lt.	107x134x70	118 kg	€ 4795,00
SUPERVAK 155 OIL	5,5 kW	2400	230/400	50/60	3F	2ST.	640	60 lt.	40 lt.	107x147x70	134 kg	€ 5.295,00
SUPERVAK 175 OIL	7,5 kW	3260	230/400	50/60	3F	2ST.	540	60 lt.	40 lt.	107x147x70	140 kg	€ n.a.



Supervak 144-155-175

GRINDING

SINGLE DISC

TOOLS

SPECIAL

VACUUM

CHEMICALS

MARKETING

**Vacuum cleaners
for liquids, solids
and dusts.**



- ▶ Supervak 144-155-175: three-phase vacuum cleaners for liquids, solids and dusts. Like most of Klindex vacuums it finds endless possibilities of application in industrial and professional fields . Vacuum machine with large capacity , power, robustness and reliability, a safe purchase for any company.
- Maintenance free Turbine Engine for 24 hours continuous use.
 - Possibility to vacuuming of dusts, liquids and solids at the same time .
 - Big filtering surface
 - Filter cleaning system with exterior handle
 - Quick release large capacity drum , with bagging possibility

TECHNICAL DATA

Model	Motor	Depress. max mm H ₂ O	Volt	Hertz	Phases	Blower Type	Air flow max m ³ /h	Filter surface cm ²	Tank capacity	Dimensions WxHxD cm	Weight	Price
SUPERVAK 144	4 kW	2750	230/400	50/60	3F	1ST.	362	13900	60 lt.	107x134x70	118 kg	€ 4.495,00
SUPERVAK 155	5,5 kW	2400	230/400	50/60	3F	2ST.	640	13900	60 lt.	107x147x70	134 kg	€ 4.995,00
SUPERVAK 175	7,5 kW	3260	230/400	50/60	3F	2ST.	540	13900	60 lt.	107x147x70	140 kg	€ 5.895,00



Supervak 130-140



Supervak 130 and 140 are vacuum cleaners with industrial 3-phase motors at low cost. Very powerful machine but not big dimension. Excellent for car-washes, small mechanic industry, laboratory etc.

TECHNICAL DATA

Model	Motor	Depress. max mm H ₂ O	Volt	Hertz	Air flow max m ³ /h	Filter surface cm ²	Tank capacity	Noise level dB(A)	IP Protection	Price
SUPERVAK 130	3 kW	2750	230/400	50/60	350	7000	60 lt.	69	54	€ 2.650,00
SUPERVAK 130H	3 kW	2750	230/400	50/60	350	7000	60 lt.	69	54	€ 2.775,00
SUPERVAK 140	4 kW	3150	230/400	50/60	362	7000	60 lt.	69	54	€ 2.850,00
SUPERVAK 140H	4 kW	3150	230/400	50/60	362	7000	60 lt.	69	54	€ 2.995,00



STANDARD for Supervak 130-140 ø 40

Supervak 90 ASC



HEPA Filter included



▶ SUPERVAK 90 is a powerful compact vacuum cleaner to vacuum large quantities of dusts such as: plaster, cement, flour, scabs, sawdust, dust materials from ceramic industry as well as dust produced by sanders, grinders, core drills etc. Available both in ASC version "Automatic Self Cleaning Filter" and in SC version "Self Cleaning Filter". Thanks to ASC and SC patent it can work continuously without having to stop to dismantle and clean the filters (which is an operation that everybody always postpones and nobody would want to do because dusty and annoying). **Main features:**

- ASC or SC system: Automatic and/or Self Cleaning Filter.
- 3 cartridge filters.
- Easily removable tank.
- Possibility to insert a normal plastic bag (optional).
- Secondary filter to protect the motor in case of accidental passage of dust through the main filters.
- Available with single-phase or three-phase motors.

TECHNICAL DATA

Model	Motor	Depress. max mm H ₂ O	Volt	Hertz	Amp	Filter surface cm ²	Air flow max m ³ /h	Tank capacity	Dimensions WxHxD cm	Weight	Price
SUPERVAK 90 SC	2,2 kW	2300	220	50/60	--	32000	350	67 l	88x163x65	130 kg	€ 5.195,00
SUPERVAK 90 ASC	2,2 kW	2300	220	50/60	--	32000	350	67 l	88x163x65	130 kg	€ 6.295,00
SUPERVAK 90 T4 SC	4 kW	2750	380/480	50/60	16	32000	362	67 l	88x163x65	130 kg	€ 5.895,00
SUPERVAK 90 T4 ASC	4 kW	2750	380/480	50/60	16	32000	362	67 l	88x163x65	130 kg	€ 6.895,00



Plastic bag version on request



DATA FOR SHIPPING		
Vol. Packaging	Size Packaging	Weight
1,23 m ³	90x75x182 cm	147 Kg



Control panel

GRINDING

SINGLE DISC

TOOLS

SPECIAL

VACUUM

CHEMICALS

MARKETING

Supervak 90M



HEPA Filter optional



▶ SUPERVAK 90M is a powerful vacuum cleaner with induction motors and Stellar filter. It is recommended for suction of dust, waste processing, iron chippings etc. The mechanical shaking system ensures excellent cleaning and long life of the filter.

Main features:

- Stellar filter.
- Mechanical filter shaking system.
- Easily removable tank.
- Possibility to insert a normal plastic bag (optional).
- Secondary filter to protect the motor.
- Available with single-phase or three-phase motors.
- Hepa filter available on request.

TECHNICAL DATA

Model	Motor	Depress. max mm H ₂ O	Volt	Hertz	Amp	Filter surface cm ²	Air flow max m ³ /h	Tank capacity	Dimensions WxHxD cm	Weight	Price
SUPERVAK 90 M	2,2 kW	2300	220	50/60	--	12000	350	67 lt	88x163x65	129 Kg	€ 3.595,00
SUPERVAK 90 T3 M	3 kW	2450	380/480	50/60	16	12000	362	67 lt	88x163x65	129 Kg	€ 3.860,00
SUPERVAK 90 T4 M	4 kW	2750	380/480	50/60	16	12000	362	67 lt	88x163x65	129 Kg	€ 4.270,00



Mechanical filter shaking system

DATA FOR SHIPPING		
Vol. Packaging	Size Packaging	Weight
1,50 m ³	100x80x185 cm	146 kg



Optional Hepa filter € 465,00

Supervak 77

GRINDING
SINGLE DISC
TOOLS
SPECIAL
VACUUM
CHEMICALS
MARKETING

HEPA Filter included



▶ SUPERVAK 77: are the ideal vacuum cleaner to connect to medium sized grinders. They are Ideal for all works in which big quantity of fine dust have to be vacuumed. Thanks to patented Self Cleaning System they can work continuously without having to stop to dismantle and clean the filters.

Main features:

- SC "(Self Cleaning Filter)".
- Longopac system.
- Three powerful independent and detachable motors which can be used as small powerful vacuum cleaners. One of them can be used as a little air blower (optional).
- Secondary filter to protect the motor in case of accidental passage of dust through the main filters.
- Available with cartridge filters (standard) or polyester filter.
- Anti tipping frame.
- Big wheels for easy transport.

* Self-Cleaning System is activated simply by pressing a lever.

TECHNICAL DATA

Model	Motor	Depress. max mm H ₂ O	Volt	Hertz	Filter surface cm ²	Air flow max m ³ /h	Tank capacity	Dimensions WxHxD cm	Weight	Price
SUPERVAK 77SV Tristadio	3x1600 W	2450	220	50/60	42000	600	bag	114x157x78	90 Kg	€ 4.950,00



Self cleaning system



3 Big self cleaning filters

DATA FOR SHIPPING		
Vol. Packaging	Size Packaging	Weight
77 1,65 m ³	120x80x172 cm	128 Kg



Hopper opening from outside

Supervak X3

Dust collector with built-in cyclonic pre separator and "automatic air pulse" self cleaning system.



- Supervak X3 is equipped with:
 - Automatic ASC "Air pulse cleaning system" thanks to air blasts regulated by an electronic timer keep filters always clean.
 - Pre-separator cyclon integrated in the drum, hold over 90% of dust collecting them into plastic bag.
 - Shockproof drum with futuristic design 100% Made in Italy.
 - Powerful motors equipped with Hepa filter.
 - High reduction for an easy transport.

TECHNICAL DATA

Model	Motor	Depress. max mm H ₂ O	Volt	Hertz	Filter surface cm ²	Air flow max m ³ /h	Tank capacity	Dimensions WxHxD cm	Weight	Price
SUPERVAK X3	3x1600 W	2450	220	50/60	14000	600	bag	125x65x165 Working position 125x65x130 Storage position	125 Kg	€ 5.595,00



Height reduction for transport

DATA FOR SHIPPING		
Vol. Packaging	Size Packaging	Weight
1,34 m ³	80x120x140 cm	125 Kg



Hepa filters standard

Supervak 66-67

GRINDING

SINGLE DISC

TOOLS

SPECIAL

VACUUM

CHEMICALS

MARKETING

Supervak 66



Supervak 67



Dust extractors with "Air-Pulse" cleaning system

HEPA Filter included

▶ SUPERVAK 67-66: Industrial vacuum cleaner with "AIR pulse cleaning system" for filters that ensures a long running time. Ideal to vacuum huge quantities of dust even fine. Suggested to be connected to sanding machines, grinders, core drills, drilling and for medium sized grinding machines.

Main Features:

- Taller tank with cyclone system to facilitate the settling of the dust.
- Polyester Stellar filter with "Air Pulse System".
- Model 66 equipped with 2 powerful single-phase motors two-stages 1400-watt each.
- Model 67 equipped with 3 powerful single-phase motors two-stages 1400-watt each.
- Robust trolley with big wheels for easy transport on unlevelled floors.
- Hopper with easy opening for the discharge of the dust.
- 5 meters tuboflex.
- Basket for Accessories.
- Hepa filter included.
- Longopac system.

TECHNICAL DATA

Model	Motor	Depress. max mm H ₂ O	Volt	Hertz	Filter surface cm ²	Air flow max m ³ /h	Noise level dB/(A)	Tank capacity	Dimensions WxHxD cm	Weight	Price
SUPERVAK 66	2x1400 W	2400	110/220	50/60	12000	430	75	bag	72x142x48	45 Kg	€ 2.295,00
SUPERVAK 67	3x1400 W	2400	110/220	50/60	12000	640	75	bag	72x142x48	40 Kg	€ 2.395,00



Air Pulse Cleaning



Stellar filter

DATA FOR SHIPPING		
Vol. Packaging	Size Packaging	Weight
1,23 m ³	60x75x165 cm	55 kg



Hepa filter included

Supervak 60

Dust extractor with "Automatic Air Pulse cleaning system"



▶ SUPERVAK 60: Industrial vacuum cleaner with "Air Pulse Cleaning System" for filters that ensures a long running time. Ideal to vacuum huge quantities of dust even fine. Suggested to be connected to sanding machines, grinders, core drills, drilling and for medium sized grinding machines.

Main details:

- New powerful motor with 1400 watt max and longer carbon brush.
- Air pulse system to clean the main filter.
- Plastic Bag system to collect the dust.
- HEPA 10 filter standard.
- Tangential inlet and cyclone system to create the effect cyclone dust.
- Special trolley for the best working position.
- Compact system for easy transport.

TECHNICAL DATA

Model	Motor	Depress. max mm H ₂ O	Volt	Hertz	Filter surface cm ²	Air flow max m ³ /h	Noise level dB(A)	Tank capacity	Dimensions WxHxD cm	Weight	Price
SUPERVAK 60	1400 W	3253	220	50/60	9000	144	75	bag	39x110x54	23 kg	€ 1.595,00



Height reduction for transport



Perfect to move during the work

DATA FOR SHIPPING

Vol. Packaging	Size Packaging	Weight
1,23 m ³	60x75x165 cm	33 kg



Air Pulse System to Clean filters

Supervak K11

GRINDING
SINGLE DISC
TOOLS
SPECIAL
VACUUM
CHEMICALS
MARKETING

Vacuum cleaner with cyclonic pre-separator.



Supervak K11: Professional and efficient vacuum cleaner equipped with two stainless steel drums and cyclonic pre-separator. The small size of this vacuum cleaner is the ideal solution for transportation in small vehicles and for operations in tight areas always ensuring performances at the top. It is suitable also for the vacuuming of fine cement dusts, sawdust, scraps and dust in general. Can be connected to sanders, grinders, sanders.

TECHNICAL DATA

Model	Power motor	Motor	Volt	Hertz	Filter surface cm ²	Air flow max m ³ /h	Depress. max mm H ₂ O	Tank capacity	Weight	Price
SUPERVAK K11	1400 W	1 By-pass	220	50/60	3740	215	2380	23 lt	26 kg	€ 1.235,00



Cyclonic pre-separator.



Perfect to move during the work



Hepa filter

Supervak Smart 15H



Supervak Smart 15H: Thanks to the insertion of a “spacer ring” it delivers increased dust collecting capacity. The Supervak Smart 15H, with the addition of a KIT BAG (optional) can use “common plastic bags”. When it is not required to vacuum large amounts of dust the “spacer ring” can be removed to reduce the dimensions.

- Powerful but easy to carry even on the stairs because it can be easily disassembled into two part.
- Thanks to the SC “self cleaning filter” system, large volumes of dust can be vacuumed unto the filling of the drum without having to constantly clean the filter by hand as in normal vacuum cleaner.
- Also usable as a small “air- blower” (optional).
- Secondary filter to protect the motor in case of an accidental passage of dust through the primary filter.
- Hepa filter on request.

* The Self-Cleaning System is activated exchanging the positions of the suction pipe.

TECHNICAL DATA

Model	Motor	Depress. max mm H ₂ O	Volt	Hertz	Filter Surface	Air flow max m ³ /h	Tank capacity	Dimensions WxHxD cm	Weight	Price
SUPERVAK SMART 15HN	1400 W	2350	110/220	50/60	Hepa	200	45 l	59x80x39	30 kg	€ 995,00



Hepa filter optional



DATA FOR SHIPPING		
Vol. Packaging	Size Packaging	Weight
0,30 m ³	60x80x62cm	40 kg



Professional use

Pre-separators

**New series of pre-separators
the best to vacuum huge quantities
of dust even from long distance.**



▶ Pre-Separators to vacuum huge quantity of dust from the long distance. All the dust is collected into the pre-separator while only the minimum fine dust reach the vacuum. It is possible to vacuum directly into the pre-separator even from long distance 40-50 meters. The preseparator increases highly the productivity of the vacuum cleaner and the quality of its performances. It collects and separates large particles, larger chips, pieces of metal, screws, pieces of glass and other things that can occur on a construction site, before reaching the vacuum cleaners. This system increases the dust extractor's overall capacity and extends the life of the filters.

GRINDING
SINGLE DISC
TOOLS
SPECIAL
VACUUM
CHEMICALS
MARKETING



PRE-SEPARATOR 400 STEEL
Pre-separator with stainless steel tank of 90 lt.
Pre-separator 400 steel € 485,00



PRE-SEPARATOR 400B STEEL
Pre-separator with swinging stainless steel tank of 114 Lt.
Pre-separator 400B steel € 535,00



PRE-SEPARATOR 400 COMPACT
Pre-separator with plasti tank of 90 Lt., ideal for vacuuming liquid and acid materials.
Pre-separator 400 Compact € 550,00



PRE-SEPARATOR CYCLON 76
This series has been designed for heavy duty application like connecting to floor grinding machines. These special pre-separators are equipped with:
• Special "cyclon system" that collects about 95 % of the dust.
• LONGOPAC system to collects easily the dust in the plastic bag.
• Robust trolley for easy transport even in construction areas.
Pre-separator Cyclon 76 € 1.795,00



ACCESSORIES FOR SUPERVAK

GRINDING



ACCESSORIES ø50mm - SUPERVAK 80/90/100/200/250/300 inlet ø70mm

07434K5	Flexible hose ø70/50 mm - 5 mt	€ 118,00
07434K10	Flexible hose ø70/50 mm - 10 mt	€ 168,00
07243K5	Flexible hose Anti abrasion-antistatic ø70/50 mm - 5 mt	€ 178,00
07243K10	Flexible hose Anti abrasion-antistatic ø70/50 mm - 10 mt	€ 295,00
R7243	Double elbow chromate steel	€ 87,00
R7865	Suction brush for dust	€ 107,00
R7246	Suction brush for wet and dry	€ 97,00
06866	60 cm Flat lance Chromate Steel	€ 29,50
07067	Elbow shaped flat lance chromate steel	€ 29,50
07177	30 cm Flat lance Chromate Steel	€ 21,50
R7240	Inox bristle brush	€ 78,50
R7259	Complete rubber Brush	€ 28,50
R7260	Complete flat lance - Rubber	€ 25,50
2367K	connection tuboflex ø50 mm	€ 18,00

SINGLE DISC

TOOLS



ACCESSORIES ø40mm - SUPERVAK 80/90/100/200/250/300 inlet ø70mm

07428/70K5	Flexible ø60/40 - 5 mt.	€ 108,00
R0580	Double elbow Chromate steel	€ 26,50
R7241	Horsehair bristle brush	€ 64,50
06404	85 cm Stainless steel tube	€ 39,50
2773	Connection 60/40	€ 6,50
2774	Connection 60/40	€ 6,50
3892K	Floor brush (for 0580)	€ 19,50
3893K	Squeegee brush (for 0580)	€ 20,50
0003K	flat lance	€ 3,70
6295K	Brush	€ 4,50

SPECIAL



ACCESSORIES ø40mm - SUPERVAK 40/70/75/76/77/623/SMART

R1325	Accessories kit 38-40mm standard.	€ 99,50
3892	Floor brush (for 0580)	€ 19,50
3893	Squeegee brush (for 0580).	€ 20,50
3894	Carpet brush (for 0580).	€ 26,50
R0580	Steel double elbow	€ 26,50
2333K	Rubber lath (for 6385,3893).	€ 4,40
2327K	Lath with front strip (for 6385,6393)	€ 6,90
3895	Lath with back strip (for 6385,6393)	€ 3,60
0008XK	Tuboflex 3mt ø38	€ 26,50
0003	Flat lance	€ 3,70
6295	Round Brush	€ 4,50
0001K	Extension tube mt 0,5	€ 5,10

VACUUM

CHEMICALS

MARKETING



TUBOFLEX

00520K3	Flexible hose ø50/50 cpl mt3	€ 46,00
00520K5	Flexible hose ø50/50 cpl mt5	€ 69,00
00520K10	Flexible hose ø50/50 cpl mt10	€ 125,00
07410K5	Tuboflex Anti abrasion-antistatic cpl ø50/50 mt5	€ 178,00
07410K10	Tuboflex Anti abrasion-antistatic cpl ø50/50 mt10	€ 295,00
07797S5	Superflex hose Anti abrasion-antistatic cpl ø50/50 mt5	€ 255,00
07797S10	Superflex hose Anti abrasion-antistatic cpl ø50/50 mt10	€ 445,00
00082K	Tuboflex standard ø38 per meter	€ 6,90
07261K	Tuboflex Anti abrasion-antistatic ø38 per meter	€ 17,50
00624K	Tuboflex standard ø32 per meter	€ 4,95



REMOTE CONTROL FOR SUPERVAK 200RX - 250RX - 300RX

Drum

GRINDING
SINGLE DISC
TOOLS
SPECIAL
VACUUM
CHEMICALS
MARKETING

Drum 200 l Tipping



“DRUM SYSTEM” is the best way to collect large quantities of water and mud especially those created during floor grinding procedures. When the drum is full the “Kit-Drum” could be connected to an other drum.

*The CPL version includes: Drum, Trolley, Head motor, Tuboflex 2.5m, Double elbow and Vacuum brush for liquids.

*The KIT version includes: Head motor, cover with hole for head connecting, Tuboflex 2.5m, Double elbow and Vacuum brush for liquids.

TECHNICAL DATA

Model	N. Motor	Power	Volt	Depress. max mm H ₂ O	Air flow max m ³ /h	Noise level dB/(A)	Tank	Dimensions WxHxD cm	Weight	Price
DRUM 629 CPL	2 By-pass	2800 W max	1-phase	2180	430	74	200 l	89x160x94	110 kg	€ 2.565,00
DRUM 640 CPL	3 By-pass	3500 W max	1-phase	2180	640	74	200 l	89x160x94	110 kg	€ 2.665,00
KIT DRUM 629	2 By-pass	2800 W max	1-phase	2180	430	74	--	n.a.	n.a.	€ 895,00
KIT DRUM 640	3 By-pass	3500 W max	1-phase	2180	640	74	--	n.a.	n.a.	€ 995,00
TROLLEY only	--	--	--	--	--	--	--	n.a.	n.a.	€ 1.570,00
DRUM only	--	--	--	--	--	--	200 l	n.a.	n.a.	€ 195,00



Trolley Tipping



Quick hitch and secure

DATA FOR SHIPPING		
Vol. Packaging	Size Packaging	Weight
1,60 m ³	80x120x100 cm 110x110x50 cm	kg 120



Tap Optional

Junior Inox



GRINDING

SINGLE DISC

TOOLS

SPECIAL

VACUUM

CHEMICALS

MARKETING

The JUNIOR INOX series has been designed with the most advanced technology and build with:

- Independent self cooling motors.
- Stainless steel tank.
- Anti foam system.
- Anticollision trolley.
- Strong grip handle.
- Strong directionable wheels.

* The prices include the standard accessories.

TECHNICAL DATA

Model	N. Motor	Power	Volt	Depress. max mm H ₂ O	Air flow max m ³ /h	Tank	Dimensions WxHxD cm	Price
JUNIOR INOX101 WET-DRY	1 By-pass	1200 W max	1-phase	2380 mm	170 m ³ /h	23 l	39x54x39	€ 249,00
JUNIOR INOX 303	1 By-pass	1400 W max	1-phase	2380 mm	215 m ³ /h	23 l	39x66x39	€ 330,00
JUNIOR INOX 503	1 By-pass	1400 W max	1-phase	2380 mm	215 m ³ /h	37 l	52x87x52	€ 373,00
JUNIOR INOX 423	2 By-pass	2600 W max	1-phase	2380 mm	430 m ³ /h	62 l	52x87x52	€ 549,00
JUNIOR INOX 423 M	2 By-pass	2600 W max	1-phase	2380 mm	430 m ³ /h	62 l	56x91x53	€ 631,00
JUNIOR INOX 423 B	2 By-pass	2600 W max	1-phase	2380 mm	430 m ³ /h	77 l	58x107x68	€ 698,00
JUNIOR INOX 433	3 By-pass	3600 W max	1-phase	2380 mm	645 m ³ /h	62 l	52x87x52	€ 698,00
JUNIOR INOX 433 M	3 By-pass	3600 W max	1-phase	2380 mm	645 m ³ /h	62 l	56x91x53	€ 738,00
JUNIOR INOX 433 B	3 By-pass	3600 W max	1-phase	2380 mm	645 m ³ /h	77 l	58x107x68	€ 798,00

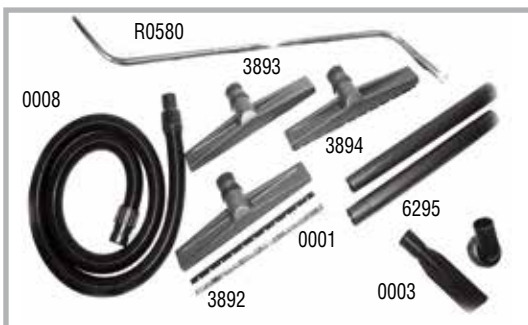

Standard for 300-400-500-600-800-900



Standard for IO1



Version B: Tipping

Junior Compact

GRINDING
SINGLE DISC
TOOLS
SPECIAL
VACUUM
CHEMICALS
MARKETING

423B
433B

423M
433M

303



The JUNIOR COMPACT series are made with the most advanced technology. They are the best vacuum cleaners in the market. • Independent self cooling motors. • Crack proof tank. • Anti foam system. • Anticollision trolley. • Strong grip handle. • Directionable wheels. • The M version has in the back a special pipe device to discharge the water collected. • The B version has a tipping tank.

*The prices include the standard accessories.

TECHNICAL DATA

Model	N. Motor	Power	Volt	Depress. max mm H ₂ O	Air flow max m ³ /h	Tank	Dimensions WxHxD cm	Price
COMPACT 303	1 by pass	1400 W max	1-phase	2380 mm	215 m ³ /h	37 l	38x70x38	€ 366,00
COMPACT 423 M	2 by pass	2600 W max	1-phase	2380 mm	430 m ³ /h	90 l	57x90x57	€ 680,00
COMPACT 423 B	2 by pass	2600 W max	1-phase	2380 mm	430 m ³ /h	114 l	57x108x60	€ 810,00
COMPACT 433 M	3 by pass	3600 W max	1-phase	2380 mm	640 m ³ /h	90 l	57x90x57	€ 778,00
COMPACT 433 B	3 by pass	3600 W max	1-phase	2380 mm	640 m ³ /h	114 l	57x108x60	€ 908,00



Standard accessories



Tipping



Market

Junior Telecontrol

415 - 429

315



TELECONTROL: These models come with built in electrical socket to connect power tools. On request it is available the version to connect air power tools. Stainless steel tank.

TECHNICAL DATA

Model	N. Motor	Power	Volt	Depress. max mm H ₂ O	Air flow max m ³ /h	Tank	Dimensions WxHxD cm	Price
JUNIOR 315 TELECONTROL	1 By-pass	1200 W max	1-phase	2200 mm	170 m ³ /h	23 l	39x66x39	€ 375,00
JUNIOR 429 TELECONTROL	2 By-pass	2400 W max	1-phase	2400 mm	340 m ³ /h	62 l	52x87x52	€ 587,00



2737



1679

Accessories ø 36

Falcon, Scup & Hot Flash

GRINDING

SINGLE DISC

TOOLS

SPECIAL

VACUUM

CHEMICALS

MARKETING



Injection - Extraction washer machine

Scup

Hot Flash is the evolution of cold water extractor. Thanks to a boiler fixed inside the head, it produces hot water guaranteeing a better quality of cleaning.
 Falcon are multipurpose equipments which, thank to their injection-extraction system, help you to clean and wash all kind of surface such as: carpet, curtains, sofas, pavements, walls, wallpaper etc. The two powerful motors allow to dry the surface in faster time. Ideal for car-wash and for cleaning contractors. All these machines can be used as a normal vacuum cleaner.
 *Falcon Series includes art.2551 Tuboflex, art.03240 Filter Kit and art.R0752 Nozzle for couch.

TECHNICAL DATA

Model	N. Motor	Power max	Volt	Depress. max mm H ₂ O	Air flow max m ³ /h	Power Boiler W	Flow Pump	Pump W	Pump pressure bar	Tank Detergent	Tank	Price
SCUP	1	1200 W	230	2200 mm	170 m ³ /h	--	--	80	2	11 lt	32 lt	€ 658,00
FALCON 650	2	2400 W	220	2200 mm	340 m ³ /h	--	--	48	2	25 lt	62 lt	€ 925,00
FALCON 700	2	2400 W	200	2200 mm	340 m ³ /h	--	--	90	2	25 lt	62 lt	€ 1.095,00
HOT FLASH	2	2400 W	220	2200 mm	340 m ³ /h	950 W	0,8 l/min	--	2	25 l	62 l	€ 1.678,00



Optional accessories Falcon & Hot Flash



Standard accessories ø 38 Falcon & Hot Flash

Vapor Max & Vapor Little 300

No Stop Steam



Special Covering for fast drying of car seat with hot air.



NEW STEAM CLEANERS

The new line of professional steam cleaners, with vacuum system, to make cleaning and sanification easier and quicker saving time and money.

Vapor Little the most practical and efficient steam cleaner. It is especially designed for restaurants, canteens, butcher's shop, kitchens and for everywhere HACCP regulations have to be fulfilled. Thanks to its full range of exclusive accessories it is possible to clean and to disinfect kitchen tools, windows, bathrooms,walls,carpets and anything needs perfect cleaning. It is equipped with separate tank, for water reloading, not under pressure, which automatically feeds the boiler guaranteeing no stop steam.

Vapor Max the most powerful steam cleaner. It is especially designed for big restaurants, canteens, big butcher's shop, food factories, hospital and for everywhere it needs to apply regulation of HAC. Thanks to its full range of exclusive accessories it is possible to clean and to disinfect kitchen tools, windows, bathrooms,walls,carpets and anything needs perfect cleaning. It is equipped with separate tank, for water reloading, not under pressure, which automatically feeds the boiler guaranteeing an unlimited autonomy.

TECHNICAL DATA

Model	Volt	Power max	Power Boiler	Power Vacuum	Boiler capacity	Hot air power	Working pressure	Temperature boiler	Water Tank	Waste Tank capacity	Dimensions WxHxD cm	Weight	Price
VAPOR LITTLE 300	230	2900 W	1700 W	1200 W	2 l	--	4 bar	140 °c	36 l	6 l	--	--	€ 1.365,00
VAPOR MAX	220-240	--	1800 W	1400 W	2,8 l	1400 W	4 bar	140 °c	36 l	6 l	57x46x100	41 kg	€ 3.950,00



Standard accessories



Standard accessories



GRINDING

SINGLE DISC

TOOLS

SPECIAL

VACUUM

CHEMICALS









MARKETING

Polish Powder

The most popular polishing powders!



POLISH POWDER

PICTURE	CODE	NAME	SIZE	€ each
	POLISH KP85 An excellent powder for polishing marble and terrazzo after grinding but it can also be used for daily maintenance of polished marble, terrazzo, porcelain and glass surfaces. KP85 is a mix of fine abrasive powders to be mixed with water to quickly remove caked-on soil, soap scum, and embedded stains from grout virtually immediately. It is the ideal product to be used in commercial areas, kitchens, restaurants, shopping malls, etc. On either polished, honed and flamed or other rough-textured stone surfaces.			
	000663	KP 85	kg 5	€ 69,00
	000662	KP 85	kg 20	€ 215,00
	POLISH KMT For soft marbles like Carrara, limestone etc.			
	000647	KMT	kg 5	€ 86,00
	POLISH GREY For palladina, terrazzo and marbles not easy to polish.			
	000661	Grey	kg 5	€ 174,00
	POLISH KP 92 For standard marbles and limestone.			
	000650Box	KP 92	Box 6x1 kg	€ 129,00
	00650	KP 92	kg 5	€ 82,00
	POLISH COLOR For green marble and marble containing iron.			
	000649	Color	kg 5	€ 146,50
	POLISH TERRAZZO For terrazzo, mosaic and palladiana.			
	000648	Terrazzo	kg 5	€ 155,00
	POLISH KG For granite.			
	000659	KG Clear	kg 5	€ 195,00
	000657	KG	kg 5	€ 195,00
	POLISH GRES To polish porcelain tiles after proper honing.			
	000666	KG Gres	kg 5	€ 165,00
	POLISH KP92 CREAM Ready and easy to use polishing cream for marble. It doesn't smell!			
	00656kg5	KP92 Cream	kg 5	€ 73,50
	00656PZ	KP92 Cream	kg 1,5	€ 25,50
	00656Box	KP92 Cream	Box 6x1 kg	€ 147,00

GRINDING

SINGLE DISC

TOOLS







SPECIAL

VACUUM

CHEMICALS

MARKETING

SPECIAL PRODUCTS

PICTURE	CODE	NAME	SIZE	TYPE	€ each
	SMAKKIO				
	04832	Smakkio Oil	1 l	It removes oil spots.	€ 22,00
	04830	Smakkio Wine & Coffee	1 l	It removes wine and coffee spots.	€ 22,00
	04831	Smakkio Urine	1 l	It removes spots left by urine, leaves, wood etc.	€ 22,00
	04834	Smakkio Mold	1 l	It removes spots due to mold, lichen and weed.	€ 22,00
	04837	Smakkio Rust	1 l	To remove rust.	€ 17,50
	KI WATERPROOFING				
	Water repellent waterproofing agent/sealer for both indoor and outdoor applications.				
	00646Box	KI-Waterproofing	12 x 1 Lt	Solvent Based	€ 295,00
	00646	KI-Waterproofing	1 Lt	Solvent Based	€ 26,50
	KORREKTOR				
	An effective stone colour enhancer ideal for darker-coloured stones such as marble, granite, sandstone, etc.				
	01122BLUWB	Korrektor	1 l	Blue	€ 46,50
	01122NWB	Korrektor	1 l	Black	€ 46,50
	01122VWB	Korrektor	1 l	Green	€ 46,50
	01122RWB	Korrektor	1 l	Red	€ 46,50
	RITOCOCCO				
	Self-polishing varnish. Ideal for polishing hard-to-reach where it is not easy to polish by machine.				
	00645	Ritocco	1 Lt		€ 19,50
	00645Box	Ritocco	12 x 1 Lt		€ 228,00
	BRILL&MORE				
	It also water-proofs the surface of the stone. Ideal for routine maintenance.				
	01126SB	Brill&More	1 Lt	Solvent Based	€ 23,90
	01126SBBox	Brill&More	12 x 1 Lt	Solvent Based	€ 245,00
	01126WB	Brill&More	1 Lt	Water Based	€ 19,50
	01126WBBox	Brill&More	12 x 1 Lt	Water Based	€ 224,00
	ANTIKO 60				
	Water and oil-repellant for indoor use to produce a satin finish antique look.				
	00619	Antiko 60	1 Lt	Solvent Based	€ 19,50
	00619Box	Antiko 60	12 x 1 Lt	Solvent Based	€ 210,00
	SPLENDUR CREAM				
	Water-based wax to polish marble and other stones. It polishes while water-proofing the treated surface.				
	00644SB	Splendur Cream	0,75 kg	Solvent Based	€ 19,50
	00644SBBox	Splendur Cream	12 x 0,75 kg	Solvent Based	€ 212,00
	00644WB	Splendur Cream	0,75 kg	Water Based	€ 19,50
	00644SBBox	Splendur Cream	12 x 0,75 kg	Water Based	€ 212,00

GRINDING

SINGLE DISC

TOOLS

SPECIAL

VACUUM

CHEMICALS

MARKETING



**The best products for
your floors!**

SPECIAL PRODUCT FOR PVC, LINOLEUM, RUBBER, CORK



Follow these recommendations: • 1) Make sure to remove any dirt, coatings, wax or other floor finishes by using our Blitz wax stripper. • 2) If there are no coatings or waxes, the floor can be thoroughly cleaned using our heavy-duty floor cleaner strong. • 3) Rinse thoroughly with clean water and dry the floor using a wet vacuum cleaner. • 4) Apply two coats of Metalwax. For cork floors we recommend a third coat. 5) For daily cleaning, use our PH neutral floor cleaner Emmerol, so as not to damage the floor.

PICTURE	CODE	NAME	SIZE	€ each
	STRONG Heavy-duty cleaner for floors.			
	04104	Strong	Box 4x5Lt	€ 118,00
	BLITZ Wax stripper. Very good to degrease floors.			
	04108	Blitz	Box 4x5Lt	€ 118,00
	METALWAX Self-polishing metallic wax for floor finishing.			
	04110	Metalwax	Box 4x5Lt	€ 216,00
	EMMEROL PH neutral floor detergent for daily maintenance. Ideal for polished floors!			
	04102	Emmerol	Box 4x5Lt	€ 106,00
	EMME 2000 To be used with a regular or high-speed rotary cleaning machine and a red nylon pad.			
	04836	Emme 2000	Box 12x0,75Lt	€ 90,00

GRINDING

SINGLE DISC

TOOLS

SPECIAL

VACUUM

CHEMICALS

MARKETING

SEAL PRODUCTS FOR TERRACOTTA FLOORS



There is a special feeling of warmth in a terracotta floor, but it needs special care! We recommend the following procedure: •1) Wash thoroughly with DK 100 floor cleaner using WINNEX brushes with the Planetary A5. •2) Apply one coat of KI WATERPROOFING to protect the floor from sodium nitrate (saltpeter) formation. •3) Protect it with two coats of METALWAX. •4) For routine maintenance clean with a pH neutral detergent like EMMEROL. When an additional finish is needed, apply KLINLUX.

PICTURE	CODE	NAME	SIZE	€ each
	DK100 It cleans and eliminates sodium nitrate build-up.			
	04105	DK100	Box 4x5Lt	€ 92,00
	KLINLUX Polishing wax carnauba based.			
	04120	Klinlux	Box 4x5Lt	€ 132,00
	METALWAX Self-polishing metallic wax for floor finishing.			
	04110	Metalwax	Box 4x5Lt	€ 216,00
	EMMEROL PH neutral floor detergent for daily maintenance. Ideal for polished floors!			
	04102	Emmerol	Box 4x5Lt	€ 106,00
	ANTIKO 60 Water and oil-repellant for indoor use to produce a satin finish antique look.			
	00619	Antiko 60	1 Lt	Solvent Based € 19,50
	00619Box	Antiko 60	12 x 1 l	Solvent Based € 210,00
	KI WATERPROOFING Water and oil-repellant for indoor use to produce a satin finish antique look.			
	00646SB	KI-Waterproofing	1 l	Solvent Based € 26,50
	00646SBox	KI-Waterproofing	12 x 1 l	Solvent Based € 295,00

GRINDING

SINGLE DISC

TOOLS

SPECIAL

VACUUM

CHEMICALS

MARKETING

THE BEST MASTIC



Klindex offers a full range of stucco for filling and gluing all types of marble and granite. Available in: solid, semisolid, liquid, transparent, straw, White and coloured.

PICTURE	CODE	NAME	SIZE	TYPE	€ each
---------	------	------	------	------	--------



FULL STUKKO TIXO

A polyester stucco for marble and granite for general repairing, bonding and for vertical application.

01112PBox	Tixo	12 x 1 kg	Straw	€ 108,00
01112BBox	Tixo	12 x 1 kg	White	€ 108,00
01112NBox	Tixo	12 x 1 kg	Black	€ 108,00
01112VBox	Tixo	12 x 1 kg	Green	€ 108,00
01112RBox	Tixo	12 x 1 kg	Red	€ 108,00



FULL STUKKO LIQUID Flowing polyester stucco for general repairing and bonding of horizontal pieces. Also suitable for filling cracks and holes. Very good to use on travertine and terrazzo floors.

01117PBox	Liquid	12 x 1 kg	Straw	€ 108,00
01117BBox	Liquid	12 x 1 kg	White	€ 108,00
01117NBox	Liquid	12 x 1 kg	Black	€ 108,00
01117VBox	Liquid	12 x 1 kg	Green	€ 108,00
01117RBox	Liquid	12 x 1 kg	Red	€ 108,00



FULL STUKKO TIXO GOLD TRANSPARENT

Colourless and very transparent polyester stucco. Ideal for consolidating stone or repairing fine cracks or fractures. Faster curing time and more suitable for wide cracks. Easily coloured to match any stone using Mix-Colour. Excellent for travertine.

01114SBox	Transparent Gold	12 x 1 kg	Tixo / Cream	€ 214,00
01114LBox	Transparent Gold	12 x 1 kg	Liquid	€ 204,00



FULL EPOX

Epoxy resin with hardener (4:2), ideal for consolidating stone or REPAIRING fine cracks or fractures. Faster curing time and more suitable for wide cracks. EASILY coloured to match any stone using Mix-Colour.

01138	Full Epox	1 kg	Solido / Solid	€ 26,50
01139	Hardener			€ 22,50



MIX-COLOUR (5 pcs)

Product for polyester and acrylic mastic. Available in many colours.

01115	Mix Color	5 pcs		€ 44,00
-------	-----------	-------	--	---------

GRINDING

SINGLE DISC

TOOLS

SPECIAL

VACUUM

CHEMICALS

MARKETING

PICTURE	CODE	NAME	SIZE	TYPE	€ each
---------	------	------	------	------	--------

STUCCO STICK

Stucco stick Box 4 Pcs (available in various colours. Ideal for small repairs on polished floors.)



00631MIX	Stucco Stick	3 kg	Mix Color	€ 59,70
00631BEIGE	Stucco Stick	1 kg / 4 Stick	Beige	€ 19,90
00631BIANCO	Stucco Stick	1 kg / 4 Stick	White	€ 19,90
00631GIALLO	Stucco Stick	1 kg / 4 Stick	Yellow	€ 19,90
00631GRIGIOCH	Stucco Stick	1 kg / 4 Stick	Grey	€ 19,90
00631NERO	Stucco Stick	1 kg / 4 Stick	Black	€ 19,90
00631NOCCIOLA	Stucco Stick	1 kg / 4 Stick	Hazel	€ 19,90
00631PAGLIERINO	Stucco Stick	1 kg / 4 Stick	Straw	€ 19,90
00631ROSACH	Stucco Stick	1 kg / 4 Stick	Pink	€ 19,90
00631ROSSO	Stucco Stick	1 kg / 4 Stick	Red	€ 19,90
00631VERDE	Stucco Stick	1 kg / 4 Stick	Green	€ 19,90

ELECTRIC MASTIC-HEATER



00642	Electric Mastic-Heater		110 Volt	€ 142,00
00632	Electric Mastic-Heater		220 Volt	€ 142,00

SCRUBBER TO REMOVE EXCESS STUCCO



05153	Scrubber complete			€ 18,50
05157	Blade spare part	10 pcs		€ 9,50



GRINDING

SINGLE DISC

TOOLS

SPECIAL

VACUUM

CHEMICALS

MARKETING

SPARE PARTS

PICTURE	CODE	NAME	MACHINE	€ each
	PLASTIC HANDLE R-L			
	CM01301	Handle Covering (2pcs)		€ 45,00
	CM00301	Level to adjust Handle		€ 20,70
	CM00403	Left Starting Level		€ 20,70
	CM00503	Right Starting Level		€ 20,70
	CM00702	Aluminium hose for Handle gear		€ 87,00
	PLS004	Switch ON/OFF		€ 45,00
	CAPACITOR 220V 50Hz			
	CEG056	Starting capacitor	Unika, Rocky	€ 42,00
	CEG013	Working capacitor	Unika, Kroma 2,5hp, Rocky	€ 42,00
	CEG002	Starting capacitor	Kroma, Levighetor, Timba	€ 51,00
	CEG003	Working capacitor	Kroma, Levighetor, Timba	€ 42,00
	MOT023	Centrifugal switch	Unika, Kroma, Lev., Timba	€ 68,00
	CONNECTION CLUTCH			
	RD10301	Connection Clutch	Unika,	€ 51,00
	RD04101	Connection Clutch	LEV.200rpm	€ 57,00
	SATELLITE			
	RD21901	Pinion	Unika,	€ 51,00
	RD21801	Helicoidal Satellite	Unika,	€ 50,00
	RD22901	Pinion	Lev.155rpm, Timba	€ 47,50
	RD31002	Plastic Satellite	Kroma	€ 53,50
	RD24001	Pinion	Lev.200rpm	€ 80,00
	RD26201	Metallic Satellite	Lev.200rpm	€ 61,00
	RD26401	Plastic Satellite	Lev.155rpm, Timba	€ 32,50
	RD23001	Metallic Satellite	Lev.155rpm, Timba	€ 70,50
		SPLASH GUARD FOR GRINDING MACHINES		
AP4501		Splash Guard 155x11,5cm	K800, K1000, K2000, K3, K4	€ 68,00
AP4501H		Splash Guard 155x15cm	K800, K1000, K2000 with brushes	€ 68,00
AP12601		Splash Guard 166x11,5cm	K1200	€ 68,00
AP12601H		Splash Guard 166x155cm	K1200 with brushes	€ 68,00
AP8403		Splash Guard 184x11,5cm	K1500, Rotoklin 400	€ 68,00
AP8401H		Splash Guard 184x15cm	K800, K1000, K2000 with Spring Holder System	€ 63,50
AP4602		Splash Guard 215x15cm	Levighetor Max	€ 72,50
	VACUUM GUARD FOR GRINDING MACHINES			
	AP1501	Vacuum Guard 156x11,5cm	K800W, K1000, K2000	€ 68,00
	AP9701	Vacuum Guard 156x15cm	K1200	€ 68,00
	AP9501	Vacuum Guard 175x11,5cm	K1500	€ 68,00
	AP9501H	Vacuum Guard 175x15cm	K1500 with Spring holder	€ 68,00
	AP018103	Vacuum Guard Kit	Expander 650	€ 256,00
	AP018203	Vacuum Guard Kit	Expander 750	€ 285,00
	AP30803	Vacuum Guard without pipe union	Expander 750	€ 185,00
	AP018002	Vacuum Guard Kit	Expander 850	€ 298,00
	AP30403	Vacuum Guard without pipe union	Expander 850	€ n.a.
	AP018303	Vacuum Guard Kit	Expander 950	€ 345,00
	AP31502	Vacuum Guard without pipe union	Expander 950	€ 278,00
	AP021801	Counterguard with pipe union	Expander 950-850-750-650	€ 85,00

GRINDING

SINGLE DISC

TOOLS

SPECIAL

VACUUM

CHEMICALS

MARKETING



HANDLE

MAN005	Handle	€ 12,50
--------	--------	---------



ANTISHOCK SYSTEM.

GUA004	Antishock	€ 94,00
--------	-----------	---------



PLASTIC CLUTCH

01010P	Clutch Unika, Futura, Kroma, Levighetor, Timba	€ 12,50
00621	Clutch Rocky, Futura	€ 12,50



ABSORBER PAD HOLDER

Important to use for grinding marble floors and for grinding on very uneven concrete floors.

PL27007	Absorber 240mm	€ 145,00
PD2901	Absorber 340mm	€ 170,00



PLATE with 3 ATTACKS ø100mm-AS

Aluminium Plate to use with Expander and Levighetor Max. It allows you to use metal, reinoid and 100 mm diameter AS Pavelux tools, that is to say the same tools designed for Levighetor 640.

PD2701	Plate 240mm A3-100mm	€ 185,00
PD3001	Plate 340mm A3-100mm	€ 199,00



VELCRO BACKED PAD HOLDER

With quick attachment for resin diamond disc and floor pads 9" (The machine needs 3 pieces).

PD40901	Pad holder 200mm	€ 82,00
PD05805	Pad holder 240mm	€ 82,00
PD42901	Pad holder 340mm	€ 98,00



PAD HOLDER 240MM FOR PAVELUX AND RESINBOND

PD1601	Pad holder 240mm to use pavelux 240mm	€ 88,00
--------	---------------------------------------	---------



PAD HOLDER FOR BRUSHES AND SPIKES

For brushes 240mm and Spikes 200mm (needs 3 pcs for 1 set)

UT43402	Tools holder 240mm	€ 75,00
---------	--------------------	---------



PAD HOLDER for TRAPEZOID TOOLS

Holder to use trapezoid tools or diamond butterfly.

UT43402	Pad holder 200mm	€ 89,00
PL28003	Pad holder 240mm	€ 89,00
PD43001	Pad holder 340mm	€ 98,00



JUMBO PAD HOLDER

AP011102	Pad holder Jumbo 9,5"/ø240mm Kit 3 pcs	€ 590,00
PD3201	Pad holder Jumbo 13"/ø340mm Kit 3 pcs	€ 630,00

GRINDING
SINGLE DISC
TOOLS
SPECIAL
VACUUM
CHEMICALS
MARKETING



Electric Panel for construction job sites, with stand and wheels, cable winder and 25 m. extension tube 5G6 with plug of 32A 5P 400V.

TFG20101/SPRT	Electric Panel	€ 1.009,00
---------------	----------------	------------



- 2 sockets of 16A 1Ph 200V.
- 1 socket of 16A 3Ph 5P 400V.
- 1 socket of 32A 3Ph 5P 400V.
- Fiberglass Box Self-extinguishing V0.
- Protection grade IP 65.
- 2 m H07RN-F cable and plug CEE IP 67.
- Sockets protected by interlocked magnetothermic differential.
- Emergency button always present.
- Earthed screw.
- Thermosetting resin handle for portable use.
- Brackets for fastening to wall.
- Fiberglass cable winder.
- Stand and wheels.



Especially suited for construction job sites and difficult environments.

The Electric Panel features a new LED system that helps you to check the line of your building site. Allows you to immediately identify the location of the fault. The LED system also displays the arrival of the earth, allowing you to work safely.



Electric Panel

TFG20101C	Electric Panel	€ 862,00
-----------	----------------	----------

- 2 sockets of 16A 1Ph 200V.
- 1 socket of 16A 3Ph 5P 400V.
- 1 socket of 32A 3Ph 5P 400V.
- Fiberglass Box Self-extinguishing V0.
- Protection grade IP 65.
- 2 m H07RN-F cable and plug CEE IP 67.
- Sockets protected by interlocked magnetothermic differential.
- Emergency button always present.
- Earthed screw.
- Thermosetting resin handle for portable use.
- Brackets for fastening to wall.

Especially suited for construction job sites and difficult environments.



The Electric Panel features a new LED system that helps you to check the line of your building site. Allows you to immediately identify the location of the fault. The LED system also displays the arrival of the earth, allowing you to work safely.



25 mt. Extension tube 5G6 with plug 32A 5P 400V.

PR38073056	Extension	€ 483,00
------------	-----------	----------



Extension tube Robust 200 - 25 mt. 5G6 3P+N+T with 32A socket - HQ series

CM035701 Extension tube € 699,00



Extension tube Robust 200 - 25 mt. 3G4 2P+T with 16A socket - HQ series

CM036501 Extension tube € 348,00



Extension tube Robust 200 - 25 mt. 5G6 3P+N+T with 16A socket - HQ series

CM036101 Extension tube € 675,00



Extension tube Robust 200 - 25 mt. 5G10 3P+N+T with 63A socket - HQ series

CM035301 Extension tube € 1.200,00



Multiple - 3 exits 3P+N+T with cable 400V/200V

VB1850 Multiple € 119,00



Multiple - 3 exits 1P+N+T with cable 200V

VB1552 Multiple € 57,00

GRINDING

SINGLE DISC

TOOLS

SPECIAL

VACUUM

CHEMICALS

MARKETING

Edward cardboard shredder

Cardboard Shredder Edward Unique in the world with 3 cutting styles: elastic net, chips and strips.

We are pleased to introduce the new range of cardboard shredder series EDWARD: a professional line of industrial, ecological, economic and compact shredders. Enough useless waste and improvised packaging! EDWARD frees space in the warehouse by transforming the cartons into cardboard elastic mesh perfect for packing.

Why buy the Edward cardboard shredder?

- Transforms your used cartons in precious packaging material, without wasting time and effort!
- You can protect your products inside the boxes, without buying polystyrene and bubble wrap.
- Due to its flexibility the cardboard mesh produced is easily adaptable, to any type of packaging with remarkable impact resistance.
- Frees warehouse space needed to store packaging material.
- It cuts the costs of waste disposal and packaging.
- It frees space, ecological and economical.

Technical Advantages:

- Simple and easy to use by means of an on/off switch.
- Sturdy structure and stainless steel crankcase suitable for intensive use in shipping department.
- All models are transportable on wheels.
- Conforms to all norms of national and international safety regulations.
- All models are equipped with a dust suction connection.
- Super-sized engine for optimum reliability.



Net



Strips



Chips

Edward strengths:

- Long lasting steel blades.
- Special gears for hard working cycles.
- Monolithic body structure.
- 12m/minute high cutting speed.
- Bearings for high radial loads.
- Heavy overall machine weight for professional applications.
- Wheels equipped for easy moving.
- Vacuum ready.
- Blades checking window.
- Scratch proof powder coating.
- Anti wear treated.
- Coriander version available , chop the cardboard into small sized corianders.
- Simple and practical to use with two-position switch: on / off.
- Heavy duty body and stainless steel carter suitable for intensive use in freight forwarding departments.
- Complies with all relevant national and international safety standards.
- Over-sized engine for optimum reliability.



GRINDING

SINGLE DISC

TOOLS

SPECIAL

VACUUM

CHEMICALS

MARKETING

Edward cardboard shredder the only one with Hepa dust extractors!



Recycling is better!



Watch the VIDEO

299Series

300Series

400Series

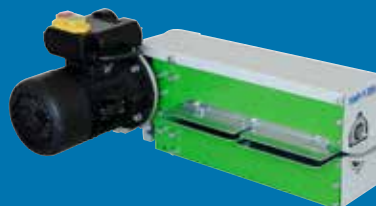

NET series

TECHNICAL DATA

Model	Motor	Volt	Hertz	Cutter feed width	Cutter feed height	Cutting capacity of not pre-processed material	Cutting speed	Continuous run time	Dimensions (with legs kit) WxHxD	Weight	Price
Edward 299R*	1 Hp	220-240	50-60	300mm	10mm	2 m³ per hour	8m/min	8 hours	55x45x28cm (without legs)	38 Kg	€ 2.495,00
Edward 300R*	3 Hp	220-240	50-60	300mm	14mm	4 m³ per hour	14m/min	8 hours	85x105x50cm	120 Kg	€ 3.950,00
Edward 300R*	3Hp	380-400	50-60	300mm	14mm	4 m³ per hour	14m/min	8 hours	85x105x50cm	120 Kg	€ 3.995,00
Edward 400R*	4 Hp	220-240	50-60	400mm	16mm	6 m³ per hour	14m/min	8 hours	90x105x50cm	130 Kg	€ 4.450,00
Edward 400R*	4 Hp	380-400	50-60	400mm	16mm	6 m³ per hour	14m/min	8 hours	90x105x50cm	130 Kg	€ 4.750,00
Edward 500R**	4 Hp	220-240	50-60	500mm	18mm	10 m³ per hour	14m/min	8 hours	130x116x83cm	300 Kg	€ 6.350,00
Edward 500R**	4 Hp	380-400	50-60	500mm	18mm	10 m³ per hour	14m/min	8 hours	130x116x83cm	300 Kg	€ 6.350,00
Edward 700R**	4 Hp	380-400	50-60	700mm	25mm	15m³ per hour	20m/min	8 hours	130x116x83cm	400 Kg	€ 12.995,00

CHIPS series

TECHNICAL DATA

Model	Motor	Volt	Hertz	Cutter feed width	Cutter feed height	Cutting capacity of not pre-processed material	Cutting speed	Continuous run time	Dimensions (with legs kit) WxHxD	Weight	Price
Edward 300C***	3 Hp	220-240	50-60	300mm	14mm	4 m³ per hour	14m/min	8 hours	85x105x50cm	120 Kg	€ 4.950,00
Edward 300C***	3Hp	380-400	50-60	300mm	14mm	4 m³ per hour	14m/min	8 hours	85x105x50cm	120 Kg	€ 5.350,00
Edward 400C***	3 Hp	220-240	50-60	400mm	16mm	6 m³ per hour	14m/min	8 hours	90x105x50cm	130 Kg	€ 5.750,00
Edward 400C***	4Hp	380-400	50-60	400mm	16mm	6 m³ per hour	14m/min	8 hours	90x105x50cm	130 Kg	€ 5.950,00
Edward 500C**	4Hp	220-240	50-60	500mm	18mm	10 m³ per hour	14m/min	8 hours	130x116x83cm	300 Kg	€ 7.850,00
Edward 500C**	4Hp	380-400	50-60	500mm	18mm	10 m³ per hour	14m/min	8 hours	130x116x83cm	300 Kg	€ 7.850,00
Edward 700C**	4hp	380-400	50-60	700mm	25mm	15m³ per hour	20m/min	8 hours	130x116x83cm	400 Kg	€ 14.500,00

STRIPS series

TECHNICAL DATA

Model	Motor	Volt	Hertz	Cutter feed width	Cutter feed height	Cutting capacity of not pre-processed material	Cutting speed	Continuous run time	Dimensions (with legs kit) WxHxD	Weight	Price
Edward 300S*	3 Hp	220-240	50-60	300mm	14mm	4 m³ per hour	14m/min	8 hours	85x105x50cm	120 Kg	€ 3.950,00
Edward 300S*	3Hp	380-400	50-60	300mm	14mm	4 m³ per hour	14m/min	8 hours	85x105x50cm	120 Kg	€ 3.995,00
Edward 400S*	3 Hp	220-240	50-60	400mm	16mm	6 m³ per hour	14m/min	8 hours	90x105x50cm	130 Kg	€ 4.450,00
Edward 400S*	4Hp	380-400	50-60	400mm	16mm	6 m³ per hour	14m/min	8 hours	90x105x50cm	130 Kg	€ 4.750,00
Edward 500S**	4Hp	220-240	50-60	500mm	18mm	10 m³ per hour	14m/min	8 hours	130x116x83cm	300 Kg	€ 6.350,00
Edward 500S**	4Hp	380-400	50-60	500mm	18mm	10 m³ per hour	14m/min	8 hours	130x116x83cm	300 Kg	€ 6.350,00
Edward 700S**	4hp	380-400	50-60	700mm	25mm	15m³ per hour	20m/min	8 hours	130x116x83cm	400 Kg	€ 12.995,00

*Legs and wheels kit OPTIONAL for Edward 300 and 400 net and strips version € 445,00

** Legs kit INCLUDED. Wheels Kit OPTIONAL for Edward 500 and 700 € 336,00

*** Legs and wheels kit INCLUDED for Edward 300 and 400 chips version.

LEVIGATRICI

MONOSPAZZOLE

UTENSILI

SPECIALI

ASPIRATORI

CHIMICI

MARKETING

Serie500



Serie700



Edward Office

Document shredder

Edward Office has been designed to destroy huge quantity of documents and guarantee longlasting high performances.

Thanks to its wide cutter feed Edward Office allow to cut up to 30 A3 sheets of 80 grammes. An emergency stop lever to protect the user in case of accidental feeding of hairs, ties, scarves or other clothes.

Main Features:

- Wide cutting feed.
- Emergency stop lever.
- Shreds CD, credit cards, staples.
- Switch on/off and reverse.
- 100% Made in Italy

* HEPA13 vacuum Optional.



TECHNICAL DATA

Model	Motor	Volt	Hertz	Cutter feed width	Cutter feed height	Cutting speed	Cutting capacity	Weight	Price
Edward Office	1 Hp	230V or 110V	50 or 60	330mm	6mm	6m/min	30 pages 80gr. 297x420mm (A3)	45 Kg	€ 1.995,00

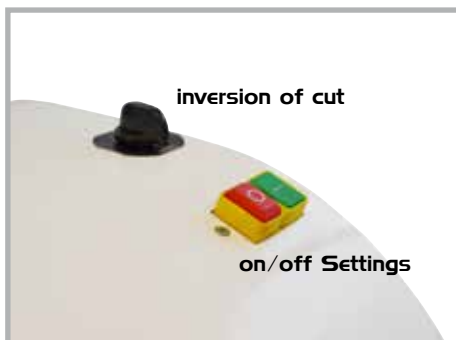

MARKETING SUPPORT

GRINDING
SINGLE DISC
TOOLS
SPECIAL
VACUUM
CHEMICALS
MARKETING

PICTURE	COD.	SIZE	€ each
---------	------	------	--------



KLINDEX CUP			
KLINCUPBY	Blue/Yellow		€ 10,00
KLINCUPG	Grey		€ 10,00



KLINDEX POLO			
Man	Woman		
100102	100106	S	€ 35,00
100103	100107	M	€ 35,00
100104	100108	L	€ 35,00
100105	100109	XL	€ 35,00



SUMMER & WINTER PANTS			
Summer	Winter		
100110	100110P	46	€ 48,00
100111	100111P	48	€ 48,00
100112	100112P	50	€ 48,00
100113	100113P	52	€ 48,00
100114	100114P	54	€ 48,00



T-SHIRT LEV.COLOR		
100143T	S	€ 14,50
100144T	M	€ 14,50
100145T	L	€ 14,50
100146T	XL	€ 14,50



T-SHIRT KLINDEX BLUE		
100151T	S	€ 14,50
100152T	M	€ 14,50
100153T	L	€ 14,50
100154T	XL	€ 14,50



KLINDEX SWEATSHIRT		
100123 - 100123B	M	€ 34,00
100124 - 100124B	L	€ 34,00
100125 - 100125B	XL	€ 34,00
100126 - 100126B	XXL	€ 34,00



KLINDEX JACKET		
100123G	M	€ 80,00
100124G	L	€ 80,00
100125G	XL	€ 80,00
100126G	XXL	€ 80,00

PICTURE	COD.	SIZE	€ each
---------	------	------	--------



GLOSSMETER		
GLOSSMETER		€ 860,00



SAFETY HELMET		
100126	53-63cm	€ 29,00



KLINDEX SHIRT		
IDA405XS	XS	€ 84,00
IDA405S	S	€ 84,00
IDA405M	M	€ 84,00
IDA405L	L	€ 84,00



T-SHIRT KLINDEX YELLOW		
100147T	S	€ 14,50
100148T	M	€ 14,50
100149T	L	€ 14,50
100150T	XL	€ 14,50



T-SHIRT LEV.BLACK		
100119T	S	€ 14,50
100120T	M	€ 14,50
100121T	L	€ 14,50
100122T	XL	€ 14,50



KLINDEX GILET		
100115	46	€ 43,00
100116	48	€ 43,00
100117	50	€ 43,00
100118	52	€ 43,00



TECHNICAL JACKET		
100123GT	M	€ 150,00
100124GT	L	€ 150,00
100125GT	XL	€ 150,00

PICTURE	COD.	SIZE	€ each
---------	------	------	--------



SPECIALIST STIKERS			
100158	50cm	free	
100159	25cm	free	



SHOPPER KLINDEX			
A4SHOP	35x44cm	€ 3,00	



KLINDEX BLOCK NOTES and PEN			
100155	A4	call	
100156	A5	call	
100157	black	€ 1,10	



FLAG KLINDEX			
Print on canvas nautical. Complete with carrying bag.			
ESPGOCC	1x3m	€ 320,00	



WINTER HAT KLINDEX			
10011001P	Hat	€ 11,00	

PICTURE	COD.	SIZE	€ each
---------	------	------	--------



KEY CHAIN			
100166	Key chain	€ 6,00	



KLINDEX COFFEE MUG			
100165		€ 10,00	



KLINDEX DVD VIDEO TRAINING			
- Marble			
- Granite			
- Gres			
- Superconcrete			
- Supershine			
dvd		free	



BADGE HOLDER			
100123	7cm	€ 4,00	



NECK WARMER			
KLINSC		€ 11,00	

KLINDEX LIGHT ROLLER and TOTEM



PICTURE	CODE	NAME	SIZE	€ each
---------	------	------	------	--------



POSTER LIGH ROLLER 80x200 cm				
100149LR	Bella Sander	80 x 200 cm	€ 180,00	
ROLLSC	Superconcrete	80 x 200 cm	€ 180,00	
100147LR	Floor Grinder	80 x 200 cm	€ 180,00	
100145LR	Supervak	80 x 200 cm	€ 180,00	
100143LR	Timba	80 x 200 cm	€ 180,00	
100144LR	Minitimba	80 x 200 cm	€ 180,00	
ESPOSITORE	Totem	170 cm	€ 190,00	

...and much more on www.klindex.com

MARKETING SUPPORT

GRINDING



SINGLE DISC



TOOLS

English Brochures

broch01ENG	Antike Floor	broch17ENG	Propane series
broch02ENG	Bella Stone	broch18ENG	Ready Cool & Quick Lock
broch03ENG	Edward	broch19ENG	Special Machines
broch04ENG	Elica	broch20ENG	Stone Soap
broch05ENG	Expander series	broch21ENG	Superclean
broch06ENG	Flash Diamond	broch22ENG	Superconcrete
broch07ENG	Hercules series	broch22ENG	Superconcrete tools
broch08ENG	King Conc	broch23ENG	Supershine
broch09ENG	Klindex wood	broch24ENG	Supervak
broch10ENG	Levighetor series	broch25ENG	Supervak Oil
broch11ENG	Maxi Orbit	broch26ENG	Supervak X series
broch12ENG	Maxi Quadra	broch27ENG	Triple K
broch13ENG	Mini Orbit	broch28ENG	Ufo
broch14ENG	MinTimba	broch29ENG	Waterfire
broch15ENG	Single Discs	broch30ENG	X-line
broch16ENG	Natural Stone tools	Cat18ENG	Product Catalogue 2018

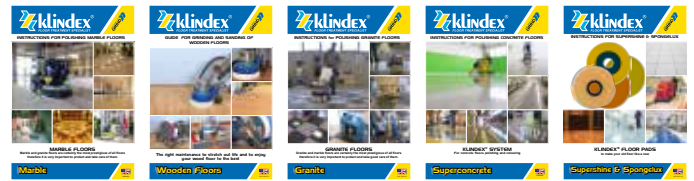

English Working guides

Guide01ENG	Superconcrete	A4	free
Guide02ENG	Marble	A4	free
Guide03ENG	Granite	A4	free
Guide04ENG	Wood	A4	free
Guide05ENG	Supershine & Spongelux	A4	free

SPECIAL

VACUUM

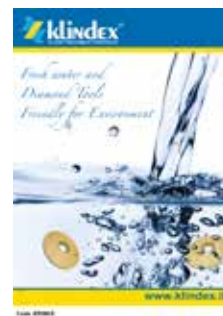
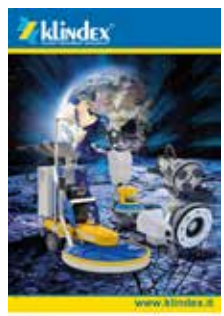

CHEMICALS

MARKETING

KLINDEX POSTER

100139	best Grinder	70x100cm	free
100140	Expander 1000	70x100cm	free
100141	Spice	70x100cm	free
100142	Gamma	70x100cm	free
100161	Evolution	70x100cm	free
100162	Spongelux H130cm	H 130cm	free
100163	Supershine	70x100cm	free
100164	Superconcrete	70x100cm	free



INTERNATIONAL CODE OF DIAMOND. The colour coding of the grit discs.

30	60	120	220	400	800	1800	3500

UNIT OF MEASURE

1" = 25,4mm

1 Libbre = 0,454 kg

1 Gallon = 3,78 Litri

R.P.M. = Rotazion/min

Pcs = Pieces

KLINDEX GRAFTS TOOLS

AS 100mm



AS 140mm



Butterfly



VT 100mm

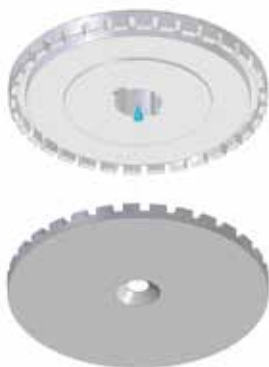

VT 140mm

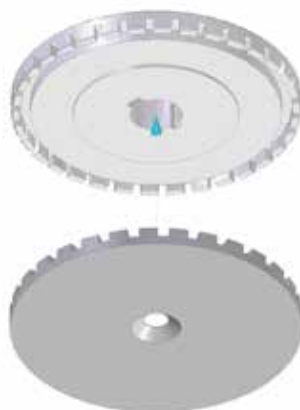

Quick Attack



GRINDING

SINGLE DISC

TOOLS

SPECIAL

VACUUM

CHEMICALS

MARKETING

GENERAL TERMS OF SALE

By placing the order the customer accepts without reserve the following conditions:

- 1) goods are delivered ex our warehouse in Manoppelo Italy.
- 2) upon customer's request for a deliver EX-WORK – FOB – CIF – C&F OR or other one to place of his choice, the cost of every deliveries will be invoiced to him.
- 3) Goods travel at consignee's risk even if under terms of sale free place of destination. Klindex packs shipments as carefully as possible. All claim for merchandise damaged in transit or for shortage of goods must be filled with the DELIVERING CARRIER. Klindex will not be responsible for any defects or statements of shortage of goods. Please check all cartons before you sign for the delivered goods.
- 4) Complaints for defects or statements of shortage of goods will be take into consideration within 8 days from receipt of goods, without prejudice to the disposition of point 3.
- 5) Payment must be absolutely carried out within the agreed terms.
- 6) The cost of packing will be invoiced at cost price.
- 7) Any dispute between the parties will be submitted to arbitration in Pescara Italy before the competent Court under its rules.
- 8) The characteristic of all machines showed in this catalogue are general and not binding for the factory. Klindex has the right to change any characteristic without any communications.
- 9) The following information must be always be specified in order: a) code and model b) exact electronically characteristics (in accordance with our available models).
- 10) RETURN GOODS POLICY. KLINDEX cannot accept returned items after 30 days from purchase. Any return made after 30 days will not be accepted and will be returned at expense of the customer – In addition, returned items that exhibit obvious misuse will be shipped back to the sender and no credit will be issued.
 - 10a) Non-stocking special order items are not returnable. Machines or other equipment with after market alteration that were not pre-approved by Klindex are not returnable.
 - 10b) Written consent must be obtained by Klindex prior to return. No returns will be accepted without a return authorization number.
 - 10c) Freight charges must be prepaid.
 - 10d) A 15 % restocking fee will be deducted from the credit note for any non defective returns.
 - 10e) Full credit will be allowed for Klindex's fault or if defects in material or in workmanship is the cause for the return.
- 11) CLAIM FOR DEFECTIVE MATERIAL
 - 11a) Defective goods must be returned and evaluated for approval before replacement occurs.
 - 11b) all claims must include an evaluation report to be filled on defective material.

11c) Klindex provides only those warranties identified in the printer literature that is distributed with the products. No other warranty effective unless it is signed only by Klindex.
 11d) Klindex disclaims any and all implied statutory warranty, including warranty without limitation, the warranty of merchantability and warranty of fitness for particular purpose not authorized.

11e) Klindex srl shall not be liable for any injury, loss or damage, direct, incidental or consequential, arising from of the miss use

for of the product. Before using, the user shall determinate the suitability of the product for the intended use and the user assumes all risk and liability whatsoever in connection therewith. 11f) the total liability of Klindex in any way related to the products sold hereunder, including liability for contract, breach or warranty, tort negligence, strict liability or otherwise, shall in no event exceed the amount of paid by the Buyer to the Seller. 11g) Klindex srl will not be liable for delay in shipping due to circumstances beyond the control of Klindex srl.

12) PRICING INFORMATION:

All pricing is subject to change without notice. Klindex will do its best to maintain catalogue prices throughout the year, but with the fluctuation in the foreign exchange rates, it may necessary for us to adjust price periodically throughout the year. This may lead to an increase or decrease in our list prices.

WARRANTY CONDITIONS

Liability for defects

1) KLINDEX srl ITALY shall by repair or replacement any defected in the Klindex machine resulting from fault design, materials or workmanship. Klindex is not liable for defects arising out of materials provided by or a design stipulated or specified by the purchaser.

2) The WARRANTY for machines equipped with "hours counter " is extended up to 2 years or 600 hours (the first expiring). To receive the extended warranty the customer only need to follow the service plan program performed by an authorized KLINDEX servicing assistance point. The first service has to be done within 500 hours or within 1 year.

The warranty for machine not equipped with "hours counter " is valid for 1 (one) year.

3) If the machine should cease to be in working order, the machine will be repaired or , according the KLINDEX estimation, the machine will be exchanged. The spare parts are either new or equivalent with new or repaired.

4) Defective parts which are replaced as stated above shall be placed at KLINDEX' s disposal and shall become KLINDEX' s property

Complaint.

5) A complaint shall be made within the warranty period. If any difficulties develop with the machine you should:

a) Contact KLINDEX CUSTOMER ASSISTANCE DEPARTMENT 65024 MANOPPELLO Via Tiburtina Km 209,200 Italia Tel +39 085 8596546 Fax +39 085 8599224 info@klindex.it

b) Return the product to the KLINDEX customer Assistance Service Point. Transportation charges from and to the Service Point or to our head office has to be prepaid by the purchaser. Valid warranty certification or other paper that confirm the date of the delivery machine shall be presented at the time for the compliant.

c) A complaint shall be made within the warranty period.

Limitation.

6) KLINDEX shall not be liable for any defects that are caused by circumstances that appear after the machine have been delivered and whilst it is in the possession of the purchaser.

The warranty is void if the purchaser hasn't followed the maintenance plan stipulated by the warranty certificate. If a maintenance plan is not stipulated by the warranty certificate the warranty is void if the time of goods have been used exceeds 500 hours.

The warranty doesn't include normal wear or perishable parts such as electrical cables, rubbers parts, hoses, brushes, capacitors and electronic parts.

7) KLINDEX' s liability does not cover defects which are caused by faulty maintenance, incorrect manoeuvre or faulty repair by the purchaser, or by alteration carried out without KLINDEX' s consent in writing. The same applies to any alterations of the machines or service performed by another party than KLINDEX or KLINDEX appointed distributor or KLINDEX approved service point.

The warranty is not applicable on defect that arises in connection with equipment or grinding tools that not can be assigned to KLINDEX' s original assortment.

There are not warranty which extend beyond this description. No warranties, including but not limited to warranty of merchantability, shall be implied. In case of a malfunction or defect, the producer is not responsible for any eventual uncompleted work by the customer or income loss.

8) Previous mentioned measures in p. 7 results in that the warranty from KLINDEX ceases to exist.

9) At complaint when no defect is found for which KLINDEX is liable, KLINDEX shall be entitled to compensation for the labour and costs which KLINDEX has incurred as result of the notice

10) If KLINDEX fails to fulfil its obligation within a reasonable time , the purchaser maybe by written notice require KLINDEX to do so within a final time. If KLINDEX fails to fulfil its obligation within that time, the purchaser may demand a reduction of the purchase price in proportion to the reduced value of the machine, provided that under no circumstances such reduction exceeds 15% of the purchase price. In the defect must be considered substantial, the purchaser may instead choose to terminate the contract

by written notice to KLINDEX , In case of termination the purchaser shell be entitled to compensation for the loss he has suffered. The compensation shall, however , not exceed 15 % of the purchase price.

11) Save as stipulated in clauses 1-5 KLINDEX shall not be liable for defects. This applies to any loss the defect may cause including cost of transportation, loss of production, loss of profit and any other economic cost. If KLINDEX has been guilty of gross negligence, the purchaser shall be entitled to compensation for the loss he has suffered. The total compensation shall, however not exceed the sales values on the machine.

12) Furthermore KLINDEX shall not be liable for delay caused by circumstance beyond the control of KLINDEX

13) There isn't any warranty for tools and/or for consumable. The operator must ensure that the tool selected is suitable for use that he needs. No responsibility can be attributed to KLINDEX for incorrect use of the tool or accessory.

Other:

14) The warranty certificate shall be considered as valid only if it is dated by KLINDEX or by KLINDEX appointed distributor and complete with the machine's type and serial number concerning the nature of the goods and their suitability for the use to which they will be put. Accordingly, all information on this Catalogue is supplied without any express warranty, condition or other term as to the quality of any specified goods, their suitability for any particular purpose or non-infringement of any intellectual property rights, and all implied warranties, conditions or terms of the same kind are hereby expressly excluded. KLINDEX will not under any circumstances be liable for any loss of income, profit, business, contracts or goodwill or any indirect or financial loss suffered by a party, whether arising in contact, negligence or otherwise. The information on this Catalogue may include technical inaccuracies or typographical errors. Information may be changed or updated without notice. KLINDEX may also make improvements and/or changes in the products described in this Catalogue without notice.



klindex®

Klindex s.r.l.
SS 5 Tiburtina Valeria km 209+200
Manoppello (PE) Italy
Tel +39 085 859 546
Fax +39 085 8599 224
www.klindex.com
info@klindex.com



Your Local Distributor:

